

OUR GENERAL CATALOGUE

**MODULAR SYSTEM  
WITH SIMPLICITY.**

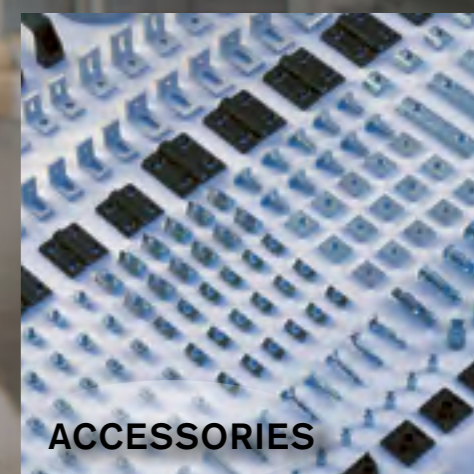

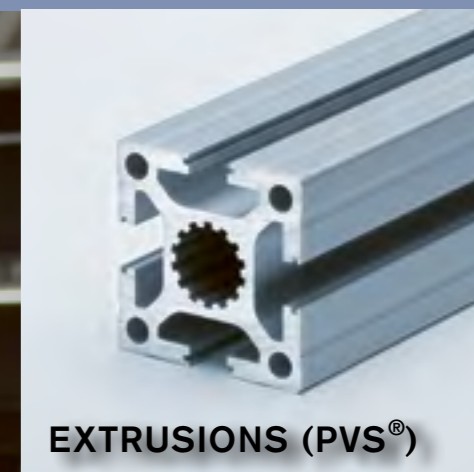

<b>About us</b>	<a href="#">3-4</a> Editorial services
	<a href="#">5-6</a> Products
	<a href="#">7-13</a> Applications

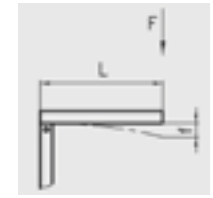

<b>Technical data</b>	<a href="#">15</a> Material data	<a href="#">23</a> Strength calculations
	<a href="#">16-22</a> Overview extrusions	<a href="#">24-26</a> Machining codes
	<a href="#">22</a> Tolerances	<a href="#">27</a> Machining extrusion

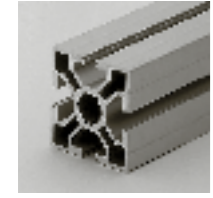

<b>Extrusion system base PVS®</b>	<a href="#">28-36</a> Base 50 extrusions	<a href="#">53-58</a> Base 30 extrusions
	<a href="#">37-43</a> Base 45 extrusions	<a href="#">59-60</a> Base 20 extrusions
	<a href="#">44-52</a> Base 40 extrusions	

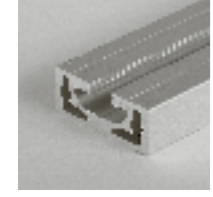

<b>Special extrusions</b>	<a href="#">61-66</a> Special extrusions
	<a href="#">67-68</a> Angle extrusions
	<a href="#">68-70</a> Diverse

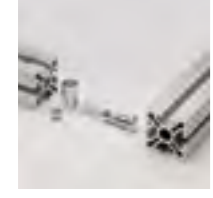

<b>Connection technology</b>	<a href="#">71-75</a> PVS® – the original	<a href="#">77</a> PVS® Direct
	<a href="#">75</a> PVS® connectors accessories	<a href="#">77</a> PVS®-Superlight
	<a href="#">76</a> Connection technology	<a href="#">78</a> Cable bridge, allen key

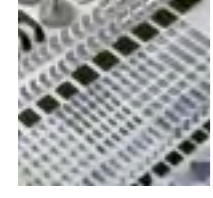

<b>Accessories</b>	<a href="#">80-81</a> Mounting brackets	<a href="#">84-85</a> Threaded inserts	<a href="#">92</a> Installation material	<a href="#">105-109</a> Handles, locks
	<a href="#">81</a> Clamping blocks	<a href="#">85-86</a> Levelling feet, base plates	<a href="#">94-96</a> Panels	<a href="#">109-110</a> Lock, switches, sealing plates
	<a href="#">82</a> Uniblocks, attachment bracket	<a href="#">86-87</a> Bolt-down brackets	<a href="#">96-101</a> Filler strips	<a href="#">110-116</a> Shafts, clamping blocks
	<a href="#">82-83</a> Threaded plates, extrusion nuts	<a href="#">88-90</a> Castors, rollers	<a href="#">102-104</a> Hinges, joints	<a href="#">117-119</a> Roller system, accessories



<b>Tube clamp system RVS®</b>	<a href="#">120</a> Technical data	<a href="#">127-129</a> Rectangular extrusion, aluminium tubes, accessories
	<a href="#">121-123</a> Clamp joints	
	<a href="#">124</a> Swivel clamp	<a href="#">130-131</a> Adjustable units
	<a href="#">125-126</a> Supports, slides	



<b>Service</b>	<a href="#">132</a> Our service
	<a href="#">133</a> Index
	<a href="#">134</a> Kanya distributors worldwide



#### Our service range

- ✓ range of articles ex stock
- ✓ extrusions cut to measure and processed
- ✓ consultation and engineering
- ✓ pre- or completely assembled
- ✓ external material procurement



Company video

## Aluminium extrusion system – modular with simplicity

Kanya AG is a leading global supplier of aluminium extrusion system and stands out due to its Swiss quality. Based on the Kanya aluminium extrusion system, we supply design solutions in the sectors of special-purpose engineering, automation and the machine manufacturing industry.

In our headquarters in Rüti ZH (Switzerland), over 50 employees work in the sectors of sales, engineering, production and assembly. The modern industrial building with an area of over 3500m<sup>2</sup> offers optimal requirements for efficient order processing. Globally, we work together with over 20 long-standing independent partners. Our international contractual partners have their own warehouses and the associated production infrastructure. This network means that Kanya profiles and components are available to all intents and purposes over the whole world.

# Milestones

**1974**

Kanya AG founded by Gertrud Rüegg



**1982**

Walter Bär participates in Kanya and manages the technical department.



**1997**

Opening celebration – new location in Rüti (Switzerland)



**2013**

Foundation of branch office Kanya China



**2016**

Extension of the factory building by 1'200 m<sup>2</sup> in Switzerland

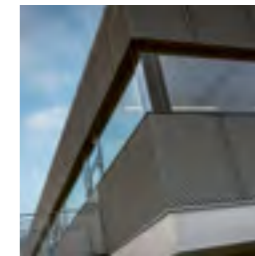

**1975**

Patenting of PVS® extrusion connection system

**1990**

Worldwide more than ten representatives

**2008**

Succession plan through Bachtel Group (Clemens Ruckstuhl and André Müller)

**2014**

Company anniversary – 40 years Kanya AG

**2021**

New lengthwise processing machine

# Our products

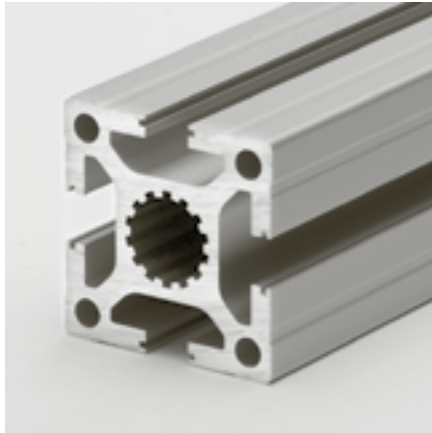

### Extrusion Connecting System PVS®

With the aluminum modular system, you will solve any construction task professionally, flexibly, durably and reliably. Our product range includes over 150 different profiles which are easily and safely connected with our connectors.

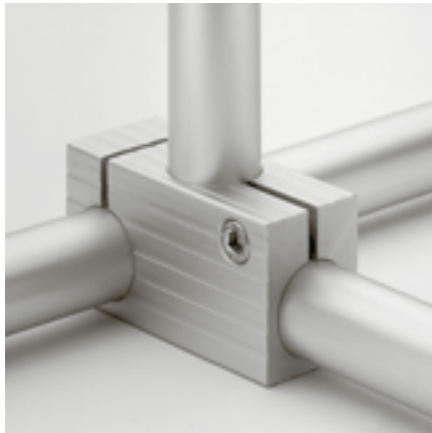

### Tube Clamp System RVS®

The Tube Clamp System provides creative and versatile solutions in response to a huge variety of requirements in the field of machine and apparatus construction. An optimal static is guaranteed thanks to the precise machined clamping elements.



### Accessories

The Kanya modular system allows an easy fixing of various accessories. The assortment of over 1'500 articles ranges from end caps, base connecting elements, panels up to angle extrusions and much more.

### 50 base extrusion

These extrusions are used wherever very high loads with small deflections must be supported.

### 45 base extrusion

Ideal complement to other extrusions with base 50, 40, 30 and 20.

### 40 base extrusion

The universal extrusion is extremely stable and has a good price-performance ratio.

### 30 base extrusion

Lightweight but stable extrusion for simple constructions and universal use.

### 20 base extrusion

Can be used for low load-bearing and filigree constructions.



Aluminium extrusion from A-Z

### Kanya system advantage

Due to the same nutdimension all different parts are compatible with each other.



# Product line

## Workplace systems

Kanya Ergoplace offers efficient, ergonomic and tailor-made solutions for workplaces in industry and business. The range includes tables with height-adjustable lifting columns, lights, brackets, shelves, base units and much more. Based on the Ergoplace checklist we will be happy to find out your needs.



## Machining doors

Kanya Safe is a modular system solution for safety doors and protective enclosures. Numerous solutions can be implemented in a wide range of applications with the flexible modules and components. Kanya Safe offers the right solution for every requirement, regardless of whether it is for a machine housing, a double lifting-door or a multi-part safety door. The system solution can be altered or modified at any time to meet the requirements.



## KLINK®

The Kanya Klink system makes it even easier to keep things in order, maintain an overview thus increase productivity. The Klink system consists of shelves of different sizes, a suspension extrusion and suspension rails which can be easily hooked into the workstation. This reaches finally an end to the search for tools.

## More information



### Kanya Ergoplace – Overview

Workplace systems for better ergonomics (6-page leaflet)



### Kanya Ergoplace – General brochure

General brochure about workplace systems with checklist (40-page brochure)

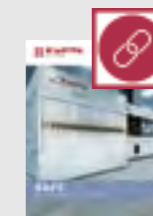

### Kanya Safe

Modular safety doors and protective enclosures

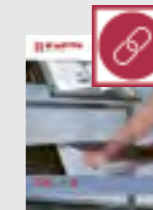

### Kanya Klink

The suspension console for maximum flexibility

Please order the brochures on our website or download the requested brochure as PDF.  
[www.kanya.com/service](http://www.kanya.com/service)



Machine base frame and housing



Workplace systems



Operating material



Machining door



Automation and conveyor technology



Protective cabinet and noise protection

**You have ideas.  
We have the solution.**

## Machine base frame and housing

Today, machine claddings do not just fulfil the task of protecting persons, but rather they are an integral part of the machine with a high demand on design. For a high-quality cladding that is tailored to the machine, the versatility of the Kanya aluminium profile modular constructions present the ideal prerequisites.

The standard anodised profiles can also be powder-coated to the desired colours. In combination with a wide variety of surface elements such as acrylic glass, wood and metal, the opportunity presents itself for setting the emphasis on integrating the machine in a sophisticated overall appearance.

### Kanya system benefits

- ✓ high protective function such as safety, noise and sound protection
- ✓ sophisticated overall appearance (design)
- ✓ according to the machinery directives



## Solutions



### Machine housing

Plastic parts processing after injection moulding process

Properties:

- protected region
- several opening ranges
- robust design and stability

### Machine top

Injection moulding machine for PET manufacture.

Properties:

- dust protection
- sliding frames



### Machine base frame

Transport and production module in the circuit boards industry

Properties:

- rigid rack structure
- attractive design
- modular construction



## Workplace systems

The labor law requires an ergonomic design of workplaces. Optimised work processes and a corresponding infrastructure improve productivity. The ergonomic aspect is an important component of a workplace. Heightadjustable workbenches, optimal bench dimensions, lighting and individual tool positioning are just a few examples of a direct or indirect impact on the health, motivation and performance of the employees.

Kanya Ergoplace satisfies all conditions for an ergonomically oriented workplace system. Workplace systems are easy to assemble, are based on a modular design and can be extended flexibly.

### Kanya system benefits

- ✓ customized solution
- ✓ ergonomically optimized
- ✓ modular, flexible and simple installation
- ✓ «Industry 4.0» solution



Workplace systems Ergoplace



## Solutions

### Packaging workplace in the logistics

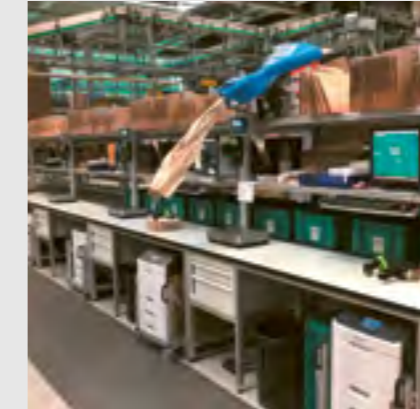

Properties:

- height-adjustable desks and workbenches
- optimal desk dimensions
- individual storage shelves

### Assembly workstation in the production area

Properties

- height-adjustable desks and workbenches
- individual tool positioning
- lighting depending on the work process



### Interlinked workplace (assembly and production line)

Properties:

- simple to complex solutions
- modular and flexible



## Operating material

Whether it be tool trolleys, medicine trolleys or a vehicle construction for a pick-up. Tailor-made solutions can be constructed using the Kanya profile connection system (PVS). Our engineering team has many years of experience in applications with the Kanya aluminium profile modular construction system.

We are equipped with the most modern IT systems with which we formulate solutions for you and set up the required list of items. Use our know-how and tell us your construction ideas.

### Kanya system benefits

- ✓ tailor-made solution
- ✓ modular and flexible
- ✓ simple installation

## Solutions



### Operating tool trolley

Properties:

- light base frame
- multifunctional mounting options
- easy to extend at any time

### Workshop trolleys

Properties:

- lower cabinet integrated as a trolley
- light frame



### Medicine trolley

Properties:

- robust design and stability
- personalised access with RFID chip
- simple cleaning of the material
- good running characteristics of the rollers



# Machining door

Machine doors safely separate the work area between human and machine. But also the opening and closing times, which directly influence the increase in productivity, are also relevant to the safety aspects.

Kanya Safe is a modular system solution for safety doors and protective enclosures. Numerous solutions can be implemented in a wide range of applications with the flexible modules and components. Kanya Safe offers the right solution for every requirement, regardless of whether it is for a machine housing, a double lifting-door or a multi-part safety door. The system solution can be altered or modified at any time to meet the requirements and thus represents a sustainable investment.

**Kanya system benefits**

- ✓ simple, ready-to-install solution with drop guard
- ✓ robust construction and thin construction depth
- ✓ extremely compact design
- ✓ CE compliant (EC declaration of conformity)



Brochure Door solutions



# Solutions



## Double lifting-door

- Properties:
- high opening speed
  - minimal effort when opening and closing
  - laser resistant, resistant against contamination due to Kanya sliding guides
  - integrated protective machine door control system double-lifting door

## Machine safety door

- Properties:
- free access for loading and unloading
  - double lifting-door



## Laser protection lift door

- Properties:
- ready-to-install solution
  - robust construction
  - laser protection class 4

## Automation and conveyor technology

In the manufacturing processes of today, economic flexibility is in particular demand. A wide variety of construction parts are assembled, processed or measured at increasingly shorter intervals on specially manufactured clamping and mounting devices.

The Kanya profile system ensures that the layout of the devices does not become a disproportional cost factor. The versatility and modularity of the modular construction system enables the widest variety of requirements to be cost-effectively and readily adapted.

### Kanya system benefits

- ✓ simple, ready-to-install solution
- ✓ robust construction and thin construction depth
- ✓ easy mounting of sensors and adapters
- ✓ flexible adjustments can be made later



## Solutions



### Table conveyor system with chain conveyor

Properties:

- tight bends save storage space
- easy to assemble

### Conveyor system for an assembly system for automobile axles

Properties:

- load capacities up to 400 kg/cassette
- freely configurable
- low-noise
- robust and durable



### Conveyor system for automation of a processing machine

Properties:

- high modularity for complex layouts
- used for loading and unloading of processing machines
- robust and durable



# Protective cabinet and noise protection

The effects of noise pollution at the workplace on concentration, performance and motivation as well as the well-being of the employees must not be underestimated. If the permissible threshold limits are continuously exceeded, sustained noise leads to health damage. For this reason, the Occupational Safety Act specifies very clear reference values that protect health and safety.

### Kanya system benefits

- ✓ individual noise protection systems prevent health damage
- ✓ comply with the employment law (EU: Occupational Safety Act)
- ✓ protection against mechanical damage



## Solutions



### Protection cabin

Low-pressure cabin for the manufacture of power storage modules

Properties:

- extremely airtight construction
- ESD construction
- accessibility through large sliding doors

### Noise protection

Noise protection cladding for winding machine electric motors

Properties:

- noise level reduction
- unhindered access through the door front with special noise protection glazing



### Noise protection

Noise protection airlock for endurance test system of angles grinders

Properties:

- noise level reduction of 28 dB(A)
- total access to the test room
- unhindered access through the door front with special noise protection glazing

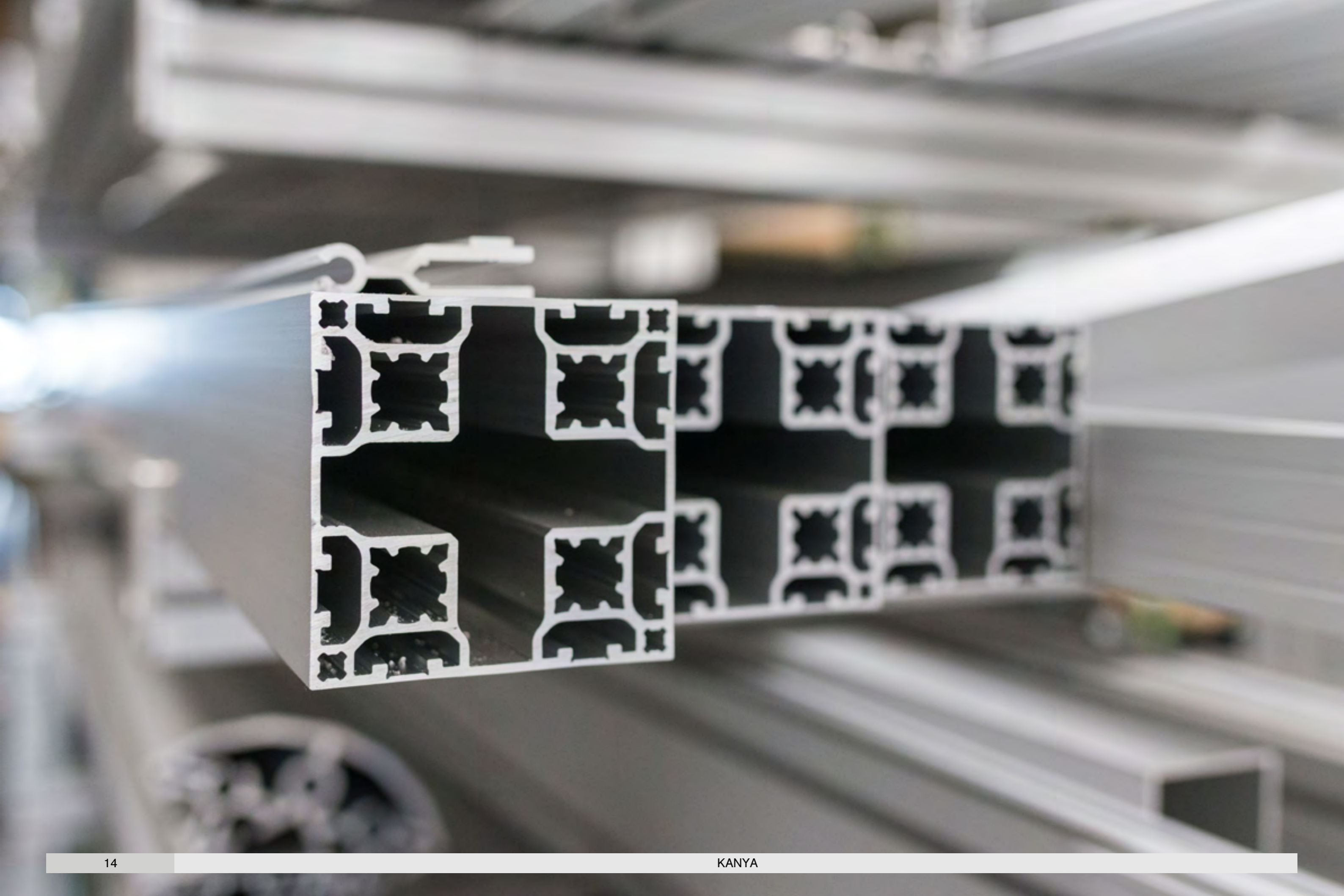

Material data

Material data of aluminium extrusions













Alloy	EN AW-6063	
Quality	T66	Temper-hardened (F25)
Tolerances	DIN EN 12020-2	
Density/weight	$\delta$ : 2.7 g/cm <sup>3</sup>	
Tensile strength	R <sub>m</sub> : min 245 N/mm <sup>2</sup>	
Yield	R <sub>p 0.2</sub> : min 200 N/mm <sup>2</sup>	
Elongation	A <sub>5</sub> : min 8%	
	A <sub>10</sub> : min 6%	
Module of elasticity	E: 70 KN/mm <sup>2</sup>	
Brinell hardness	HB ~80	
Surface	E6/EV1 (anodised, aluminium coloured) Layer thickness 10 $\mu$	Colour anodised or powder coated on request in accordance with the RAL table, raw
Thermal expansion	0.0232 mm/m/° $\Delta$ t	





Alloy	EN AW-6060	
Quality	T66	Temper-hardened (F22)
Tolerances	DIN EN 12020-2	
Density/weight	$\delta$ : 2.7 g/cm <sup>3</sup>	
Tensile strength	R <sub>m</sub> : min 215 N/mm <sup>2</sup>	
Yield	R <sub>p 0.2</sub> : min 160 N/mm <sup>2</sup>	
Elongation	A <sub>5</sub> : min 8%	
	A <sub>10</sub> : min 6%	
Module of elasticity	E: 70 KN/mm <sup>2</sup>	
Brinell hardness	HB ~75	
Surface	E6/EV1 (anodised, aluminium coloured) Layer thickness 10 $\mu$	Colour anodised or powder coated on request in accordance with the RAL table, raw
Thermal expansion	0.0232 mm/m/° $\Delta$ t	



Technical data

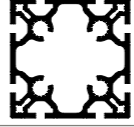
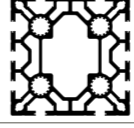
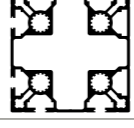

50 mm base extrusion	Type		Alloy	Weight [kg/m]	I <sub>x,y</sub> [cm <sup>4</sup> ]	W <sub>x,y</sub> [cm <sup>2</sup> ]	Page
Four sided softline extrusion 50x50	Type A10-0		EN AW-6060	2.4	22.1	8.22	<a href="#">28</a>
Lightweight extrusion 50x50	Type A02-1		EN AW-6063	1.8	16.07	6.42	<a href="#">28</a>
Base extrusion 50x50	Type A01-1		EN AW-6063	2.3	20.88	8.35	<a href="#">29</a>
Heavy duty extrusion 50x50	Type MA1-1		EN AW-6063	3.1	29.37	11.75	<a href="#">29</a>
Face extrusion 50x50	Type A01-8		EN AW-6063	2.2	20.38, 19.61	8.15, 7.55	<a href="#">29</a>
Corner extrusion 50x50	Type A01-7		EN AW-6060	2.0	17.7	7.05	<a href="#">29</a>
Double face extrusion 50x50	Type A02-4		EN AW-6063	2.0	19.59, 18.17	7.83, 7.27	<a href="#">30</a>
Angle extrusion 50x45°	Type A02-8		EN AW-6063	1.7	13.10	4.50	<a href="#">30</a>
Face panel extrusion 50x50	Type A03-8		EN AW-6060	2.2	20.40, 19.72	8.07, 7.89	<a href="#">30</a>
Lightweight extrusion 50x100	Type A02-2		EN AW-6063	3.8	148.15, 37.15	29.63, 15.00	<a href="#">31</a>
Base extrusion 50x100	Type A01-2		EN AW-6063	4.6	149.84, 41.25	29.97, 16.50	<a href="#">31</a>
Heavy duty extrusion 50x100	Type MA1-2		EN AW-6063	5.3	198.66, 50.28	39.73, 20.11	<a href="#">32</a>

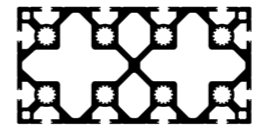
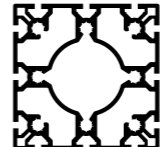
50 mm base extrusion	Type		Alloy	Weight [kg/m]	I <sub>x,y</sub> [cm <sup>4</sup> ]	W <sub>x,y</sub> [cm <sup>2</sup> ]	Page
Face extrusion 50x100	Type MA1-4		EN AW-6063	5.2	203.67, 54.31	40.73, 21.03	<a href="#">32</a>
Radius extrusion 100x100	Type A03-9		EN AW-6063	3.2	100.00	20.00	<a href="#">33</a>
Base extrusion 100x100	Type MA3-5		EN AW-6063	7.3	330.90	66.018	<a href="#">33</a>
Heavy duty extrusion 100x100	Type MA1-5		EN AW-6063	8.9	363, 345	76, 73	<a href="#">34</a>
Corner extrusion 100x100	Type A03-7		EN AW-6063	7.1	314.10	62.82	<a href="#">34</a>
Beam extrusion 50x150	Type MA1-3		EN AW-6063	7.0	599.8, 71.9	81.11, 29.42	<a href="#">35</a>
Beam extrusion 50x200	Type MA1-6		EN AW-6063	8.8	1315.83, 92.71	131.58, 37.08	<a href="#">35</a>
Heavy duty extrusion 100x200	Type MA1-9		EN AW-6063	16.4	2435.3, 705.6	243.53, 141.12	<a href="#">36</a>
Base extrusion 150x150	Type MA1-8		EN AW-6063	13.3	1264.46	168.59	<a href="#">36</a>



45 mm base extrusion













45 mm base extrusion	Type	Alloy	Weight [kg/m]	I <sub>x,y</sub> [cm <sup>4</sup> ]	W <sub>x,y</sub> [cm <sup>3</sup> ]	Page
Four sided softline extrusion 45x45	Type E10-1	EN AW-6063	2.1	14.07	6.25	<a href="#">37</a>
Light extrusion 45x45	Type E02-1	EN AW-6063	1.7	13.16	5.85	<a href="#">37</a>
Base extrusion 45x45	Type E01-1	EN AW-6063	2.1	16.12	7.16	<a href="#">37</a>
Face extrusion 45x45	Type E02-6	EN AW-6063	1.6	11.76, 12.20	5.13, 5.42	<a href="#">37</a>
Corner extrusion 45x45	Type E02-7	EN AW-6063	1.5	11.75, 11.83	5.12, 5.16	<a href="#">38</a>
Double face extrusion 45x45	Type E02-4	EN AW-6063	1.6	11.46, 12.33	5.09, 5.48	<a href="#">38</a>
Softline extrusion 45x45	Type E03-1	EN AW-6063	1.5	9.70	3.80	<a href="#">38</a>
Light extrusion 45x90	Type E02-3	EN AW-6063	2.8	90.44, 23.62	20.10, 10.50	<a href="#">39</a>
Base extrusion 45x90	Type E01-3	EN AW-6063	3.5	109.54, 29.77	24.34, 13.23	<a href="#">39</a>
Face extrusion 45x90	Type E01-14	EN AW-6063	3.5	109.45, 30.23	24.32, 13.38	<a href="#">40</a>
Corner extrusion 45x90	Type E02-2	EN AW-6063	2.7	82.76, 22.31	18.26, 9.79	<a href="#">40</a>
Beam extrusion 45x135	Type E01-19	EN AW-6063	4.9	334.22, 43.41	49.51, 19.30	<a href="#">41</a>









45 mm base extrusion / 40 mm base extrusion

45 mm base extrusion	Type	Alloy	Weight [kg/m]	I <sub>x,y</sub> [cm <sup>4</sup> ]	W <sub>x,y</sub> [cm <sup>3</sup> ]	Page
Beam extrusion 45x180	Type E01-16	EN AW-6063	6.4	743.74, 57.06	82.64, 25.36	<a href="#">41</a>
Light extrusion 90x90	Type E02-5	EN AW-6063	4.7	160.09	35.58	<a href="#">42</a>
Base extrusion 90x90	Type E01-4	EN AW-6063	6.1	205.78	45.73	<a href="#">42</a>
Beam extrusion 90x135	Type E01-13	EN AW-6063	8.1	618.00, 300.57	98.56, 66.79	<a href="#">43</a>
Beam extrusion 90x180	Type E01-5	EN AW-6063	12.1	1525.63, 443.9	169.51, 98.64	<a href="#">43</a>

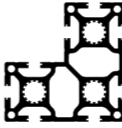
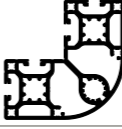
40 mm base extrusion	Type	Alloy	Weight [kg/m]	I <sub>x,y</sub> [cm <sup>4</sup> ]	W <sub>x,y</sub> [cm <sup>3</sup> ]	Page
Four sided softline extrusion 40x40	Type C10-0	EN AW-6060	1.6	9.6	4.75	<a href="#">44</a>
Four sided softline extrusion 40x80	Type C10-3	EN AW-6060	2.8	69.73, 18.52	17.43, 9.26	<a href="#">44</a>
Four sided softline extrusion 80x80	Type C10-4	EN AW-6060	4.4	119.40	29.85	<a href="#">44</a>
Super lightweight extrusion 40x40	Type C03-1	EN AW-6060	1.3	8.20	4.10	<a href="#">45</a>
Lightweight extrusion 40x40	Type C02-1	EN AW-6063	1.5	9.35	4.67	<a href="#">45</a>

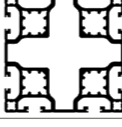







40 mm base extrusion	Type		Alloy	Weight [kg/m]	I <sub>x,y</sub> [cm <sup>4</sup> ]	W <sub>x,y</sub> [cm <sup>2</sup> ]	Page
Base extrusion 40x40	Type C01-1		EN AW-6063	2.0	11.70	5.75	<a href="#">45</a>
Face extrusion 40x40	Type C01-8		EN AW-6063	2.0	11.66, 11.67	5.78, 5.83	<a href="#">45</a>
Corner extrusion 40x40	Type C01-7		EN AW-6063	1.5	9.21	4.53	<a href="#">46</a>
Double face extrusion 40x40	Type C02-4		EN AW-6063	1.5	9.56, 9.21	4.78, 4.60	<a href="#">46</a>
Face panel extrusion 40x40	Type C04-2		EN AW-6063	1.6	9.13, 9.92	4.57, 4.96	<a href="#">46</a>
Corner panel extrusion 40x40	Type C04-7		EN AW-6063	1.6	9.53	4.76	<a href="#">46</a>
45° angle extrusion	Type C04-4		EN AW-6060	1.5	8.46, 9.11	3.01, 3.44	<a href="#">47</a>
40x45° angle extrusion	Type C02-8		EN AW-6063	1.2	6.30	2.70	<a href="#">47</a>
Softline extrusion 40x40	Type C03-8		EN AW-6060	1.3	6.70	2.97	<a href="#">47</a>
Light extrusion 40x80	Type C02-3		EN AW-6063	2.8	64.90, 17.70	16.23, 8.85	<a href="#">48</a>
Base extrusion 40x80	Type C01-3		EN AW-6063	3.7	81.95, 22.74	20.49, 11.37	<a href="#">48</a>
Face extrusion 40x80	Type C01-5		EN AW-6063	2.6	64.40, 17.20	16.10, 8.60	<a href="#">48</a>

40 mm base extrusion	Type		Alloy	Weight [kg/m]	I <sub>x,y</sub> [cm <sup>4</sup> ]	W <sub>x,y</sub> [cm <sup>2</sup> ]	Page
Light extrusion 40x120	Type C03-9		EN AW-6060	4.0	203.49, 25.75	33.91, 12.87	<a href="#">48</a>
Beam extrusion 40x120	Type C01-9		EN AW-6063	5.36	263.2, 33.94	43.09, 16.72	<a href="#">49</a>
Beam extrusion 40x160	Type C02-9		EN AW-6063	7.0	602.2, 45	74.09, 22.18	<a href="#">49</a>
L-shaped extrusion 80x80x40	Type C01-6		EN AW-6063	5.0	108.05	23.56	<a href="#">50</a>
Corner extrusion 80x80x40 round	Type C03-6		EN AW-6060	3.6	76.40	19.10	<a href="#">50</a>
Base extrusion 80x80	Type C01-4		EN AW-6063	6.0	154.70	38.68	<a href="#">51</a>
Lightweight extrusion 80x80	Type C03-4		EN AW-6063	4.4	115.66	28.92	<a href="#">51</a>
Corner extrusion 80x80	Type C03-7		EN AW-6060	4.5	117.70	29.43	<a href="#">51</a>
Beam extrusion 80x120	Type MC1-2		EN AW-6063	8.4	451.20, 219.76	75.20, 54.94	<a href="#">52</a>
Heavy duty extrusion 80x160	Type MC1-9		EN AW-6063	11.0	1018.98, 296.53	112.37, 74.13	<a href="#">52</a>

30 mm base extrusion	Type	Alloy	Weight [kg/m]	I <sub>x,y</sub> [cm <sup>4</sup> ]	W <sub>x,y</sub> [cm <sup>3</sup> ]	Page
Four sided softline extrusion 30x30	Type B10-0	EN AW-6060	1.0	3.30	2.20	<a href="#">53</a>
Super lightweight extrusion 30x30	Type B03-1	EN AW-6060	0.7	2.63	1.76	<a href="#">53</a>
Lightweight extrusion 30x30	Type B02-1	EN AW-6063	0.9	2.95	1.97	<a href="#">53</a>
Heavy duty extrusion 30x30	Type MB1-1	EN AW-6063	1.1	3.82	2.54	<a href="#">53</a>
Face extrusion 30x30	Type B03-2	EN AW-6063	0.8	2.85, 2.83	1.90, 1.83	<a href="#">54</a>
Face extrusion with panel slots 30x30	Type B02-2	EN AW-6063	0.9	2.93, 2.76	1.93, 1.84	<a href="#">54</a>
Corner extrusion 30x30	Type B02-3	EN AW-6063	0.8	2.70	1.75	<a href="#">54</a>
Corner panel extrusion 30x30	Type B01-3	EN AW-6063	0.8	2.70	1.75	<a href="#">54</a>
Double face extrusion 30x30	Type B02-4	EN AW-6063	0.8	2.73, 2.74	1.82, 1.83	<a href="#">55</a>
Softline extrusion 30x30	Type B01-8	EN AW-6060	0.7	2.16	1.44	<a href="#">55</a>
Angle extrusion 30°	Type B04-3	EN AW-6060	0.9	3.23, 2.89	1.54, 1.48	<a href="#">55</a>
Angle extrusion 45°	Type B04-4	EN AW-6060	0.9	3.14, 2.91	1.44, 1.45	<a href="#">55</a>

30 mm base extrusion	Type	Alloy	Weight [kg/m]	I <sub>x,y</sub> [cm <sup>4</sup> ]	W <sub>x,y</sub> [cm <sup>3</sup> ]	Page
Angle extrusion 60°	Type B04-6	EN AW-6060	0.9	3.07, 2.94	1.45, 1.51	<a href="#">56</a>
Base extrusion 30x50	Type B01-9	EN AW-6063	1.2	10.94, 4.33	4.38, 2.90	<a href="#">56</a>
Face extrusion with panel slots 30x50	Type MB1-9	EN AW-6063	1.3	11.25, 4.84	4.50, 3.23	<a href="#">56</a>
Face extrusion 30x50	Type MB2-9	EN AW-6063	1.3	11.30, 4.55	4.52, 3.03	<a href="#">56</a>
Base extrusion 30x60	Type B01-6	EN AW-6063	1.5	20.52, 5.20	6.84, 3.47	<a href="#">57</a>
Face extrusion with panel slots 30x60	Type B03-6	EN AW-6060	1.5	19.33, 5.43	6.44, 3.60	<a href="#">57</a>
Corner extrusion 30x60	Type B02-5	EN AW-6063	1.6	21.73, 5.92	7.24, 3.95	<a href="#">57</a>
Base extrusion 60x60	Type B02-6	EN AW-6063	2.4	35.83	11.94	<a href="#">57</a>
Base extrusion 30x100	Type MB1-2	EN AW-6060	2.3	80.77, 8.95	16.15, 5.97	<a href="#">58</a>
Face extrusion with panel slots 30x100	Type B01-2	EN AW-6060	2.1	77.86, 8.79	15.57, 5.72	<a href="#">58</a>
Face extrusion 30x300	Type B03-3	EN AW-6063	5.1	1755.64, 26.06	117.04, 17.30	<a href="#">58</a>
Tube extrusion ø30	Type R03-98	EN AW-6063	0.6	13.13	8.75	<a href="#">58</a>

## 20 mm base extrusion

20 mm base extrusion	Type		Alloy	Weight [kg/m]	I <sub>x,y</sub> [cm <sup>4</sup> ]	W <sub>x,y</sub> [cm <sup>3</sup> ]	Page
Base extrusion 20x20	Type D01-5		EN AW-6060	0.4	0.60	0.60	<a href="#">59</a>
Corner extrusion 20x20	Type D01-3		EN AW-6063	0.4	0.65	0.65	<a href="#">59</a>
Face extrusion 20x20	Type D01-8		EN AW-6060	0.4	0.68, 0.59	0.68, 0.59	<a href="#">59</a>
Softline extrusion 20x20	Type D03-8		EN AW-6060	0.4	0.47	0.47	<a href="#">59</a>
Base extrusion 20x40	Type D01-7		EN AW-6060	0.7	3.91, 1.10	1.95, 1.10	<a href="#">59</a>
Face extrusion 20x40	Type D02-8		EN AW-6060	0.8	4.15, 1.26	2.07, 1.18	<a href="#">59</a>
Face extrusion 20x50	Type D02-5		EN AW-6063	0.9	7.71, 1.58	3.08, 1.58	<a href="#">60</a>
Face extrusion 20x100	Type D02-1		EN AW-6063	1.6	55.5, 3.01	11.1, 3.01	<a href="#">60</a>

## Special extrusions

Special extrusions	Type		Alloy	Weight [kg/m]	I <sub>x,y</sub> [cm <sup>4</sup> ]	W <sub>x,y</sub> [cm <sup>3</sup> ]	Page
Wall rail 18x50	Type A19-9		EN AW-6063	0.9	-	-	<a href="#">61</a>
Slot extrusion 16x40	Type C08-1		EN AW-6063	1.0	-	-	<a href="#">61</a>
Slot extrusion 16x40	Type B19-4		EN AW-6063	0.66	-	-	<a href="#">61</a>
Wall rail 20x120	Type C08-4		EN AW-6063	2.1	-	-	<a href="#">61</a>
Slot extrusion 20x80	Type C08-2		EN AW-6063	2.4	54.49, 3.97	13.62, 3.97	<a href="#">62</a>
Slot extrusion 20x120	Type C08-3		EN AW-6063	4.4	177.95, 6.31	29.66, 6.31	<a href="#">62</a>
Triple channel extrusion 30x15	Type B05-1		EN AW-6060	0.3	-	-	<a href="#">62</a>
3-fold roller guide	Type B06-3		EN AW-6060	0.30	-	-	<a href="#">63</a>
Glass rail 5 mm	Type B06-4		EN AW-6060	0.25	-	-	<a href="#">63</a>
19° auxiliary extrusion	Type A05-2		EN AW-6060	0.5	-	-	<a href="#">63</a>
19° auxiliary extrusion	Type B05-2		EN AW-6060	0.4	-	-	<a href="#">63</a>
Box frame extrusion 30x95	Type B01-7		EN AW-6060	1.8	55.99, 7.94	11.79, 5.29	<a href="#">64</a>

Special extrusions	Type	Alloy	Weight [kg/m]	I <sub>x,y</sub> [cm <sup>4</sup> ]	W <sub>x,y</sub> [cm <sup>3</sup> ]	Page
Runner extrusion 30x50	Type B10-9	EN AW-6063	1.1	9.17, 4.51	3.37, 2.98	<a href="#">64</a>
Frame extrusion 30x15	Type B15-1	EN AW-6063	0.7	1.4, 0.71	0.933, 0.473	<a href="#">64</a>
30 mm base octagonal extrusion	Type B15-3	EN AW-6063	2.7	50.5	14.02	<a href="#">64</a>
Double clamping extrusion 16x50	Type A05-7	EN AW-6063	0.46	-	-	<a href="#">65</a>
Panel clamp extrusions 13.5x50	Type A05-8	EN AW-6060	0.3	-	-	<a href="#">65</a>
Panel clamp extrusions 13.6x40	Type C05-8	EN AW-6060	0.3	-	-	<a href="#">65</a>
U-clamping extrusion 8x13.5	Type B19-6	EN AW-6060	0.1	-	-	<a href="#">65</a>
Suspension extrusion base 30/50	Type S91-013 Type S91-014	EN AW-6063	0.14	-	-	<a href="#">65</a>
Support extrusion 11x30.5	Type B19-7	EN AW-6060	0.4	-	-	<a href="#">66</a>
Aluminium guide extrusion	Type B19-8	EN AW-6060	0.2	-	-	<a href="#">66</a>
Support extrusion 25x25	Type B05-5	EN AW-6060	0.48	-	-	<a href="#">66</a>
Frame extrusion 27x30	Type B05-6	EN AW-6060	0.79	-	-	<a href="#">66</a>

Special extrusions	Type	Alloy	Weight [kg/m]	I <sub>x,y</sub> [cm <sup>4</sup> ]	W <sub>x,y</sub> [cm <sup>3</sup> ]	Page
Angle extrusion 38x38	Type A30-0	EN AW-6060	1.5	-	-	<a href="#">67</a>
Angle extrusion 31x31	Type C30-0	EN AW-6060	0.9	-	-	<a href="#">67</a>
Angle extrusion 60x60	Type A30-2	EN AW-6060	2.8	-	-	<a href="#">67</a>
Angle extrusion 70x70	Type C30-3	EN AW-6060	2.5	-	-	<a href="#">67</a>
Angle extrusion 85x85	Type E30-3	EN AW-6060	3.7	-	-	<a href="#">67</a>
Angle extrusion 100x100	Type A30-4	EN AW-6060	6.38	-	-	<a href="#">67</a>
Angle extrusion 60x120	Type A47-0	EN AW-6060	4.6	-	-	<a href="#">68</a>
Angle extrusion 25x35	Type A30-5	EN AW-6060	0.7	-	-	<a href="#">68</a>
Hinge extrusion 54x17	Type A60-6	EN AW-6060	1.3	-	-	<a href="#">68</a>
Hinge extrusion 44x17	Type C60-6	EN AW-6060	1.1	-	-	<a href="#">68</a>
Hinge extrusion 57.5x8	Type A60-1	EN AW-6063	1.3	-	-	<a href="#">68</a>
Hinge extrusion 47.5x8	Type B60-1	EN AW-6063	1.1	-	-	<a href="#">68</a>

Special extrusions	Type	Alloy	Weight [kg/m]	$I_{x,y}$ [cm <sup>4</sup> ]	$W_{x,y}$ [cm <sup>3</sup> ]	Page
Hinge extrusion 47x4	Type A60-2	EN AW-6060	0.5	-	-	68
Hinge extrusion 37x4	Type B60-2	EN AW-6060	0.4	-	-	68
Hinge extrusion 36.5x20	Type A60-5	EN AW-6063	1.2	-	-	68
Handle strip extrusion 30x35	Type B65-6	EN AW-6063	0.6	-	-	69
Base 50 block extrusion	Type A34-0	EN AW-6060	1.6	-	-	69
Base 40 block extrusion	Type C34-0	EN AW-6060	1.3	-	-	69
Base 30 block extrusion	Type B34-0	EN AW-6060	0.5	-	-	69
Rectangular tube 55x55	Type A19-5	EN AW-6060	1.3	21.58	7.85	69
Rectangular tube 50x50	Type E19-5	EN AW-6060	1.0	14.75	5.9	69
Rectangular tube 45x45	Type C19-5	EN AW-6060	1.0	11.4	5.06	69
Rectangular tube 35x35	Type B19-5	EN AW-6060	0.7	4.8	2.74	69
Counterweight extrusion 50x100	Type A19-2	EN AW-6063	3.3	41.82, 16.43	8.36, 6.57	69

## Extrusion tolerances, extract from EN 12020-2

### 1. Straightness tolerances

Cavity extrusions may not exceed the values stated in the table for the straightness tolerances  $h_1$ . The deviation  $h_2$  may not exceed a maximum of 0.3 mm over any length of  $l_2 = 0.3$  mm.

Length $l_1$ in m	up 1 m	up 2 m	up 3 m	up 4 m	up 5 m	up 6 m
Tolerance $h_1$ in mm	0.7	1.3	1.8	2.2	2.6	3.0

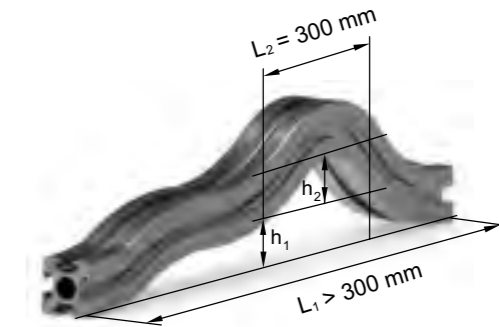

### 2. Twist tolerance v

The length-dependent twist tolerance  $v$  for cavity extrusions is shown in the table.

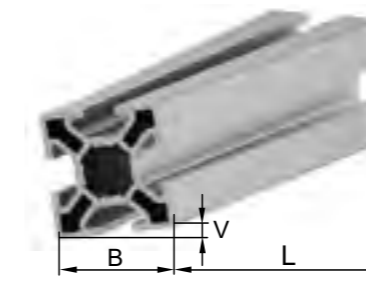

Width b in mm	Flatness tolerance v in mm for lengths in mm					
	- 1000	> 1000-2000	- 2000-3000	> 3000-4000	> 4000-5000	> 5000-6000
- 25	1.0	1.5	1.5	2.0	2.0	2.0
> 25 - 50	1.0	1.2	1.5	1.8	2.0	2.0
> 50 - 75	1.0	1.2	1.2	1.5	2.0	2.0
> 75 - 100	1.0	1.2	1.5	2.0	2.2	2.5
> 100 - 125	1.0	1.5	1.8	2.2	2.5	3.0
> 125 - 150	1.2	1.5	1.8	2.2	2.5	3.0
> 150 - 200	1.5	1.8	2.2	2.6	3.0	3.5
> 200 - 300	1.8	2.5	3.0	3.5	4.0	4.5

### 3. Inclination tolerance w

Where sides are of unequal length, inclination tolerance shall be relative to the angle of the shorter side.

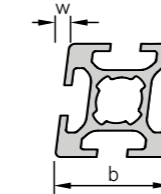

Width b in mm	Inclination tolerance w in mm	Width b in mm	Inclination tolerance w in mm
- 30	0.3	> 120 - 140	0.8
> 30 - 50	0.4	> 140 - 160	0.9
> 50 - 80	0.5	> 160 - 180	1.0
> 80 - 100	0.6	> 180 - 200	1.2
> 100 - 120	0.7	> 200 - 240	1.5

### 4. External tolerances

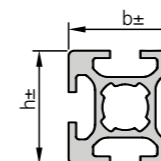

Width b, h in mm	Deviation in mm	Width b, h in mm	Deviation in mm
> 15 - 30	± 0.25	> 120 - 150	± 0.80
> 30 - 45	± 0.30	> 150 - 180	± 1.00
> 45 - 60	± 0.40	> 180 - 240	± 1.20
> 60 - 90	± 0.45	> 240 - 300	± 1.50
> 90 - 120	± 0.60		

## Strength calculations

Load case 1

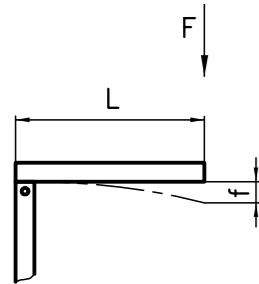

$$f [\text{mm}] = \frac{0.476 \times F [\text{N}] \times L^2 [\text{m}]}{I [\text{cm}^4]}$$



### Example:

A counterweight with a max. load of 500 N is to be fastened to an extruded arm 800 mm long. What will be the deflection of a 40x40 mm C01-1 type base extrusion?

$$\text{Deflection } f = \frac{0.476 \times 500 \times 0.8^2}{11.70} = 10.42 \text{ mm}$$

### Checking the bending stress:

$$\delta = \frac{M_b}{W \times 10^3}$$

$\delta$  = bending stress in N/mm<sup>2</sup>  
 $M_b$  = max. bending moment in Nmm  
 $W$  = section modulus in cm<sup>3</sup>

### Example:

An 1800 N load is placed in the middle of a beam. The unsupported length is 1200 mm. The max. permissible deflection is 1.0 mm. What sort of extrusion should be used for the beam?

$$\text{Deflection } f = \frac{0.0074 \times F \times L^3}{I} \Rightarrow I = \frac{0.0074 \times F \times L^3}{f}$$

$$\text{Moment of inertia } I = \frac{0.0074 \times 1800 \times 1.2^3}{1.0} = 23.02 \text{ cm}^4$$

⇒ Selection: Use a heavy duty extrusion MA1-1 where  $I = 29.37 \text{ cm}^4$

Load case 2

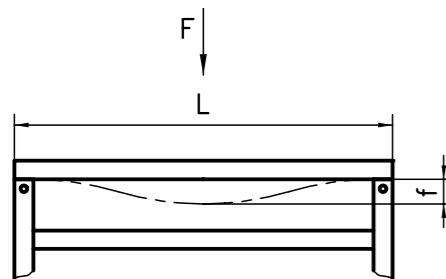

$$f [\text{mm}] = \frac{0.0074 \times F [\text{N}] \times L^3 [\text{m}]}{I [\text{cm}^4]}$$



Load case 3

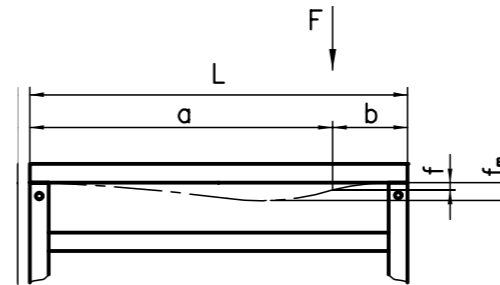

$$f [\text{mm}] = \frac{0.476 \times F [\text{N}] \times a^2 [\text{m}] \times b^2 [\text{m}]}{I [\text{cm}^4] \times L^3 [\text{m}]}$$



### Example:

A cross-beam measuring 2500 mm in width has to support another beam 850 mm from the end of the cross-beam. The support load is 1200 N. A 50 x 100 base extrusion is used as the cross-beam. How great is the deflection at the point where the beam is placed?

$$\text{Deflection } f = \frac{0.476 \times 1200 \times 1.65^3 \times 0.85^3}{149.84 \times 2.5^3} = 0.67 \text{ mm}$$

### Where:

$F$  = load in N  
 $L$  = extrusion length in m  
 $I$  = moment of inertia in cm<sup>4</sup>  
 $f$  = deflection in mm  
 $a/b$  = distance to the load point in m  
 $q$  = line load in N/m

$a > b$   $f_m [\text{mm}] = \frac{0.952 \times F [\text{N}] \times a^2 [\text{m}] \times b^2 [\text{m}]}{I [\text{cm}^4] \times L^2 [\text{m}]} \left( \frac{L [\text{m}]}{L [\text{m}] + 2a [\text{m}]} \right)^2$

$a < b$   $f_m [\text{mm}] = \frac{0.952 \times F [\text{N}] \times a^2 [\text{m}] \times b^2 [\text{m}]}{I [\text{cm}^4] \times L^2 [\text{m}]} \left( \frac{L [\text{m}]}{L [\text{m}] + 2b [\text{m}]} \right)^2$

Load case 4

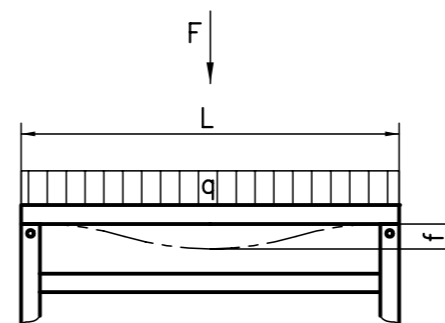

$$f [\text{mm}] = \frac{0.0037 \times F [\text{N}] \times L^3 [\text{m}]}{I [\text{cm}^4]}$$

$$F = q \times L$$



### Example:

A measuring plate (whose intrinsic stability is ignored) may not bend by more than 0.4 mm. The measuring table is 1500 mm deep and the line load on each side of the table is 8000 N/m. Which extrusion must be used to support the measurement plate?

$$F = q \times L = 8000 \times 1.5 = 12000 \text{ N}$$

$$\text{Deflection } f = \frac{0.0037 \times F \times L^3}{I} \Rightarrow I = \frac{0.0037 \times F \times L^3}{f}$$

$$\text{Moment of inertia } I = \frac{0.0037 \times 12000 \times 1.5^3}{0.4} = 374.64 \text{ cm}^4$$

⇒ Selection: Use a heavy duty extrusion MA1-5 (100 x 100) where  $I = 380.00 \text{ cm}^4$

All calculation examples are based on clamped condition.

All calculation examples are based on clamped condition.

## Ordering overview Extrusion machining codes

The order number is made up of the type of extrusion, with the machining code for each end and the length of the extrusion. The available codes for the machining are listed on the following chart. The code covers the most standard machining.

Special machinings are indicated with the order code «-99». In this case, a customer drawing is requested!

### An item number is made up of the following:

- ① Select the appropriate design or special extrusion (extrusion type)
- ② Define the machining on the left side of the extrusion according to the following overview if the left side of the extrusion is to be left unmachined: Code -02
- ③ Define the machining on the right side of the extrusion according to the following overview if the right side of the extrusion is to be left unmachined: Code -02
- ④ Indicate the required extrusion length in mm/L

Special machining:

- ⑤ -99

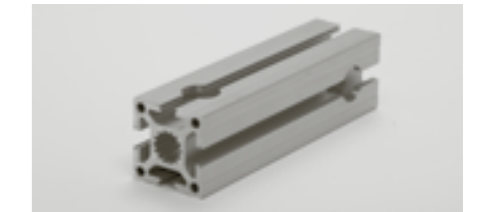

Order number  
with standard machining

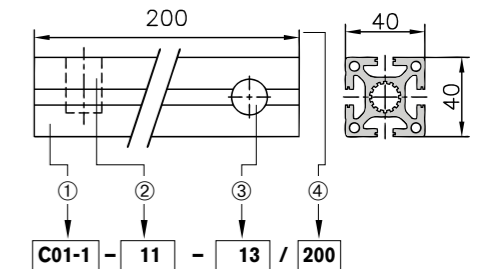

Order number  
with additional special machining, the order code also indicates -99

Example: C01-1 - 11 - 13 - 99 / 200

### MACHINING INFORMATION

### CODES

1.	<b>Cutting the extrusions to length without any other machining</b> Extrusion cut to length, tolerance acc. to ISO 2768-m Example: C01-1-02-02/L		-02
2a.	<b>Cutting the extrusions to length and the main threads</b>		
	1 thread M16 / M14 x thread length 50mm M16 / M14 x thread length 100mm M16 / M14 x thread length 25mm		-E1 -03 -E3
	1 Heli-Coil insert M6 x ~10mm (only for Ø 6mm)*		-H3
	2 thread M16 / M14 x thread length 50mm M16 / M14 x thread length 100mm M16 / M14 x thread length 25mm		-E2 -04 -E4
	2 Heli-Coil inserts M6 x ~10mm (only for Ø 6mm)*		-H4

\* Only for 20 base extrusions with core Ø 6mm

# Extrusion machining information



**MACHINING INFORMATION**

**CODES**

2a. Cutting the extrusions to length and the main threads				
3 threads	M16 / M14 x thread length 50 M16 / M14 x thread length 100 M16 / M14 x thread length 25			-G3 -05 -E5
4 threads	M16 / M14 x thread length 50 M16 / M14 x thread length 100 M16 / M14 x thread length 25			-G4 -06 -E6
6 threads	M16 / M14 x thread length 50 M16 / M14 x thread length 100 M16 / M14 x thread length 25			-G5 -G6 -E7
8 threads	M16 / M14 x thread length 50 M16 / M14 x thread length 100 M16 / M14 x thread length 25			-G7 -G8 -E8
2b. Cutting the extrusions to length and auxiliary threads in the corners				
4 threads	M6 x thread length 15mm			-07
4 threads	M8 x thread length 20mm			-08
	Example: C01-1-07-02/L on one side 4x M6x15			
2c. Cutting the extrusions to length and threads according to drawing				
	X thread acc. to customer drawing			-09

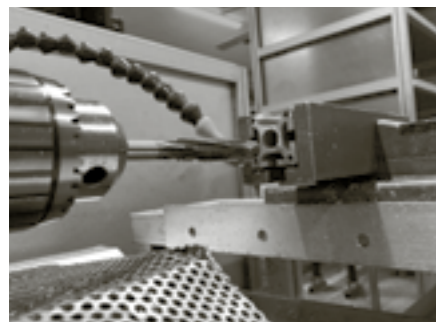

**MACHINING INFORMATION**

**CODES**

3. Cutting the extrusions to length and PVS® drilling				
1 PVS® hole	Symbolic representation of the extrusion cross-sections			-10 -11 -12 -13 -19
1 PVS® hole acc. to customer drawing				
2 PVS® holes	Symbolic representation of the extrusion cross-sections			-20 -21 -23 -29
2 PVS® holes acc. to customer drawing				
3 PVS® holes	Symbolic representation of the extrusion cross-sections			-30 -33 -39
3 PVS® holes acc. to customer drawing				

\*A different arrangement of the holes must be indicated on the drawing.

**MACHINING INFORMATION**

**CODES**

**3. Cutting the extrusion to length and PVS® drilling**

4 PVS® holes

Symbolic representation of the extrusion cross-sections

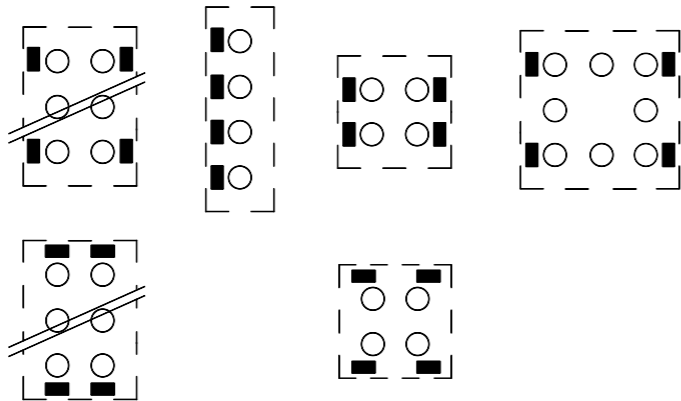
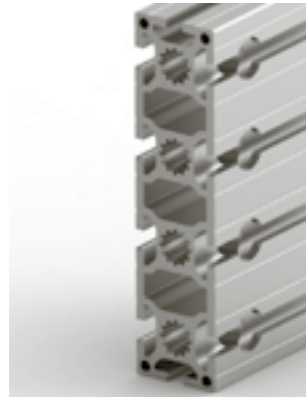

-40

4 PVS® holes acc. to customer drawing

-49

6 PVS® holes

Symbolic representation of the extrusion cross-sections

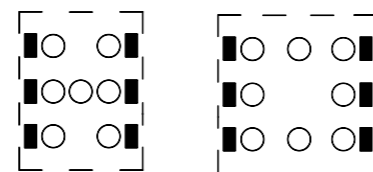
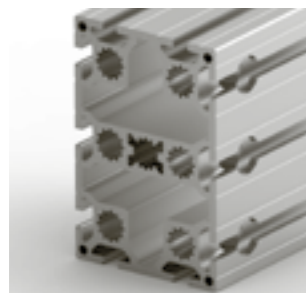

-60

6 PVS® holes acc. to customer drawing

-69

8 PVS® holes

Symbolic representation of the extrusion cross-sections

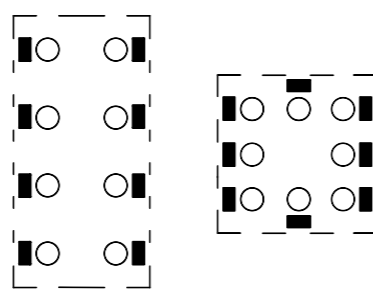
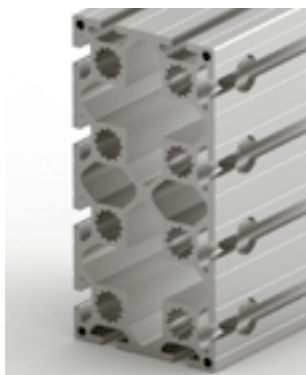

-80

8 PVS® holes acc. to customer drawing

-89

**MACHINING INFORMATION**

**CODES**

**4. Mitre cut extrusions left right**

For mitre cuts on non-symmetrical extrusions, a drawing or sketch is required.

Mitre cut 45° (all extrusions)

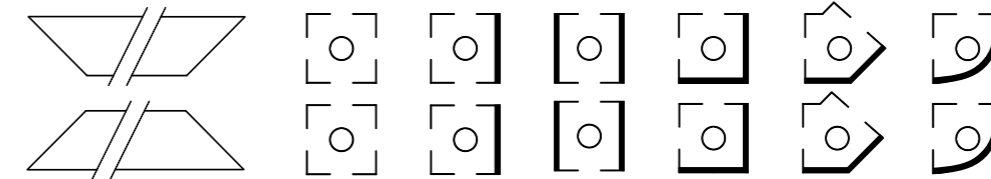

Mitre cut

acc. to customer drawing

left right

-50 -50

-51 -51

-59 -59

**5. Mitre cut extrusions with PVS®-drilling**

Mitre cut 45° + PVS® hole (extrusions 50x50/45x45/40x40/30x30/20x20)

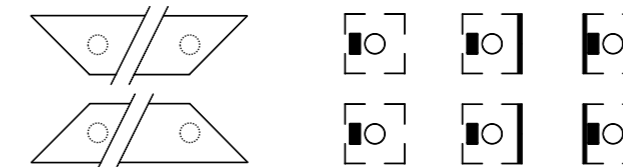

Mitre cut 45° + 2 PVS® holes

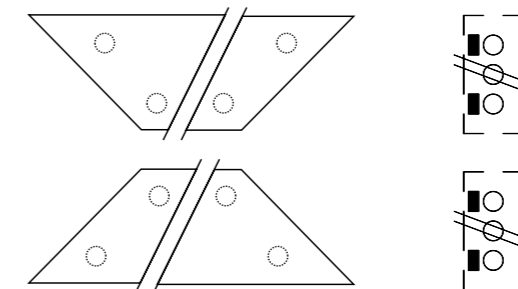

Mitre cut 45° + 4 PVS® holes

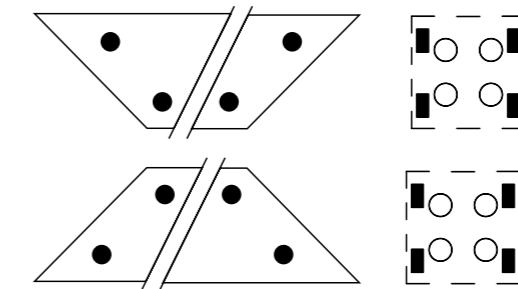

Mitre cut + PVS® hole(s) acc. to customer drawing

-70 -70

-71 -71

-72 -72

-73 -73

-74 -74

-75 -75

-79 -79

**6. Special machining**

All machining which cannot be indicated by a code

-99

## Extrusion machining information

### Application

The drill jig and special drill bits make it easy to drill the holes for KANYA's patented PVS® connector. The main advantage of the drill jig is that it clamps directly onto the extrusion. The rotating stop, for square or mitred cuts, guarantees the precise drilling distance.

The HSS special drill bit, with the MT2 Morse taper shank, is ground flat to cut the extrusion surface. It can be re-sharpened as often as necessary.

A special drill bit with a 90° point is used to drill the C03-8, B01-8 softline extrusion and the A02-8 and C02-8 angle extrusions.

### Standard 90° joint "25" stop

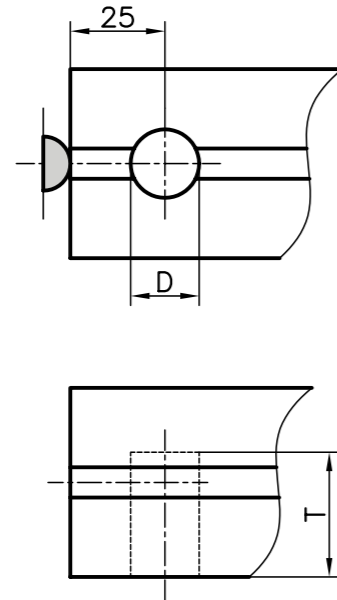

### Mitre joint "32" stop

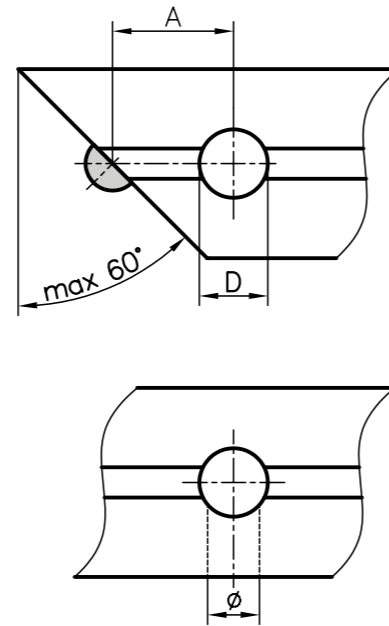

That drill, allows a connection for a parallel connector at any position at the extrusion.



### Machining data

Extrusion type	D	Ø	A	T
50 base	18.1	13.7	32	33
45 base	18.1	13.7	32	30.5
40 base	18.1	13.7	32	28
30 base	15.1	12.1	32	21.5
20x47/95/150 base	15.1		32	18
20 base*	7.3		25	

\* with a centre hole ø 6mm

### Note

The 7.3 mm Ø holes for 20x20/40 extrusions are drilled using a normal twist drill bit without a drill jig.

### Order data Order number

<b>Drill jig</b>	
50/45/40/30 base	AB95-0
<b>Special drill bits</b>	
to fit the drill jig	
50/45/40 base	A96-1
30 base	B96-2
A02-8, C02-8, C03-8 extrusions	A96-3
B01-8 extrusions	B96-3

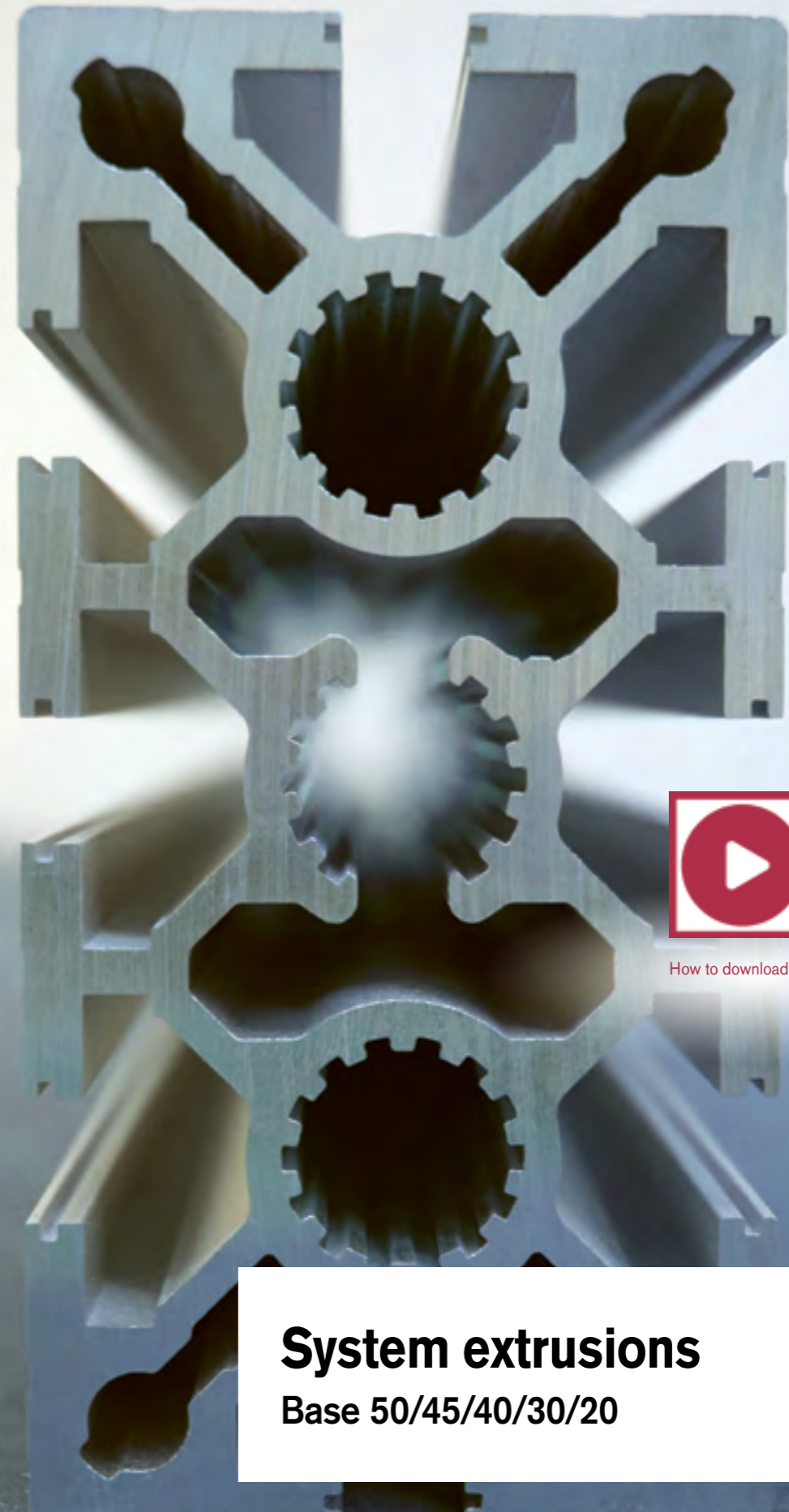

How to download CAD data?

**System extrusions**  
Base 50/45/40/30/20

### Four sided softline extrusion 50x50 type A10-0

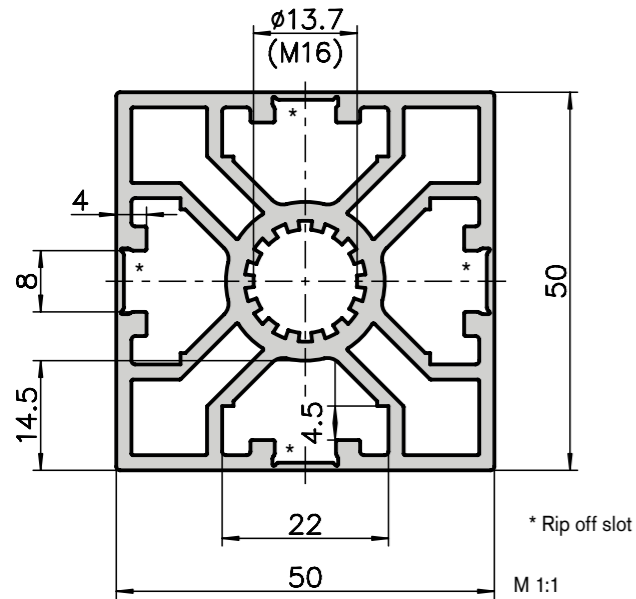

#### Application

The 50 series Softline extrusion is used to create stable, attractive and easily washable constructions. Ideal for clean room applications. Due to the small curved corners, there are no dirt grooves with a T-connection. A very decorative extrusion which offers the designer many application possibilities whilst at the same time also being lightweight and inexpensive.

### Lightweight extrusion 50x50 type A02-1

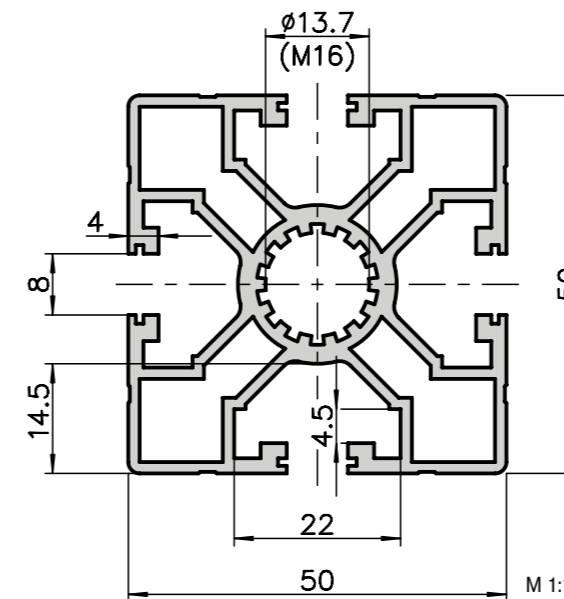

#### Application

The light extrusion 50x50 offers many possibilities to the budget-minded engineer. Whether for machine guarding or machine chassis, in a light build version, this universal extrusion offers tremendous value.

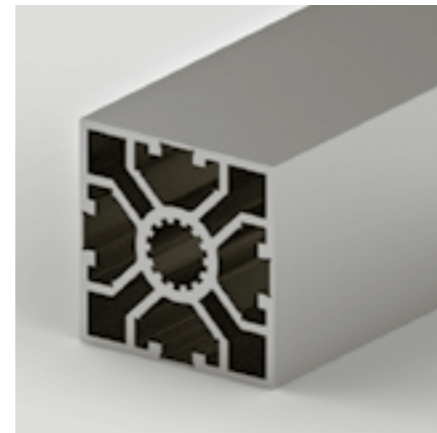

#### Technical data

$I_{x,y}$	=	22.10 cm <sup>4</sup>
$W_{x,y}$	=	8.22 cm <sup>3</sup>
Cross-section area	=	8.38 cm <sup>2</sup>
Weight	=	2.4 kg/m
Alloy	=	EN AW-6060

#### Order data      Order number

Four sided softline extrusion 50x50	
Standard length 5000 mm	A10-0-5M
Four sided softline extrusion 50x50	
Cut to length	A10-0-02-02/...
Extra machining	<a href="#">Pages 24-46</a>

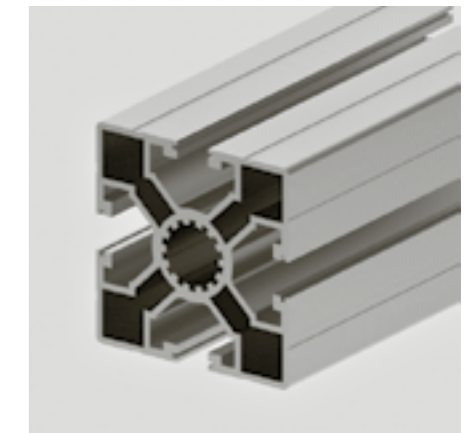
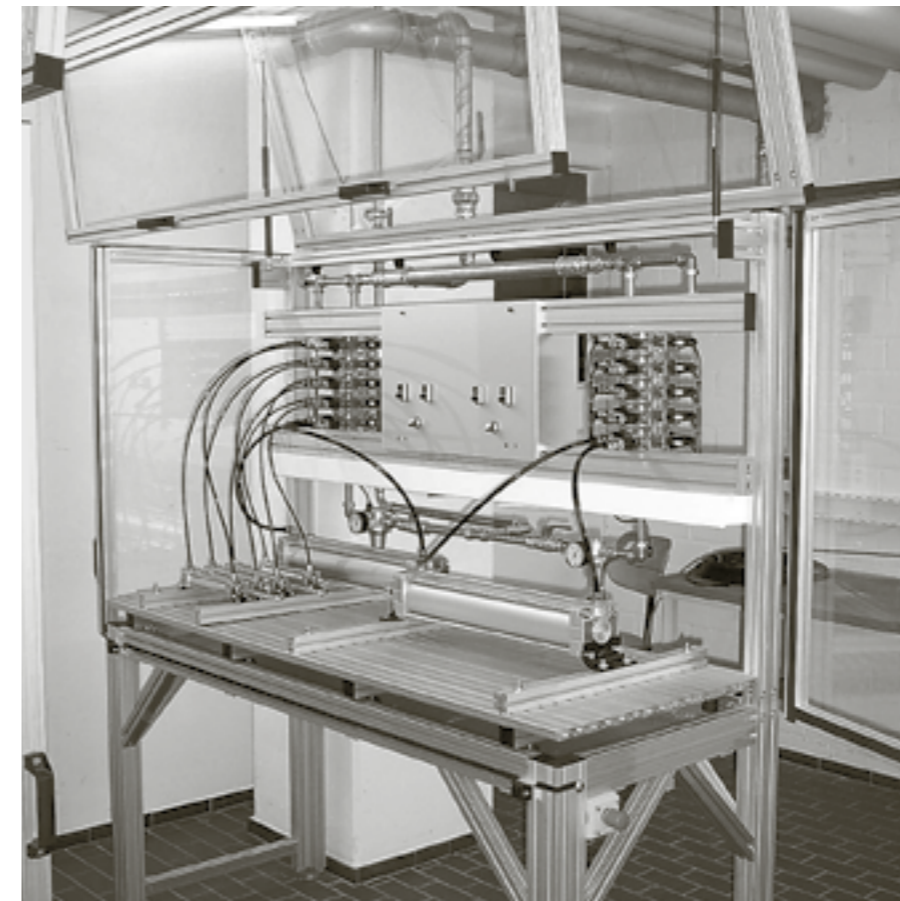

#### Technical data

$I_{x,y}$	=	20.56 cm <sup>4</sup>
$W_{x,y}$	=	6.42 cm <sup>3</sup>
Cross-section area	=	6.71 cm <sup>2</sup>
Weight	=	2.17 kg/m
Alloy	=	EN AW-6063

#### Order data      Order number

Lightweight extrusion 50x50	
Standard length 5000 mm	A02-1-5M
Lightweight extrusion 50x50	
Cut to length	A02-1-02-02/...
Extra machining	<a href="#">Pages 24-46</a>

### 50x50 base extrusion type A01-1

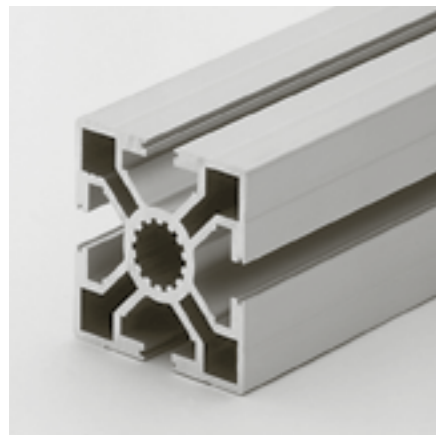
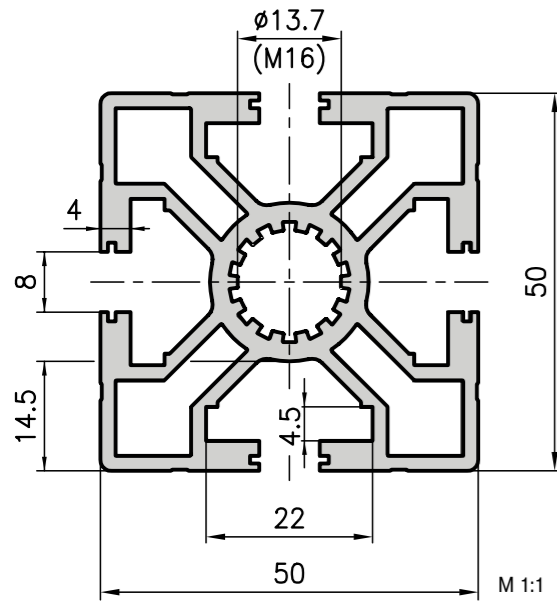

#### Application

These two extrusions are suitable for most design tasks thanks to their excellent weight and strength properties. Their useful features include holes for direct threading and small guide slots to cover the openings in the extrusions with aluminium strips, 0.8x10 [page 97](#).

#### Technical data

$I_{x,y}$	=	20.88 cm <sup>4</sup>
$W_{x,y}$	=	8.35 cm <sup>3</sup>
Cross-section area	=	8.55 cm <sup>2</sup>
Weight	=	2.3 kg/m
Alloy	=	EN AW-6063

#### Order data

Order data	Order number
50x50 base extrusion	
Standard length 5000 mm	A01-1-5M
Standard length 6000 mm	A01-1-6M
50x50 base extrusion	
Cut to length	A01-1-02-02/...

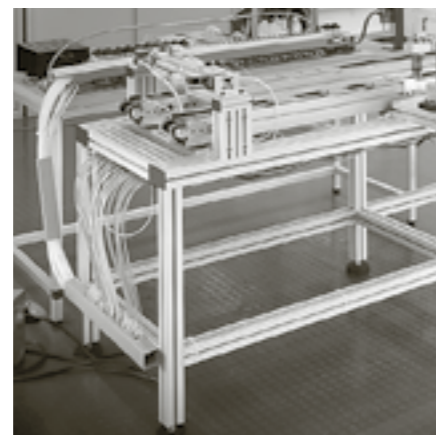

Extra machining

[Pages 24-46](#)

### 50x50 heavy duty extrusion type MA1-1

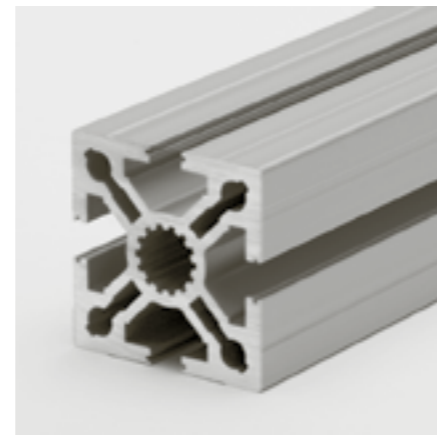
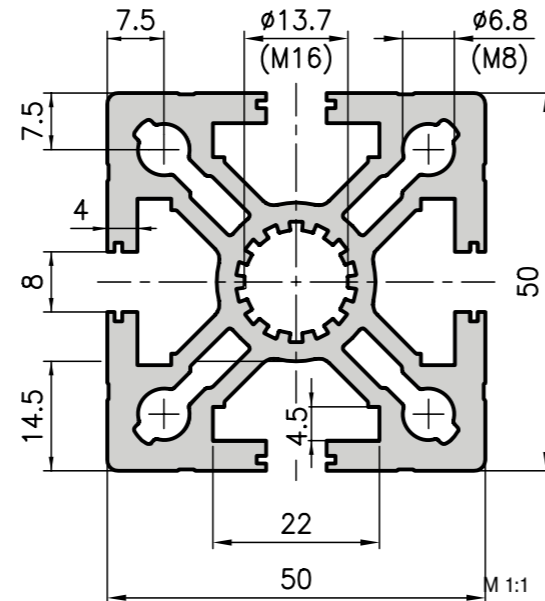

#### Technical data

$I_{x,y}$	=	29.37 cm <sup>4</sup>
$W_{x,y}$	=	11.75 cm <sup>3</sup>
Cross-section area	=	11.26 cm <sup>2</sup>
Weight	=	3.1 kg/m
Alloy	=	EN AW-6063

#### Order data

Order data	Order number
50x50 heavy duty extrusion	
Standard length 5000 mm	MA1-1-5M
Standard length 6000 mm	MA1-1-6M
50x50 heavy duty extrusion	
Cut to length	MA1-1-02-02/...

Extra machining

[Pages 24-46](#)

### 50x50 face extrusion type A01-8

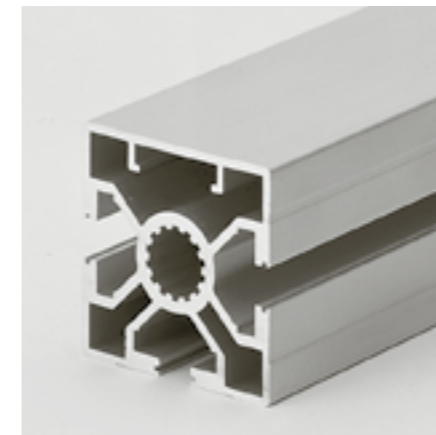
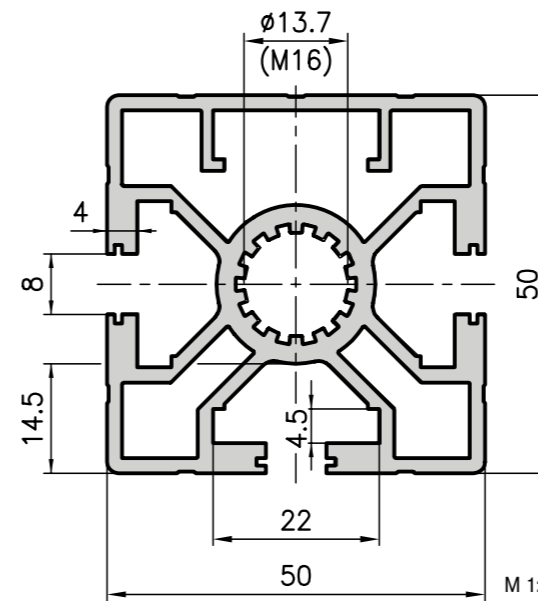

#### Technical data

$I_x$	=	20.38 cm <sup>4</sup>
$I_y$	=	19.61 cm <sup>4</sup>
$W_x$	=	8.15 cm <sup>3</sup>
$W_y$	=	7.55 cm <sup>3</sup>
Cross-section area	=	8.01 cm <sup>2</sup>
Weight	=	2.2 kg/m
Alloy	=	EN AW-6063

#### Order data

Order data	Order number
50x50 face extrusion	
Standard length 5000 mm	A01-8-5M
50x50 face extrusion	
Cut to length	A01-8-02-02/...

#### Application

Corner and face extrusions are used in any applications where closed surfaces are required. The advantages of these are that they improve the appearance of the structures and also minimise the build up of dirt. Extrusions can be fitted onto the closed faces by drilling holes in the outer face of the extrusion at the required points and using AC32-... type threaded plates. The small lugs inside the extrusion guide the plates.



Extra machining

[Pages 24-46](#)

### 50x50 corner extrusion type A01-7

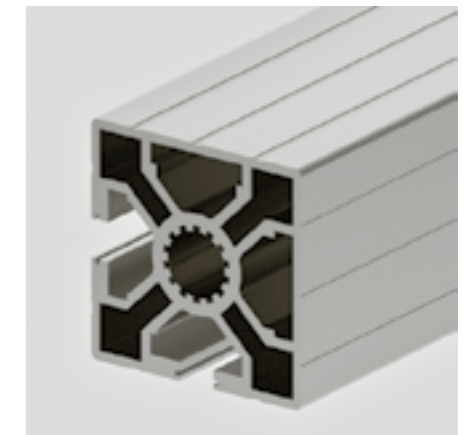
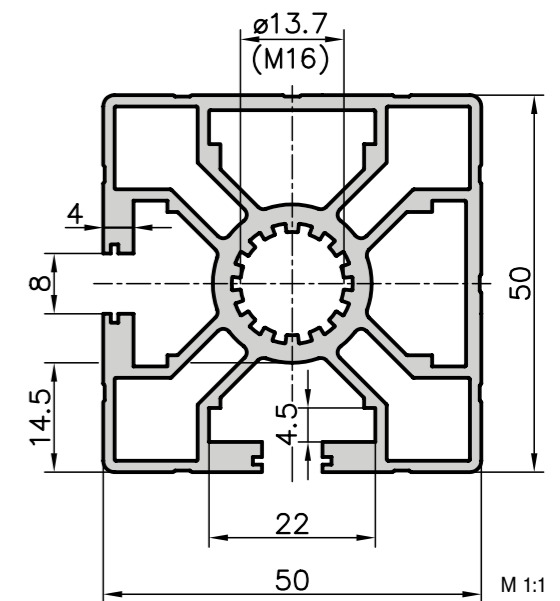

#### Technical data

$I_{x,y}$	=	17.7 cm <sup>4</sup>
$W_{x,y}$	=	7.05 cm <sup>3</sup>
Cross-section area	=	7.5 cm <sup>2</sup>
Weight	=	2.0 kg/m
Alloy	=	EN AW-6060

#### Order data

Order data	Order number
50x50 corner extrusion	
Standard length 5000 mm	A01-7-5M
50x50 corner extrusion	
Cut to length	A01-7-02-02/...

Extra machining

[Pages 24-46](#)

### 50x50 double face extrusion type A02-4

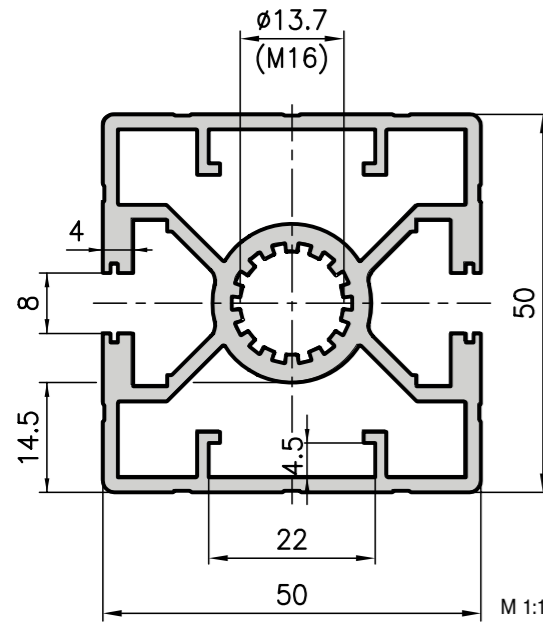

### 50x45° angle extrusion type A02-8

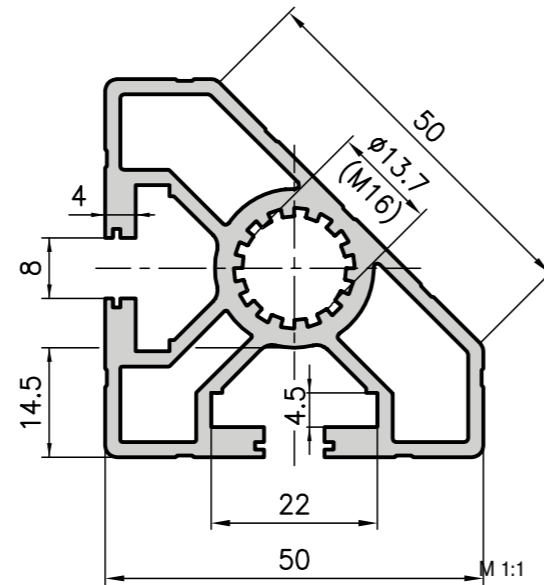

### 50x50 face extrusion with rip off panel slots type A03-8

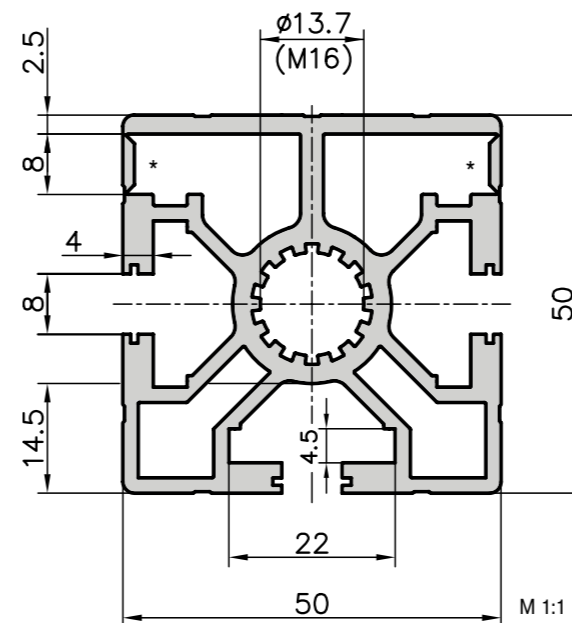

\* Rip off slot

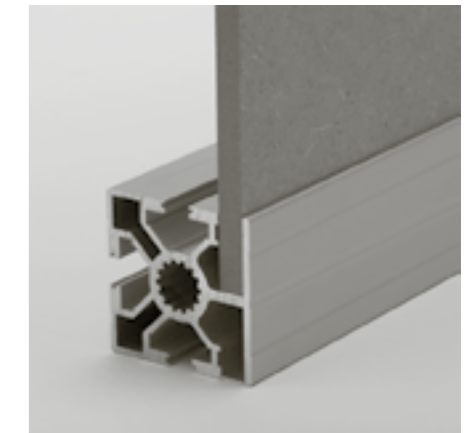
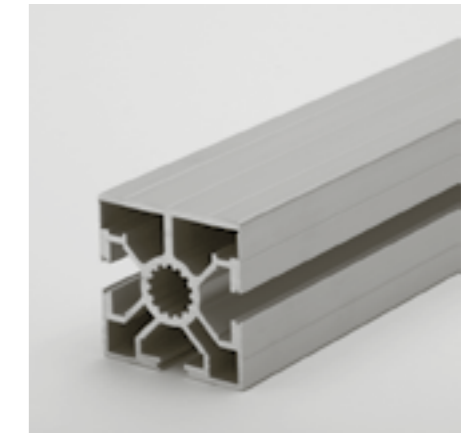

#### Application

For all types of enclosure, as well as for structures with extrusion faces which are mainly closed and for applications with an attractive design.



#### Application

The one face closed extrusion gives the possibility to open a slot to insert a panel, ideal for delicate solar-panels. Rip off the slot, if necessary put in a sealing strip, insert panels and mount the frame. The 8 mm panels fit perfectly in the rip off slot.

#### Technical data

$I_x$	=	19.59 cm <sup>4</sup>
$I_y$	=	18.17 cm <sup>4</sup>
$W_x$	=	7.83 cm <sup>3</sup>
$W_y$	=	7.27 cm <sup>3</sup>
Cross-section area	=	7.39 cm <sup>2</sup>
Weight	=	2.0 kg/m
Alloy	=	EN AW-6063

#### Order data

Order data	Order number
50x50 double face extrusion Standard length 5000 mm	A02-4-5M
50x50 double face extrusion Cut to length	A02-4-02-02/...
Extra machining	<a href="#">Pages 24-46</a>



#### Technical data

$I_{x,y}$	=	13.10 cm <sup>4</sup>
$W_{x,y}$	=	4.50 cm <sup>3</sup>
Cross-section area	=	6.40 cm <sup>2</sup>
Weight	=	1.7 kg/m
Alloy	=	EN AW-6063

#### Order data

Order data	Order number
50x45° angle extrusion Standard length 5000 mm	A02-8-5M
50x45° angle extrusion Cut to length	A02-8-02-2/...
Extra machining	<a href="#">Pages 24-46</a>

#### Technical data

$I_x$	=	20.40 cm <sup>4</sup>
$I_y$	=	19.72 cm <sup>4</sup>
$W_x$	=	8.07 cm <sup>3</sup>
$W_y$	=	7.89 cm <sup>3</sup>
Cross-section area	=	8.28 cm <sup>2</sup>
Weight	=	2.2 kg/m
Alloy	=	EN AW-6063

#### Order data

Order data	Order number
50x50 face extrusion with rip off slot Standard length 5000 mm	A03-8-5M
50x50 face extrusion with rip off slot Cut to length	A03-8-02-02/...
Extra machining	<a href="#">Pages 24-46</a>



### Light extrusion 50x100 type A02-2

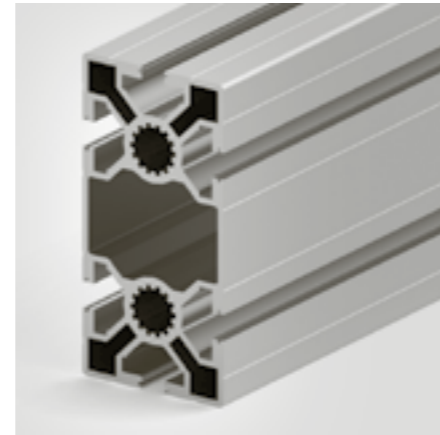
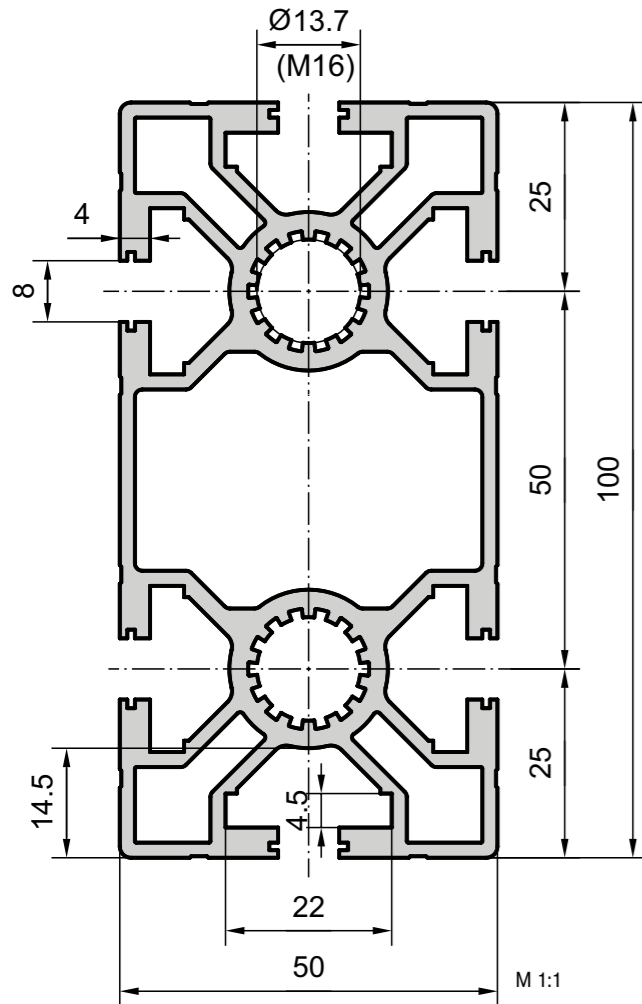

Technical data	
$I_x$	= 148.15 cm <sup>4</sup>
$I_y$	= 37.15 cm <sup>4</sup>
$W_x$	= 29.63 cm <sup>3</sup>
$W_y$	= 15.00 cm <sup>3</sup>
Cross-section area	= 14.15 cm <sup>2</sup>
Weight	= 3.8 kg/m
Alloy	EN AW-6063

**Application**  
The new lightweight extrusion is suitable for stable basic constructions and also universally applicable. Additionally the weight versus rigidity ratio is excellent.

Order data	Order number
Light extrusion 50x100	
Standard length 5000 mm	A02-2-5M
Light extrusion 50x100	
Cut to length	A02-2-02-02/...
Extra machining	<a href="#">Pages 24-46</a>

### 50x100 base extrusion type A01-2

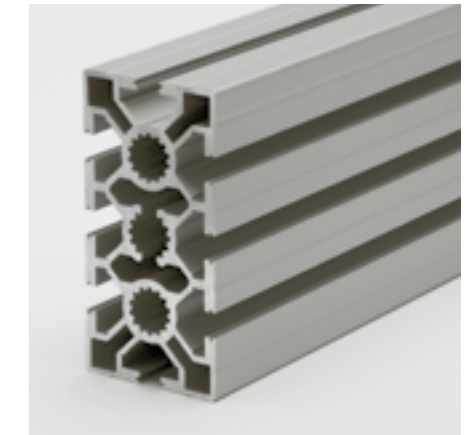
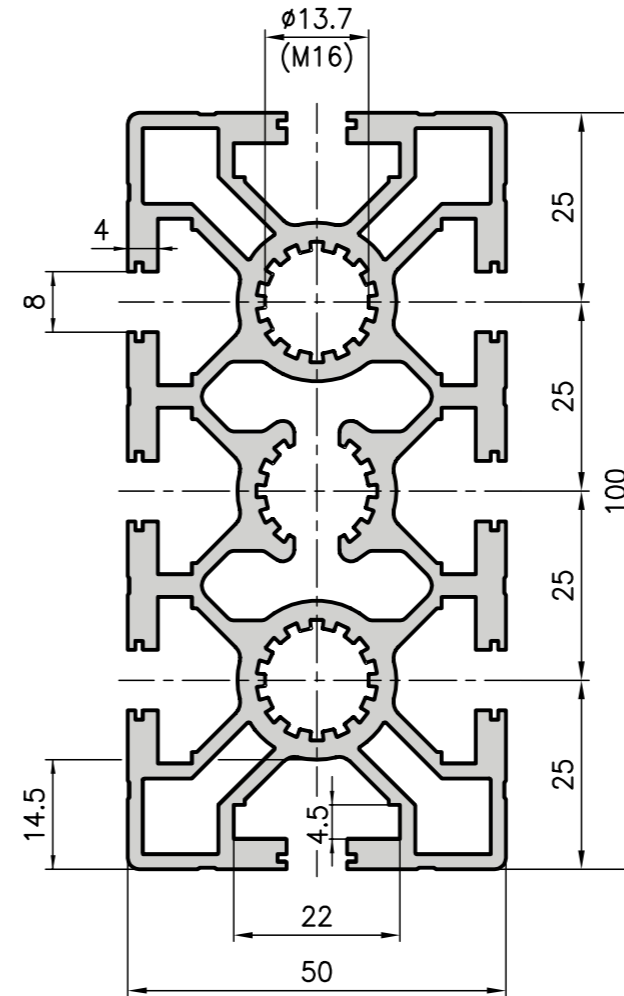

Technical data	
$I_x$	= 149.84 cm <sup>4</sup>
$I_y$	= 41.25 cm <sup>4</sup>
$W_x$	= 29.97 cm <sup>3</sup>
$W_y$	= 16.50 cm <sup>3</sup>
Cross-section area	= 16.84 cm <sup>2</sup>
Weight	= 4.6 kg/m
Alloy	EN AW-6063

**Application**  
This base extrusion is normally used for cross-beams. Further, its optimised cross section means that it is ideal for an extremely wide range of applications.

Order data	Order number
50x100 base extrusion	
Standard length 5000 mm	A01-2-5M
Standard length 6000 mm	A01-2-6M
50x100 base extrusion	
Cut to length	A01-2-02-02/...
Extra machining	<a href="#">Pages 24-46</a>



### 50x100 heavy duty extrusion type MA1-2

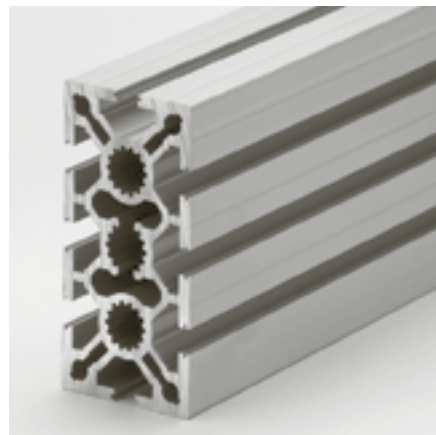
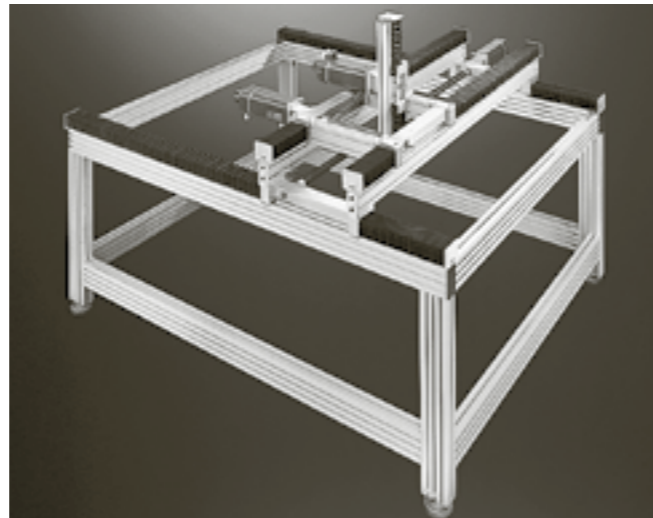
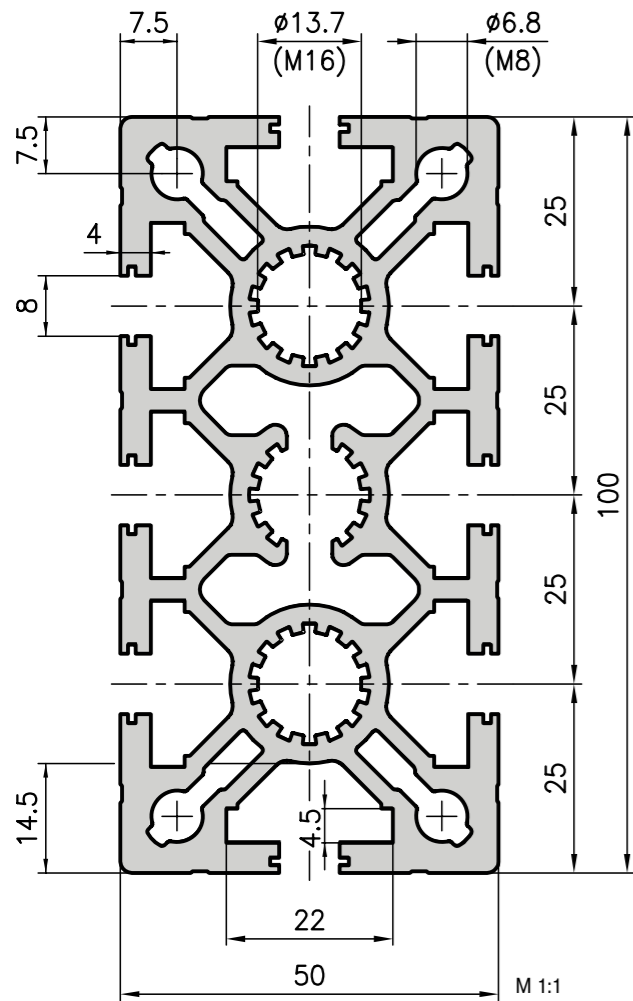

#### Application

The heavy duty extrusion, like the A01-2 type base extrusion, is commonly used as a cross-beam. However, this design can also be used in many different applications combining excellent load-bearing capabilities and a lightweight structure!

#### Technical data

$I_x$	=	198.66 cm <sup>4</sup>
$I_y$	=	50.28 cm <sup>4</sup>
$W_x$	=	39.73 cm <sup>3</sup>
$W_y$	=	20.11 cm <sup>3</sup>
Cross-section area	=	19.79 cm <sup>2</sup>
Weight	=	5.3 kg/m
Alloy	=	EN AW-6063

#### Order data Order number

50x100 heavy duty extrusion	
Standard length 5000 mm	MA1-2-5M
Standard length 6000 mm	MA1-2-6M
50x100 heavy duty extrusion	
Cut to length	MA1-2-02-02/...
Extra machining	<a href="#">Pages 24-46</a>

### 50x100 face extrusion type MA1-4

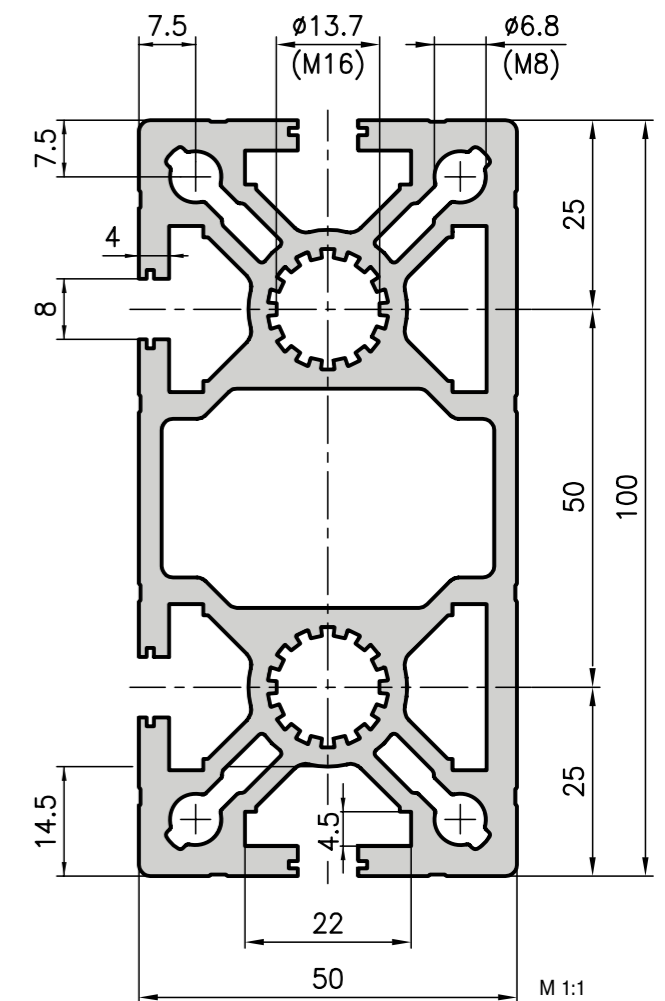

#### Technical data

$I_x$	=	203.67 cm <sup>4</sup>
$I_y$	=	54.31 cm <sup>4</sup>
$W_x$	=	40.73 cm <sup>3</sup>
$W_y$	=	21.03 cm <sup>3</sup>
Cross-section area	=	19.34 cm <sup>2</sup>
Weight	=	5.2 kg/m
Alloy	=	EN AW-6063

#### Order data Order number

50x100 face extrusion	
Standard length 5000 mm	MA1-4-5M
Standard length 6000 mm	MA1-4-6M
50x100 face extrusion	
Cut to length	MA1-4-02-02/...
Extra machining	<a href="#">Pages 24-46</a>

#### Application

An extrusion which boasts all the advantages of the comparable A01-2 and MA1-2. In addition, its large inner cavity can be used to channel air, gas, water, oil, etc. The driving belt on a twin-belt conveyor can also be fed back in this chamber. The sealed face keeps dirt out. The extrusion can be extended using the closed threaded-plate slots. Simply drill a hole, place a threaded plate behind the hole and carry on building!





## Radius extrusion 100x100 Type A03-9

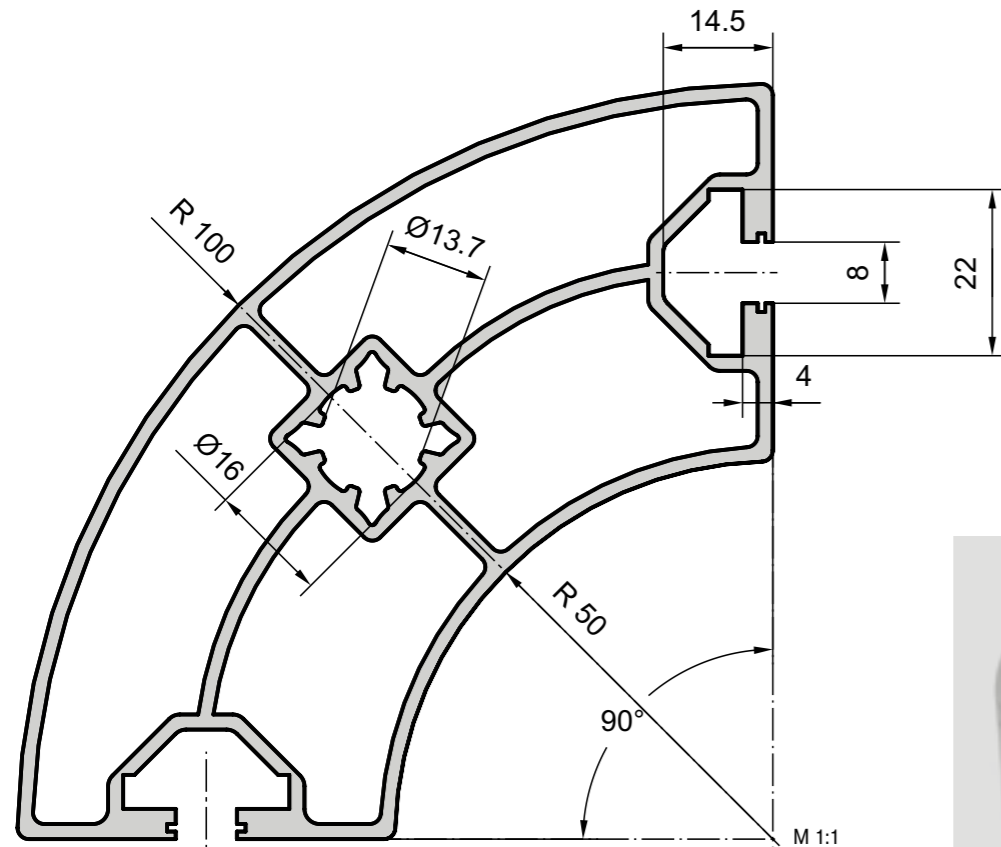

### Application

There is a core hole at the front of the extrusion, which allows easy mounting of an adjustable foot. A cover can be provided by a lasered aluminium plate, This is screwed on by means of a threaded reducing sleeve.

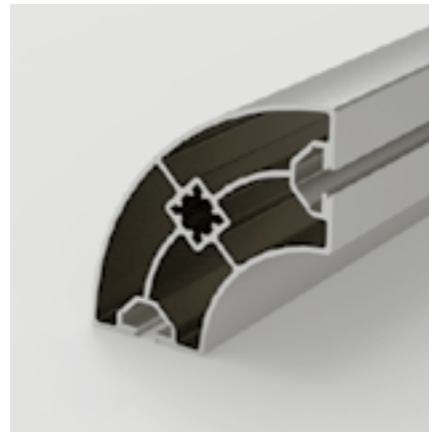

### Technical data

$I_x, y$	=	100.0 cm <sup>4</sup>
$W_x, y$	=	20.0 cm <sup>3</sup>
Cross-section area	=	12.02 cm <sup>2</sup>
Weight	=	3.2 kg/m
Alloy	=	EN AW-6063

### Order data      Order number

Radius extrusion 100x100	
Standard length 5000 mm	A03-9-5M
Radius extrusion 100x100	
Cut to length	A03-9-02-02/...

Extra machining      [Pages 24-46](#)

## 100x100 Base extrusion type MA3-5

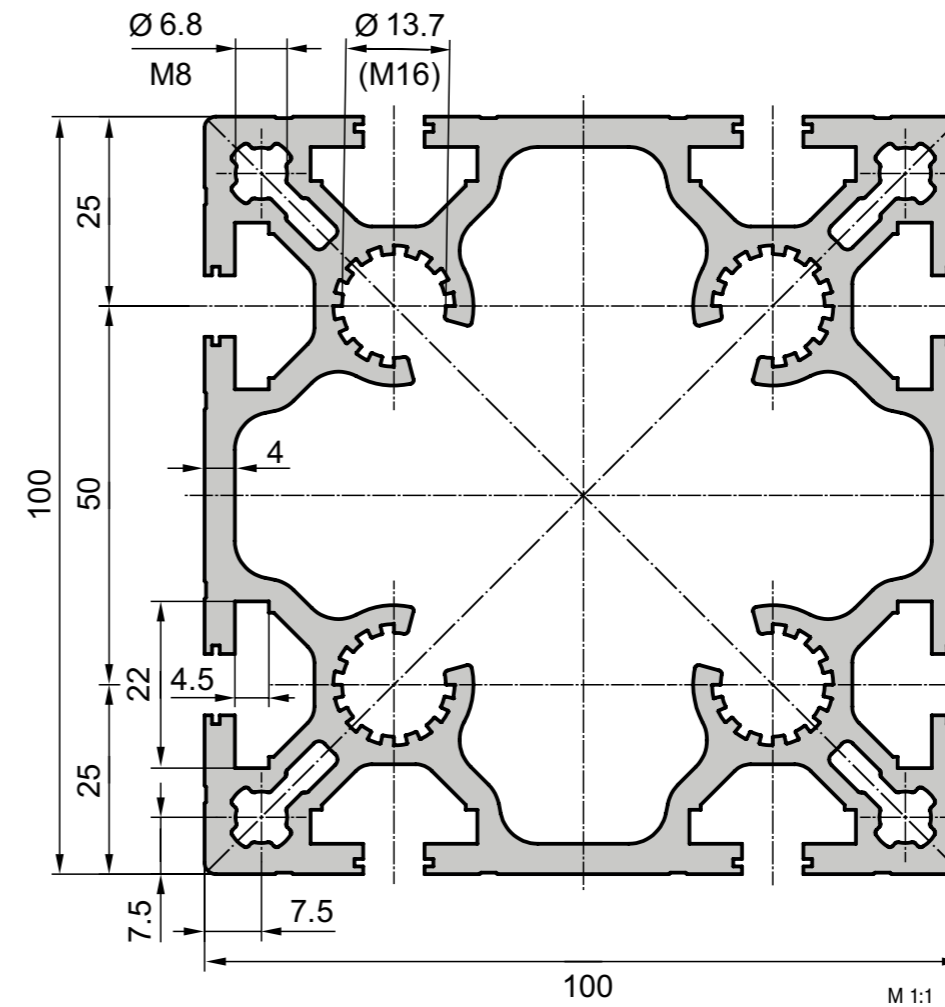

### Application

This versatile extrusion is mainly used in machinery and plant construction and boasts the following qualities: high strength and low weight.

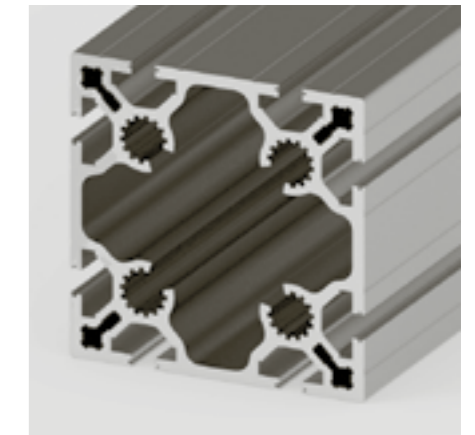

### Technical data

$I_x, y$	=	330.90 cm <sup>4</sup>
$W_x, y$	=	66.018 cm <sup>3</sup>
Cross-section area	=	27.00 cm <sup>2</sup>
Weight	=	7.28 kg/m
Alloy	=	EN AW-6063

### Order data      Order number

100x100 Base extrusion	
Standard length 5000 mm	MA3-5-5M
Standard length 6000 mm	MA3-5-6M

100x100 Base extrusion	
Cut to length	MA3-5-02-02/...

Extra machining      [Pages 24-46](#)



## 100x100 heavy duty extrusion type MA1-5

### Application

An extremely sturdy extrusion which is used as a support, stand or manifold. Ideal for building gantries if used in combination with the 100x200 heavy duty extrusion, MA1-9.

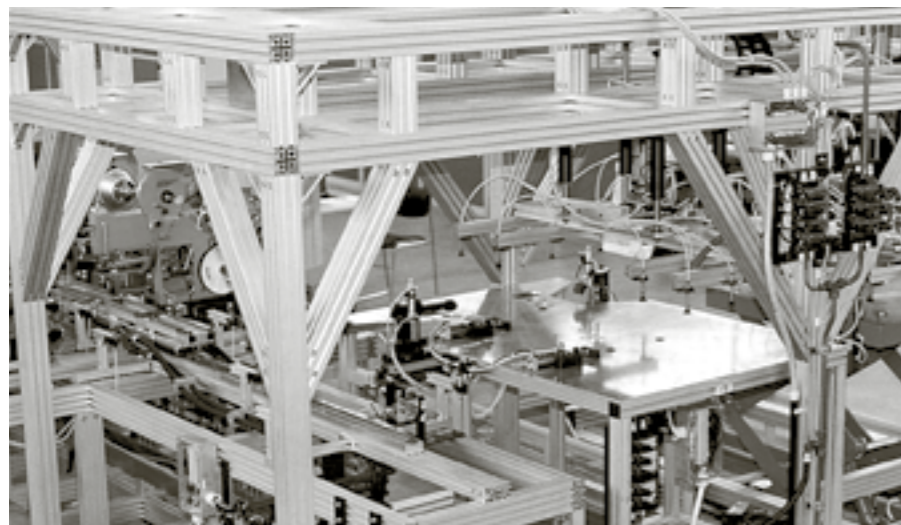
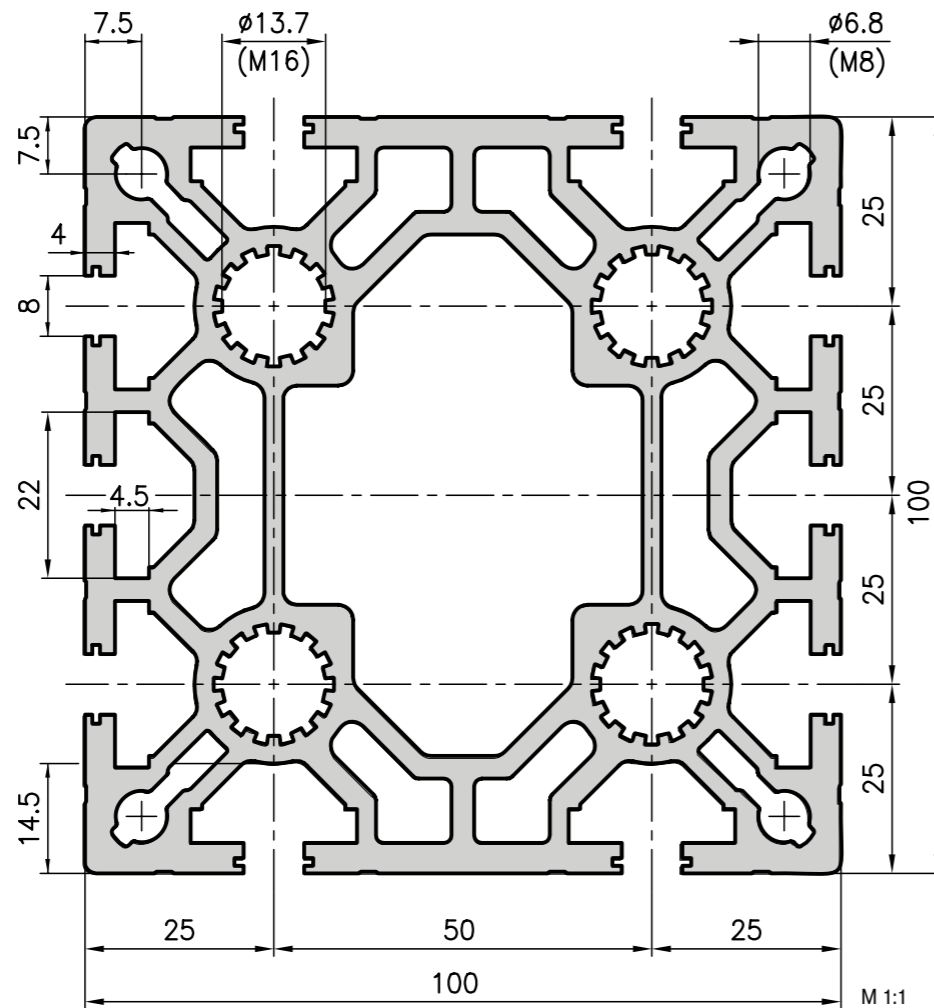
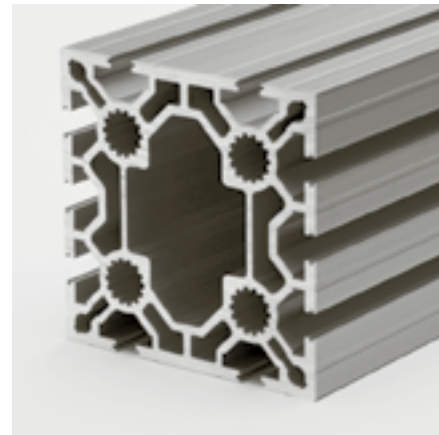

### Technical data

$I_x$	=	363.00 cm <sup>4</sup>
$I_y$	=	345.00 cm <sup>4</sup>
$W_x$	=	76.00 cm <sup>3</sup>
$W_y$	=	73.00 cm <sup>3</sup>
Cross-section area	=	35.19 cm <sup>2</sup>
Weight	=	8.9 kg/m
Alloy	=	EN AW-6063

### Order data

Order data	Order number
100x100 heavy duty extrusion	
Standard length 5000 mm	MA1-5-5M
Standard length 6000 mm	MA1-5-6M
100x100 heavy duty extrusion	
Cut to length	MA1-5-02-02/...

## Corner extrusion 100x100 Type A03-7

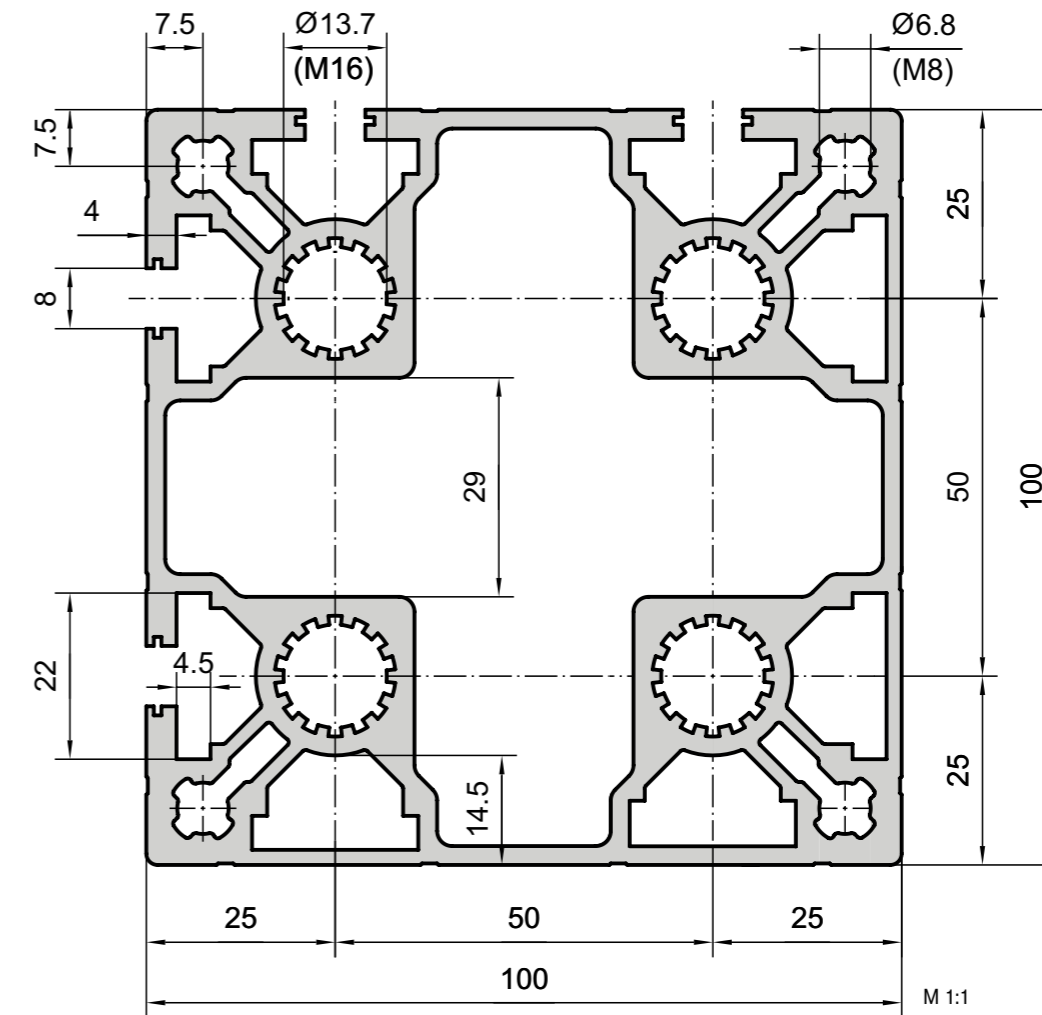

### Technical data

$I_x, y$	=	314.10 cm <sup>4</sup>
$W_x, y$	=	62.82 cm <sup>3</sup>
Cross-section area	=	26.30 cm <sup>2</sup>
Weight	=	7.10 kg/m
Alloy	=	EN AW-6063

### Order data

Order data	Order number
Corner extrusion 100x100	
Standard length 5000 mm	A03-7-5M
Corner extrusion 100x100	
Cut to length	A03-7-02-02/...
Extra machining	<a href="#">Pages 24-46</a>

### Application

Corner extrusions are always used when closed surfaces are required. Particularly with larger machine casings, this extrusion is frequently used as a corner pillar that can absorb weight at the same time, but also optimises the look of the machine. With a base plate (A47-80) a central adjustable foot can also be installed.

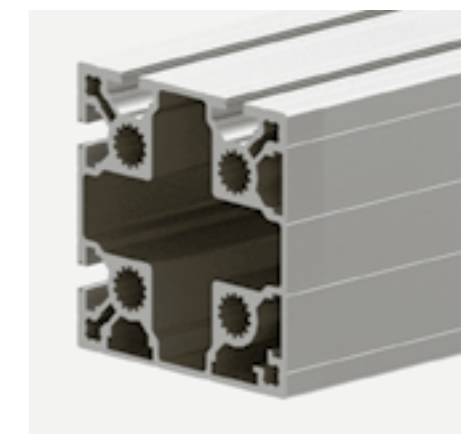

### 50x150 beam extrusion type MA1-3

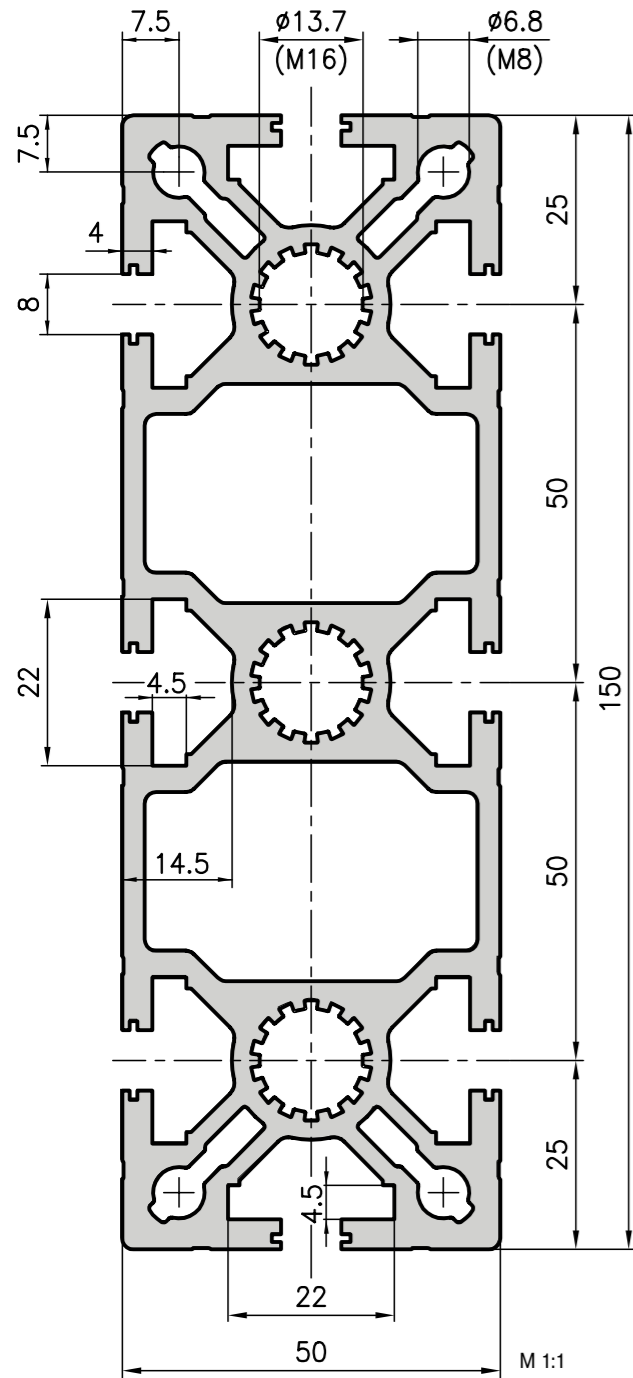

#### Application

This extrusion is mainly used to support heavy loads because of its excellent load-bearing characteristics. However, it is also an effective manifold extrusion.

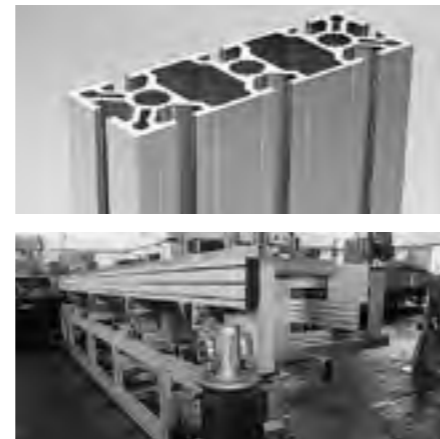

#### Technical data

$I_x$	=	599.80 cm <sup>4</sup>
$I_y$	=	71.90 cm <sup>4</sup>
$W_x$	=	81.11 cm <sup>3</sup>
$W_y$	=	29.42 cm <sup>3</sup>
Cross-section area	=	26.04 cm <sup>2</sup>
Weight	=	7.0 kg/m
Alloy	=	EN AW-6063

#### Order data

Order data	Order number
50x150 bearing extrusion	
Standard length 5000 mm	MA1-3-5M
Standard length 6000 mm	MA1-3-6M
50x150 bearing extrusion	
Cut to length	MA1-3-02-02/...
Extra machining	<a href="#">Pages 24-46</a>

### Beam extrusion 50x200 type MA1-6

#### Application

An optimum extrusion for large gantries and stable cross-beams. Together with the extrusion MA1-9, large robust constructions can be created. Similar to the MA1-3, this extrusion is mainly used to support heavy loads because of its excellent load-bearing characteristics.

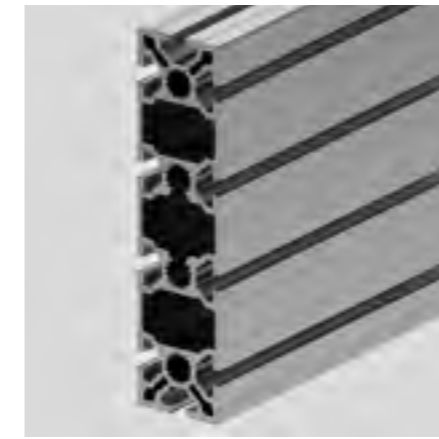

#### Technische Daten

$I_x$	=	1315.83 cm <sup>4</sup>
$I_y$	=	92.71 cm <sup>4</sup>
$W_x$	=	131.58 cm <sup>3</sup>
$W_y$	=	37.08 cm <sup>3</sup>
Cross-section area	=	32.74 cm <sup>2</sup>
Weight	=	8.84 kg/m
Alloy	=	EN AW-6063

#### Order data

Order data	Order number
Beam extrusion 50x200	
Standard length 6000 mm	MA1-6-6M
Beam extrusion 50x200	
Cut to length	MA1-6-02-02/...
Extra machining	<a href="#">Pages 24-46</a>

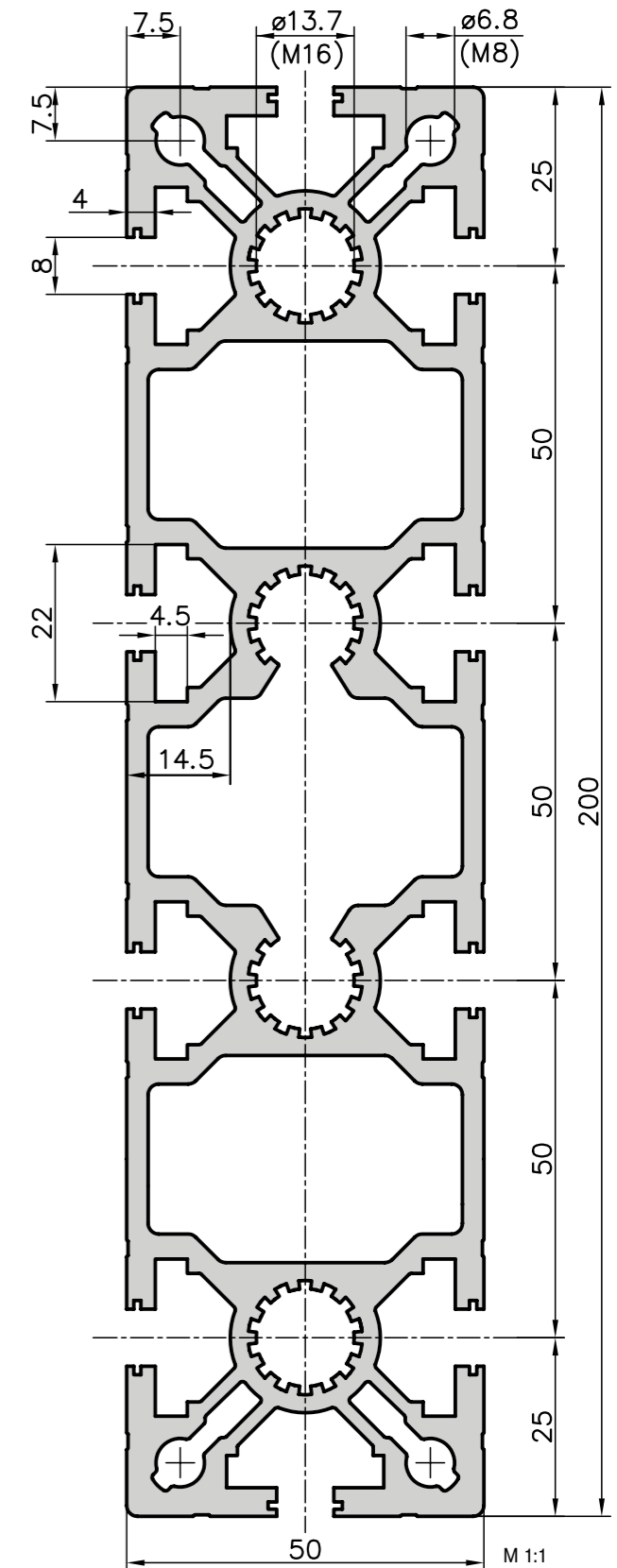



### Four sided softline extrusion 45x45 Type E10-1

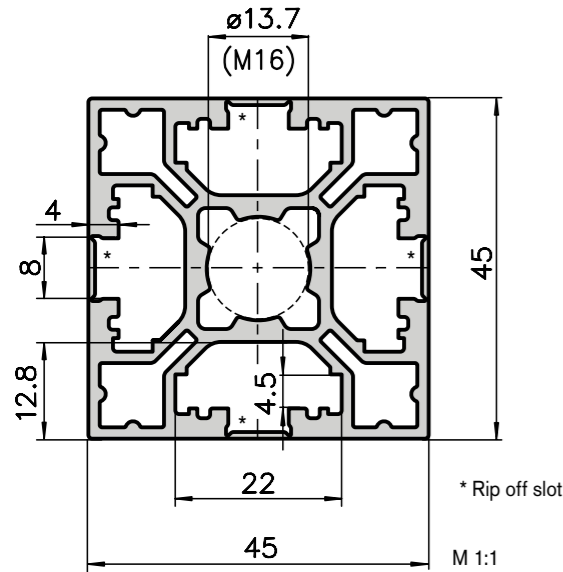

#### Application

The four sided softline extrusion 45x45 features an absolutely smooth surface. For this reason it is ideally suitable for clean room technology. The stable and elegant profile is easily washable. All connections are possible, thanks to the rip off slots.

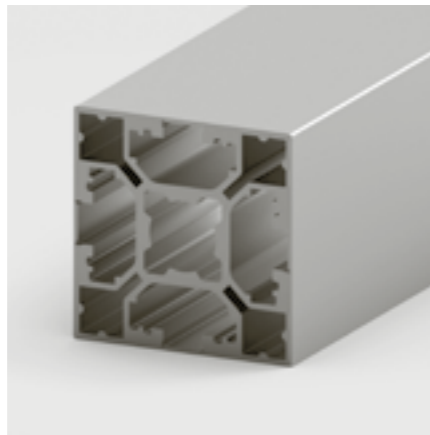

Technical data	
Ix, y	= 14.07 cm <sup>4</sup>
Wx, y	= 6.25 cm <sup>3</sup>
Cross-section area	= 6.75 cm <sup>2</sup>
Weight	= 2.07 kg/m
Alloy	EN AW-6063

Order data	Order number
Four sided softline extrusion 45x45	
Standard length 5000 mm	E10-1-5M
Four sided softline extrusion	
Cut to length	E10-1-02-02/...
Extra machining	<a href="#">Pages 24-46</a>

### Light extrusion 45x45 Type E02-1

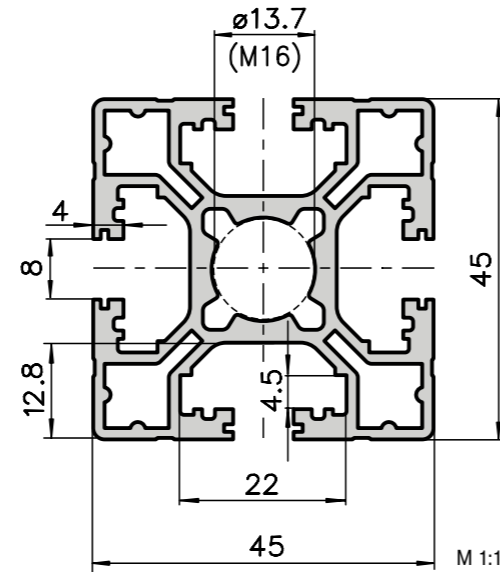

#### Application

With this light extrusion 45x45 you have many possible applications. The light-weight design offers a stable construction at an unbeatable price. This profile is particularly suitable for protective enclosures.

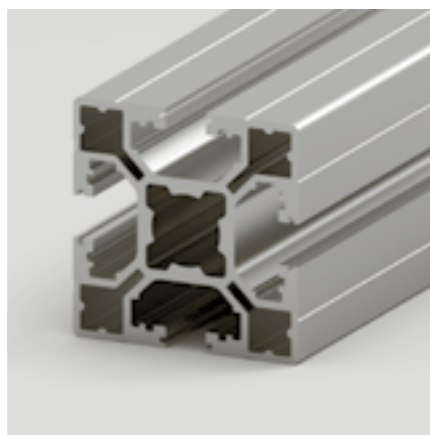

Technical data	
Ix, y	= 13.16 cm <sup>4</sup>
Wx, y	= 5.85 cm <sup>3</sup>
Cross-section area	= 6.37 cm <sup>2</sup>
Weight	= 1.72 kg/m
Alloy	EN AW-6063

Order data	Order number
Light extrusion 45x45	
Standard length 5000 mm	E02-1-5M
Light extrusion 45x45	
Cut to length	E02-1-02-02/...
Extra machining	<a href="#">Pages 24-46</a>

### Base extrusion 45x45 Type E01-1

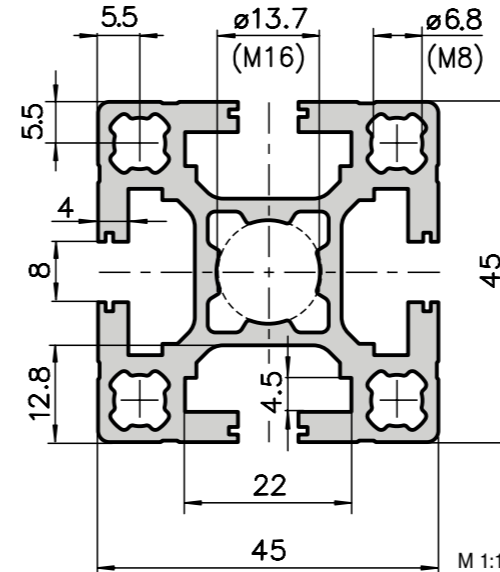

#### Application

The extrusions of base 45 are an ideal supplement to those of bases 20, 30, 40 and 50. The base extrusion 45x45 can be used for all types of constructions. It is exceptionally stable. It has an optimal weight and mechanical strength ratio.

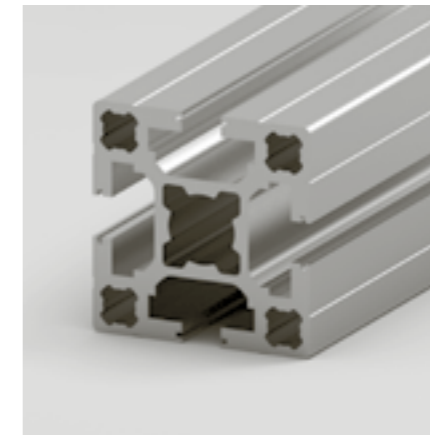

Technical data	
Ix, y	= 16.12 cm <sup>4</sup>
Wx, y	= 7.16 cm <sup>3</sup>
Cross-section area	= 7.68 cm <sup>2</sup>
Weight	= 2.07 kg/m
Alloy	EN AW-6063

Order data	Order number
Base extrusion 45x45	
Standard length 5000 mm	E01-1-5M
Base extrusion 45x45	
Cut to length	E01-1-02-02/...
Extra machining	<a href="#">Pages 24-46</a>

### Face extrusion 45x45 Type E02-6

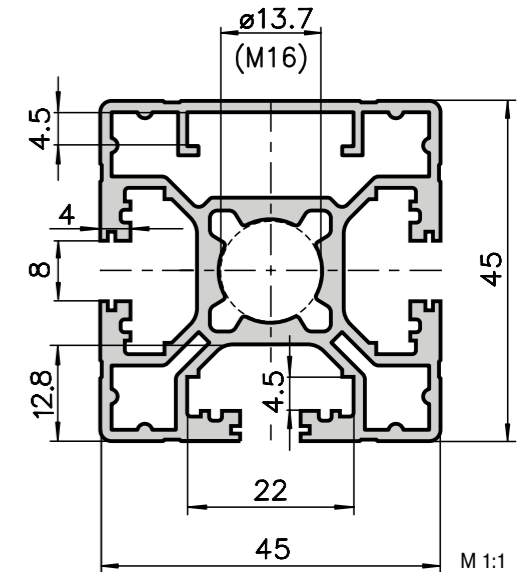

#### Application

As with the base extrusion, the face extrusion can also be used for a wide range of applications. They are distinguishable by having one closed side. This reduces possible dirt deposits and gives an optically smooth effect. Extrusions can also be fitted onto the closed faces.

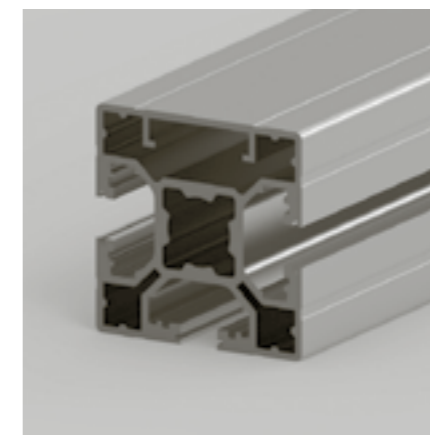

Technical data	
Ix	= 11.76 cm <sup>4</sup>
Iy	= 12.20 cm <sup>4</sup>
Wx	= 5.13 cm <sup>3</sup>
Wy	= 5.42 cm <sup>3</sup>
Cross-section area	= 5.77 cm <sup>2</sup>
Weight	= 1.59 kg/m
Alloy	EN AW-6063

Order data	Order number
Face extrusion 45x45	
Standard length 5000 mm	E02-6-5M
Face extrusion 45x45	
Cut to length	E02-6-02-02/...
Extra machining	<a href="#">Pages 24-46</a>

### Corner extrusion 45x45 Type E02-7

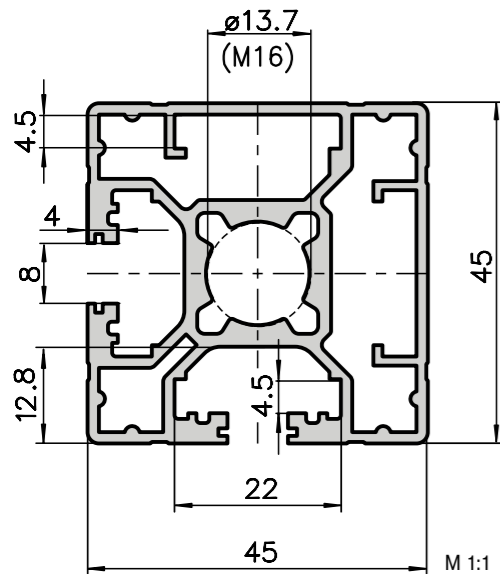

#### Application

Since it is closed on two sides, the corner extrusion has a compact appearance. This simplifies cleaning but it can still be used universally. Extrusions can also be fitted onto the closed faces.

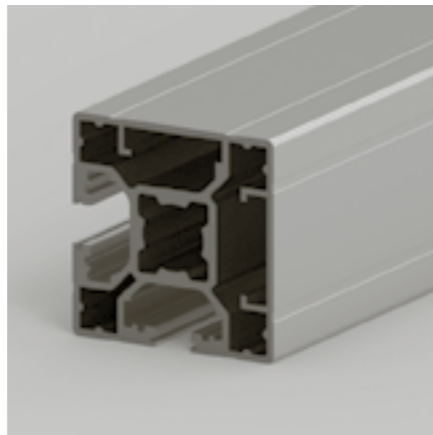

#### Technical data

I <sub>x</sub>	=	11.75 cm <sup>4</sup>
I <sub>y</sub>	=	11.83 cm <sup>4</sup>
W <sub>x</sub>	=	5.12 cm <sup>3</sup>
W <sub>y</sub>	=	5.16 cm <sup>3</sup>
Cross-section area	=	5.63 cm <sup>2</sup>
Weight	=	1.52 kg/m
Alloy	=	EN AW-6063

#### Order data

Order data	Order number
Corner extrusion 45x45	
Standard length 5000 mm	E02-7-5M
Corner extrusion 45x45	
Cut to length	E02-7-02-02/...

Extra machining [Pages 24-46](#)

### Double face extrusion 45x45 Type E02-4

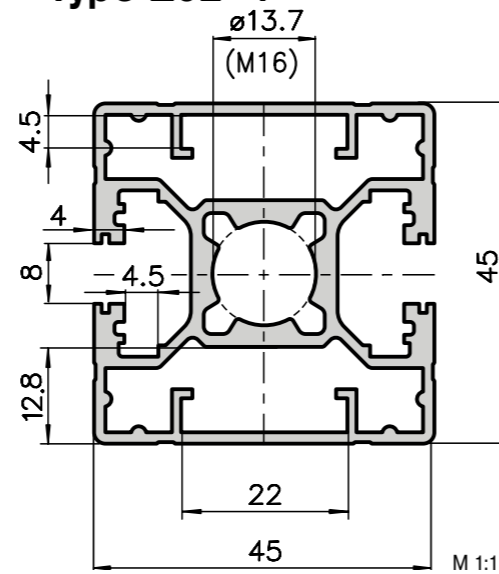

#### Application

The double face extrusion 45x45 lends itself for all types of cladding. The two closed profile fronts present a timeless design.

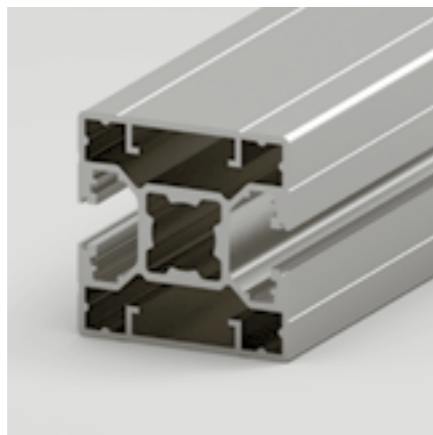

#### Technical data

I <sub>x</sub>	=	11.46 cm <sup>4</sup>
I <sub>y</sub>	=	12.33 cm <sup>4</sup>
W <sub>x</sub>	=	5.09 cm <sup>3</sup>
W <sub>y</sub>	=	5.48 cm <sup>3</sup>
Cross-section area	=	5.58 cm <sup>2</sup>
Weight	=	1.56 kg/m
Alloy	=	EN AW-6063

#### Order data

Order data	Order number
Double face extrusion 45x45	
Standard length 5000 mm	E02-4-5M
Double face extrusion 45x45	
Cut to length	E02-4-02-02/...

Extra machining [Pages 24-46](#)

### Softline extrusion 45x45 Type E03-1

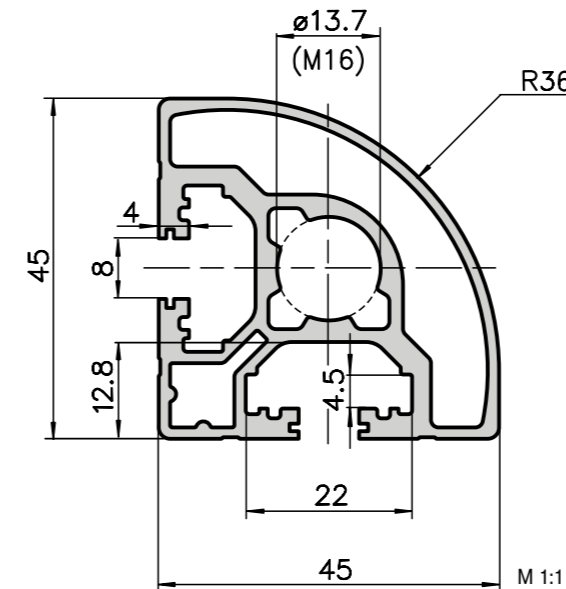

#### Application

The softline extrusion is suited for all applications where sharp corners are not desired. The round form has an elegant, modern and timeless effect. The profile is often used for construction of furniture and picture frames.

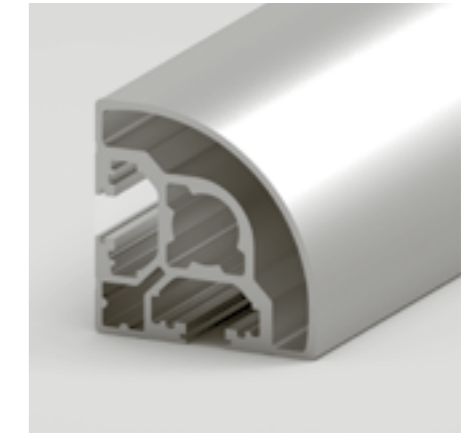

#### Technical data

I <sub>x, y</sub>	=	9.70 cm <sup>4</sup>
W <sub>x, y</sub>	=	3.80 cm <sup>3</sup>
Cross-section area	=	5.35 cm <sup>2</sup>
Weight	=	1.45 kg/m
Alloy	=	EN AW-6063

#### Order data

Order data	Order number
Softline extrusion 45x45	
Standard length 5000 mm	E03-1-5M
Softline extrusion 45x45	
Cut to length	E03-1-02-02/...

Extra machining [Pages 24-46](#)

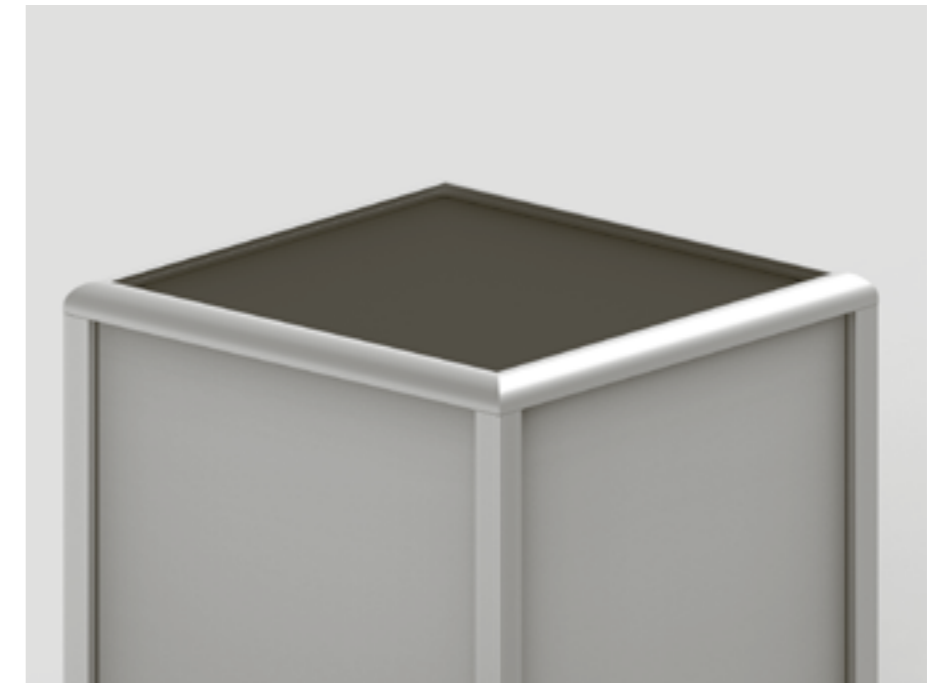

### Light extrusion 45x90 Type E02-3

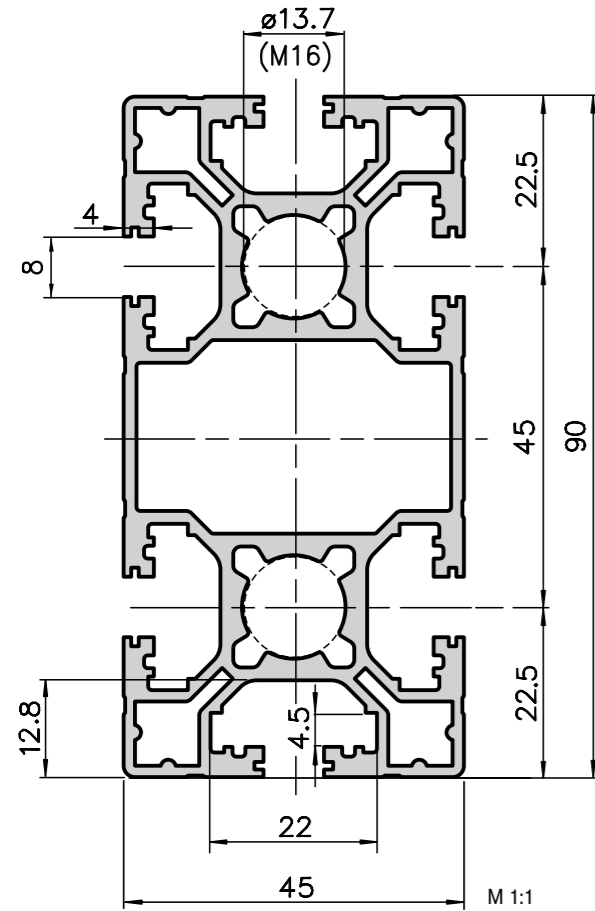

#### Application

This extrusion with 2 center holes increases the connection stability. The light-weight design offers a stable construction at an unbeatable price.

#### Technical data

$I_x$	=	90.44 cm <sup>4</sup>
$I_y$	=	23.62 cm <sup>4</sup>
$W_x$	=	20.10 cm <sup>3</sup>
$W_y$	=	10.50 cm <sup>3</sup>
Cross-section area	=	10.54 cm <sup>2</sup>
Weight	=	2.84 kg/m
Alloy	=	EN AW-6063

#### Order data

Order data	Order number
Light extrusion 45x90	
Standard length 5000 mm	E02-3-5M
Light extrusion 45x90	
Cut to length	E02-3-02-02/...
Extra machining	<a href="#">Pages 24-46</a>

### Base extrusion 45x90 Type E01-3

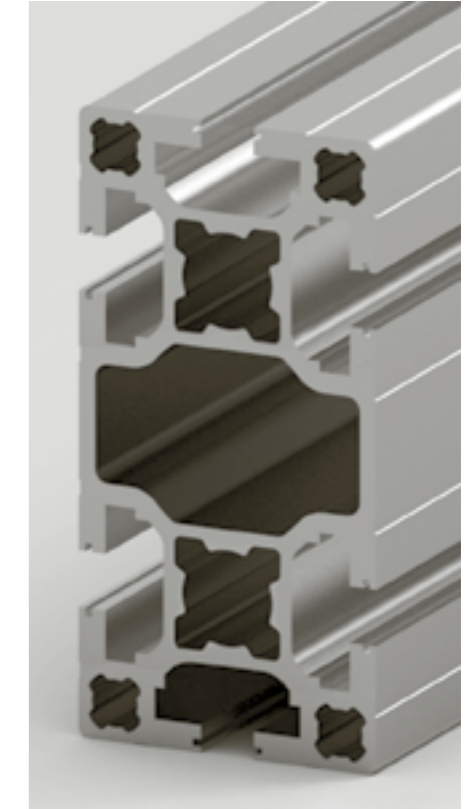
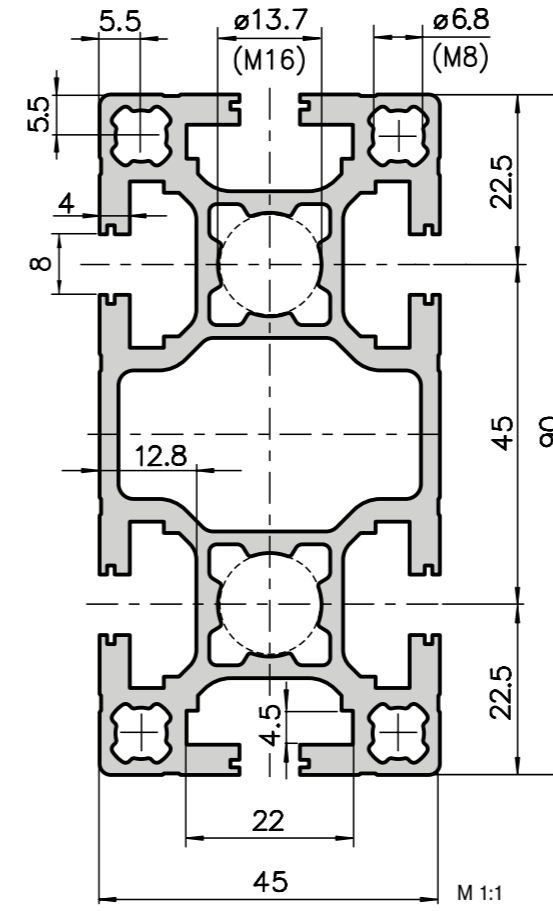

#### Application

This base extrusion can also be used for constructions of all types. It is exceptionally stable and its cross section makes a very wide range of applications possible.

#### Technical data

$I_x$	=	109.54 cm <sup>4</sup>
$I_y$	=	29.77 cm <sup>4</sup>
$W_x$	=	24.34 cm <sup>3</sup>
$W_y$	=	13.23 cm <sup>3</sup>
Cross-section area	=	12.97 cm <sup>2</sup>
Weight	=	3.50 kg/m
Alloy	=	EN AW-6063

#### Order data

Order data	Order number
Base extrusion 45x90	
Standard length 5000 mm	E01-3-5M
Base extrusion 45x90	
Cut to length	E01-3-02-02/...
Extra machining	<a href="#">Pages 24-46</a>

## Face extrusion 45x90 Type E01-14

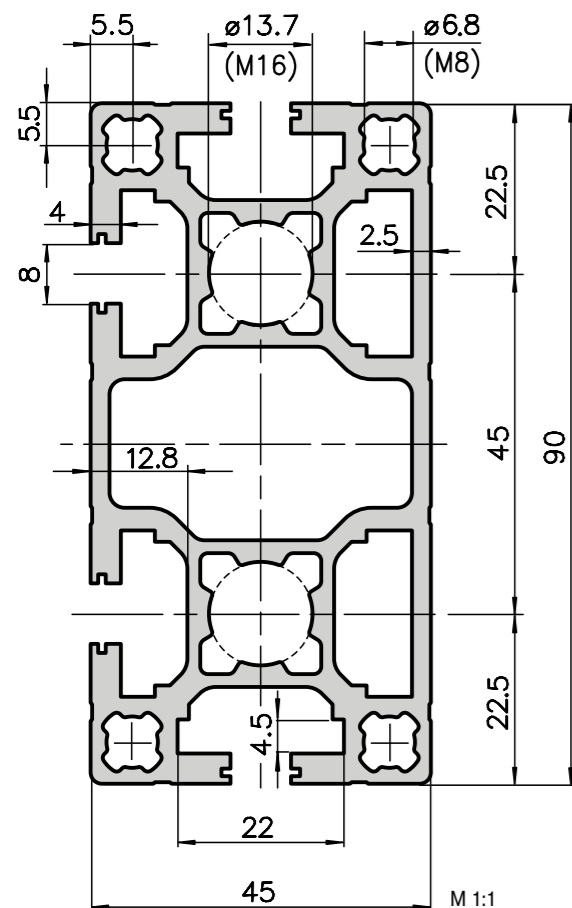

### Application

The closed sides reduce possible dirt deposits and give an optically smooth effect. As with all face extrusion, this can also be used for a wide range of applications. Extrusions can also be fitted onto the closed faces.

### Technical data

$I_x$	=	109.45 cm <sup>4</sup>
$I_y$	=	30.23 cm <sup>4</sup>
$W_x$	=	24.32 cm <sup>3</sup>
$W_y$	=	13.38 cm <sup>3</sup>
Cross-section area	=	12.99 cm <sup>2</sup>
Weight	=	3.50 kg/m
Alloy	=	EN AW-6063

### Order data

Order data	Order number
Face extrusion 45x90	
Standard length 5000 mm	E01-14-5M
Face extrusion 45x90	
Cut to length	E01-14-02-02/...
Extra machining	<a href="#">Pages 24-46</a>

## Corner extrusion 45x90 Type E02-2

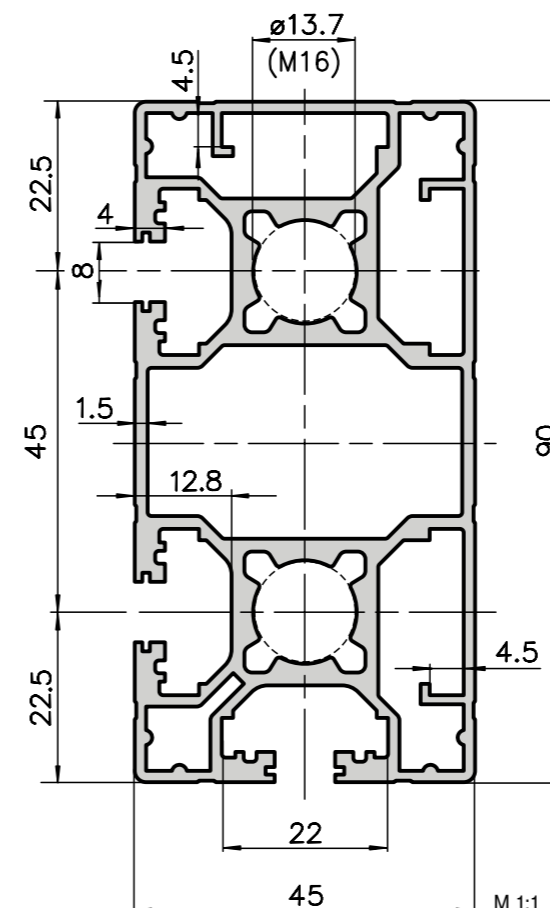

### Application

The corner extrusion is suitable for formwork of all types. The closed sides simplify cleaning. Extrusions can also be fitted onto the closed faces.

### Technical data

$I_x$	=	82.76 cm <sup>4</sup>
$I_y$	=	22.31 cm <sup>4</sup>
$W_x$	=	18.26 cm <sup>3</sup>
$W_y$	=	9.79 cm <sup>3</sup>
Cross-section area	=	9.80 cm <sup>2</sup>
Weight	=	2.65 kg/m
Alloy	=	EN AW-6063

### Order data

Order data	Order number
Corner extrusion 45x90	
Standard length 5000 mm	E02-2-5M
Corner extrusion 45x90	
Cut to length	E02-2-02-02/...
Extra machining	<a href="#">Pages 24-46</a>



### Beam extrusion 45x135 Type E01-19

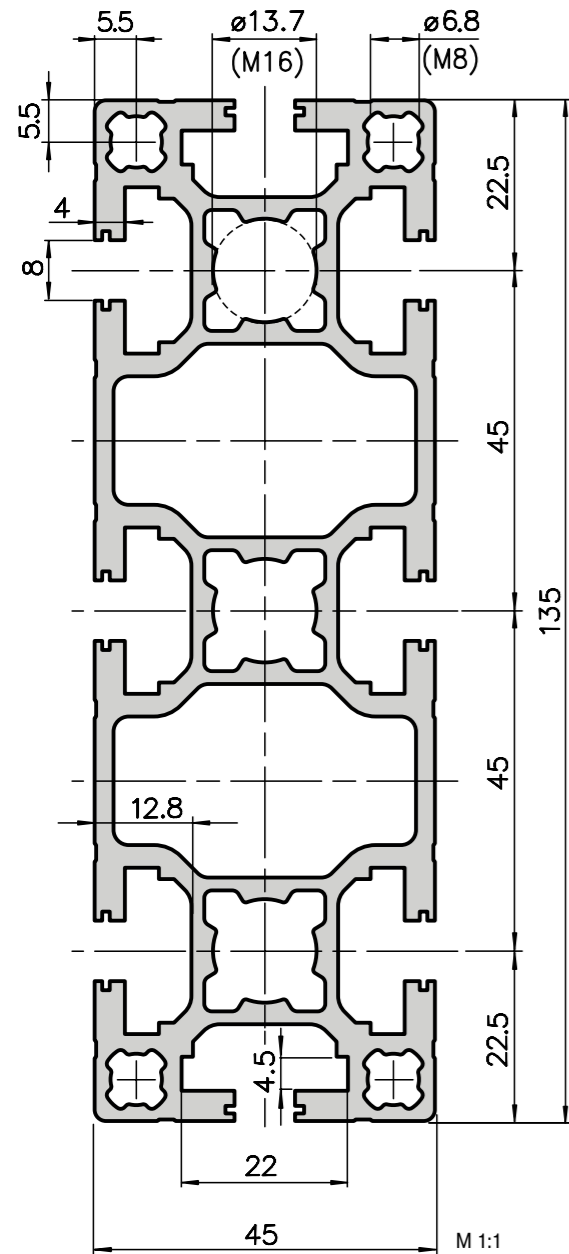

#### Application

This beam extrusion is mainly used for high loads, thanks to its excellent mechanical strength properties.

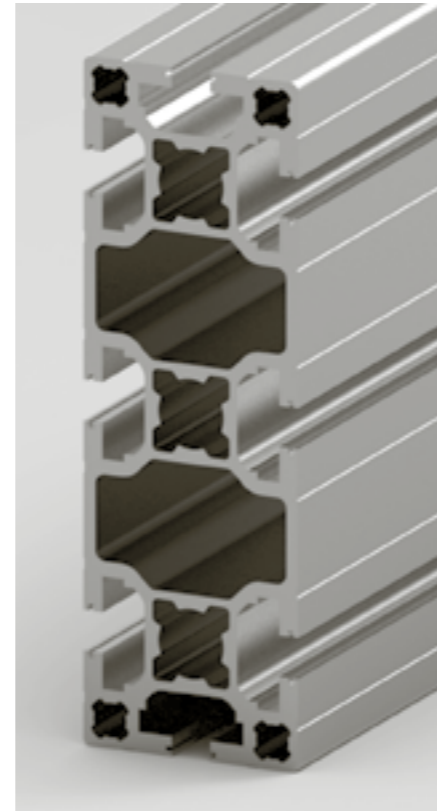

#### Technical data

$I_x$	=	334.22 cm <sup>4</sup>
$I_y$	=	43.41 cm <sup>4</sup>
$W_x$	=	49.51 cm <sup>3</sup>
$W_y$	=	19.30 cm <sup>3</sup>
Cross-section area	=	18.25 cm <sup>2</sup>
Weight	=	4.93 kg/m
Alloy	=	EN AW-6063

#### Order data

Order data	Order number
Beam extrusion 45x135	
Standard length 6000 mm	E01-19-6M
Beam extrusion 45x135	
Cut to length	E01-19-02-02/...
Extra machining	<a href="#">Pages 24-46</a>

### Beam extrusion 45x180 Type E01-16

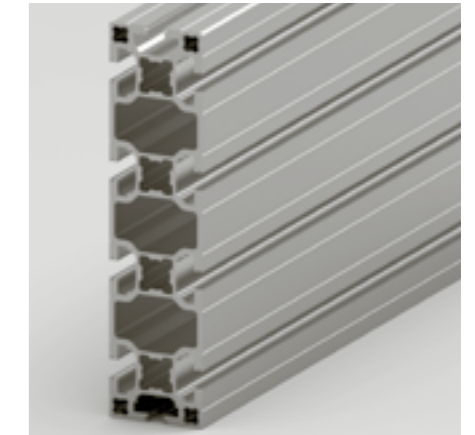
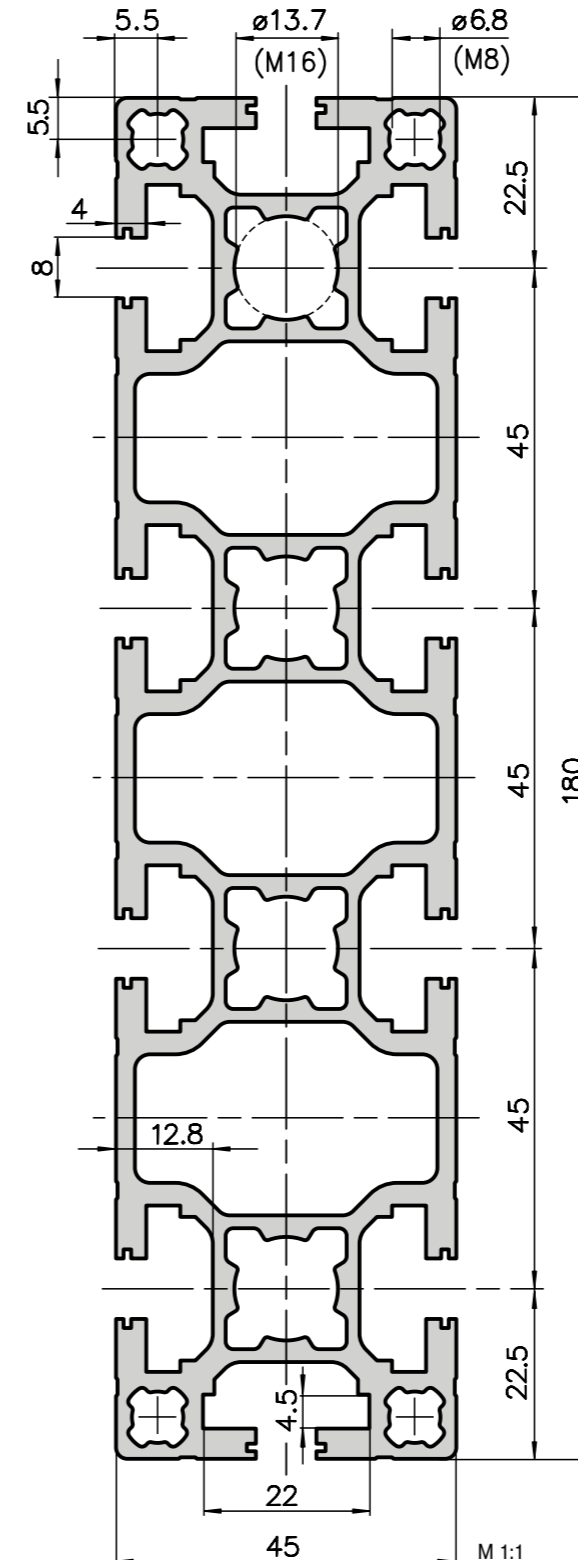

#### Application

A extrusion for applications with very high load and span widths. Robust large structures can be built. It is also the perfect solution for large portals and stable cross beams.

#### Technical data

$I_x$	=	743.74 cm <sup>4</sup>
$I_y$	=	57.06 cm <sup>4</sup>
$W_x$	=	82.64 cm <sup>3</sup>
$W_y$	=	25.36 cm <sup>3</sup>
Cross-section area	=	23.54 cm <sup>2</sup>
Weight	=	6.36 kg/m
Alloy	=	EN AW-6063

#### Order data

Order data	Order number
Beam extrusion 45x180	
Standard length 6000 mm	E01-16-6M
Beam extrusion 45x180	
Cut to length	E01-16-02-02/...
Extra machining	<a href="#">Pages 24-46</a>

### Light extrusion 90x90 Type E02-5

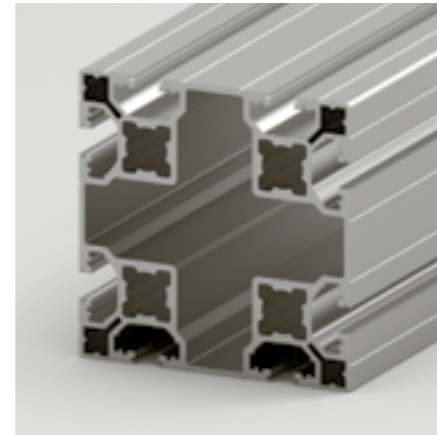
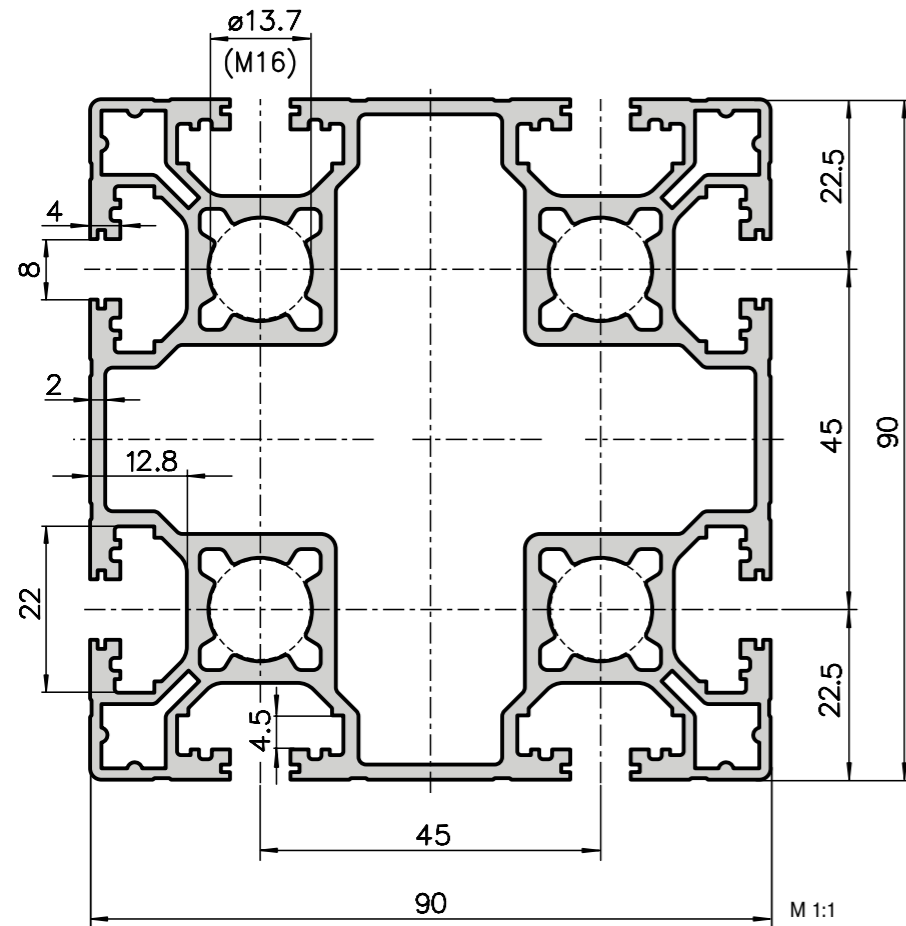

#### Application

The light extrusion 90x90 main feature is its optimal torsional stiffness. The lightweight design offers a stable construction at an unbeatable price.

Technical data	
$I_{x, y}$	= 160.09 cm <sup>4</sup>
$W_{x, y}$	= 35.58 cm <sup>3</sup>
Cross-section area	= 17.53 cm <sup>2</sup>
Weight	= 4.73 kg/m
Alloy	EN AW-6063

Order data	Order number
Light extrusion 90x90	
Standard length 6000 mm	E02-5-6M
Light extrusion 90x90	
Cut to length	E02-5-02-02/...
Extra machining	<a href="#">Pages 24-46</a>

### Base extrusion 90x90 Type E01-4

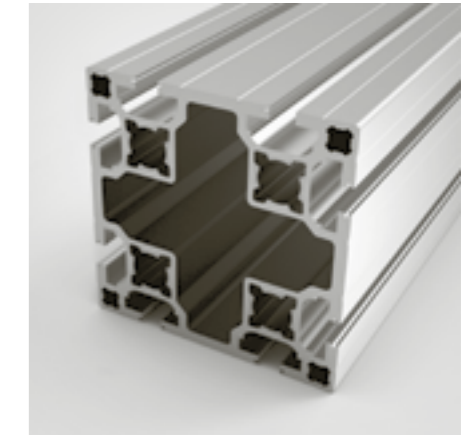
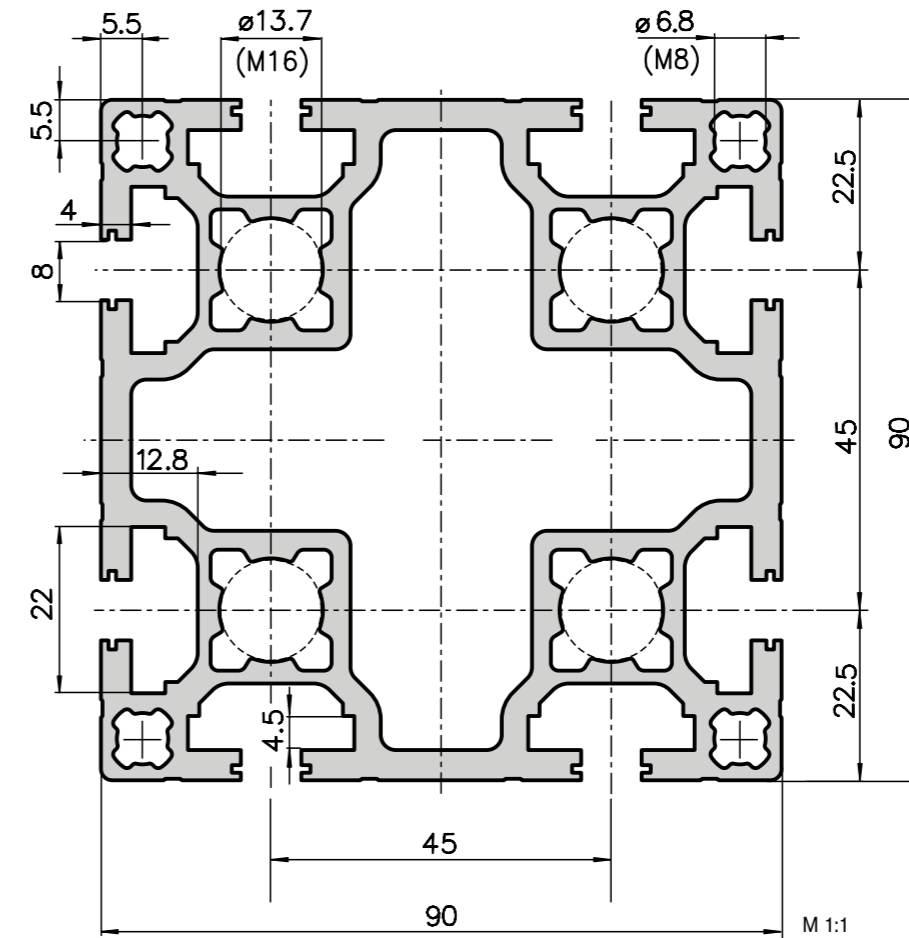

#### Application

The qualities of this universal extrusion are its high strength and torsional stiffness. These make it widely used in mechanical and plant engineering. Let your ideas run free.

Technical data	
$I_{x, y}$	= 205.78 cm <sup>4</sup>
$W_{x, y}$	= 45.73 cm <sup>3</sup>
Cross-section area	= 22.50 cm <sup>2</sup>
Weight	= 6.08 kg/m
Alloy	EN AW-6063

Order data	Order number
Base extrusion 90x90	
Standard length 6000 mm	E01-4-6M
Base extrusion 90x90	
Cut to length	E01-4-02-02/...
Extra machining	<a href="#">Pages 24-46</a>

### Beam extrusion 90x135 Type E01-13

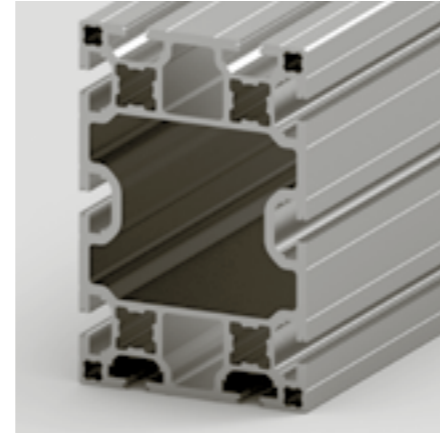
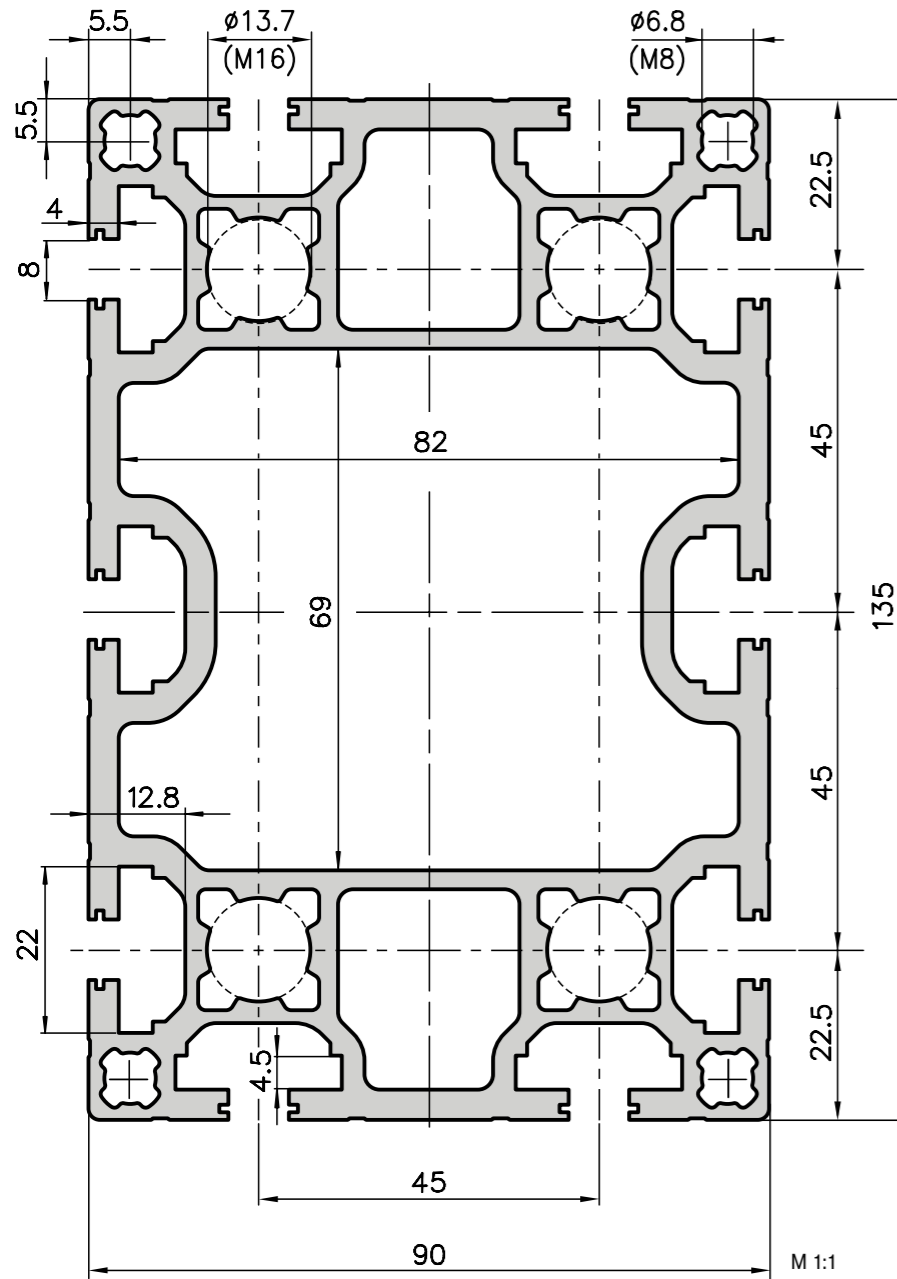

**Application**

This extrusion can be used for a wide range of applications. Its optimal structural stress values make it perfect for general constructions with high loads.

**Technical data**

$I_x$	=	618.00 cm <sup>4</sup>
$I_y$	=	300.57 cm <sup>4</sup>
$W_x$	=	98.56 cm <sup>3</sup>
$W_y$	=	66.79 cm <sup>3</sup>
Cross-section area	=	30.06 cm <sup>2</sup>
Weight	=	8.10 kg/m
Alloy	=	EN AW-6063

**Order data**      **Order number**

Beam extrusion 90x135	
Standard length 6000 mm	E01-13-6M
Beam extrusion 90x135	
Cut to length	E01-13-02-02/...

Extra machining      [Pages 24-46](#)

### Beam extrusion 90x180 Type E01-5

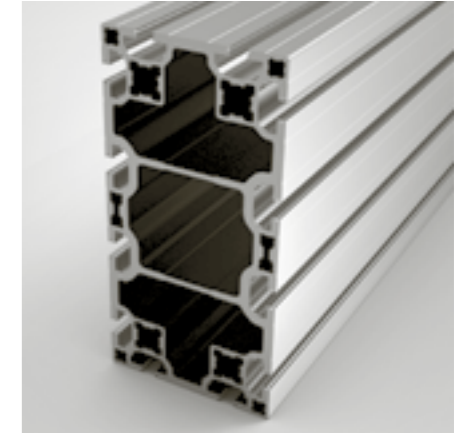
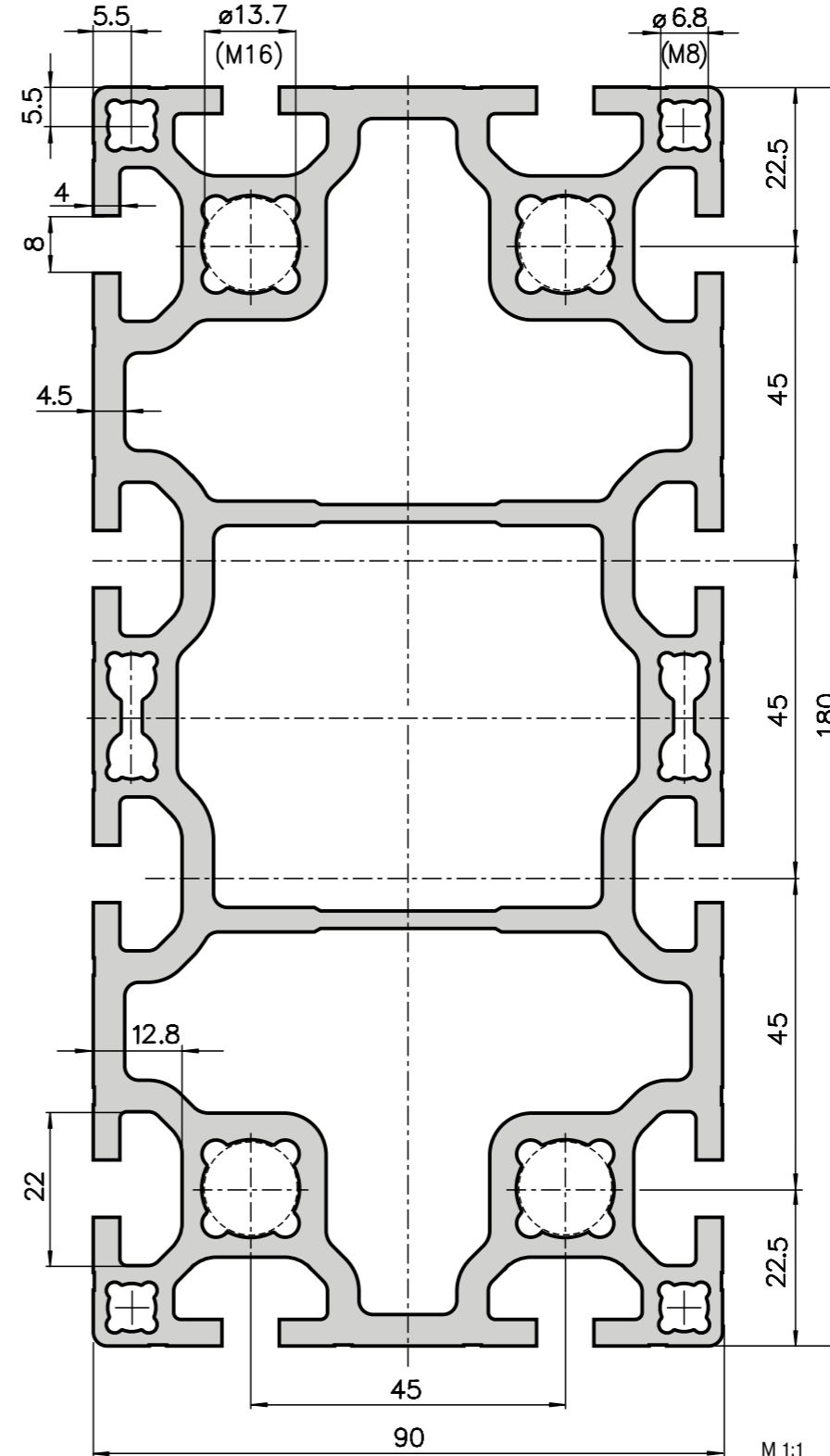

**Application**

A heavy duty extrusion for portal construction and structures with large self supporting lengths. Ideally suited for all large structures.

**Technical data**

$I_x$	=	1525.63 cm <sup>4</sup>
$I_y$	=	443.9 cm <sup>4</sup>
$W_x$	=	169.51 cm <sup>3</sup>
$W_y$	=	98.64 cm <sup>3</sup>
Cross-section area	=	44.68 cm <sup>2</sup>
Weight	=	12.06 kg/m
Alloy	=	EN AW-6063

**Order data**      **Order number**

Beam extrusion 90x180	
Standard length 6000 mm	E01-5-6M
Beam extrusion 90x180	
Cut to length	E01-5-02-02/...

Extra machining      [Pages 24-46](#)

### Four sided softline extrusion 40x40 type C10-0

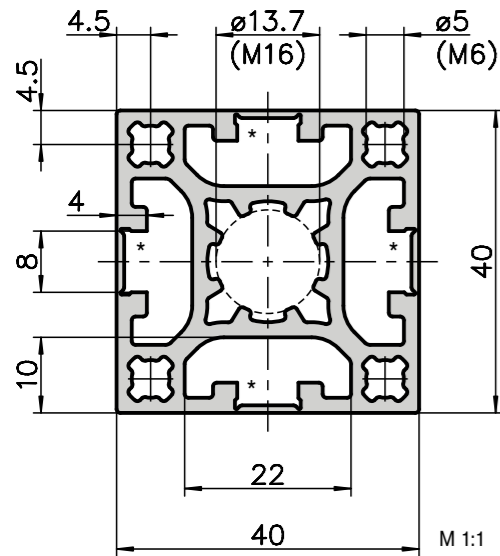

\* Rip off slot

#### Application

These extrusions are used in clean-room applications, in the food industry or anywhere where no open slots are to be found and where smooth surfaces are desired. Thanks to the rip off slots, all connection options are guaranteed.

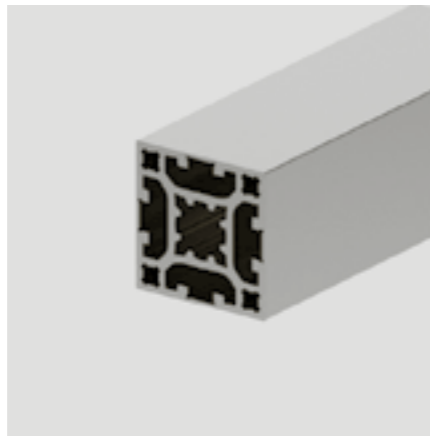

### Four sided softline extrusion 40x80 type C10-3

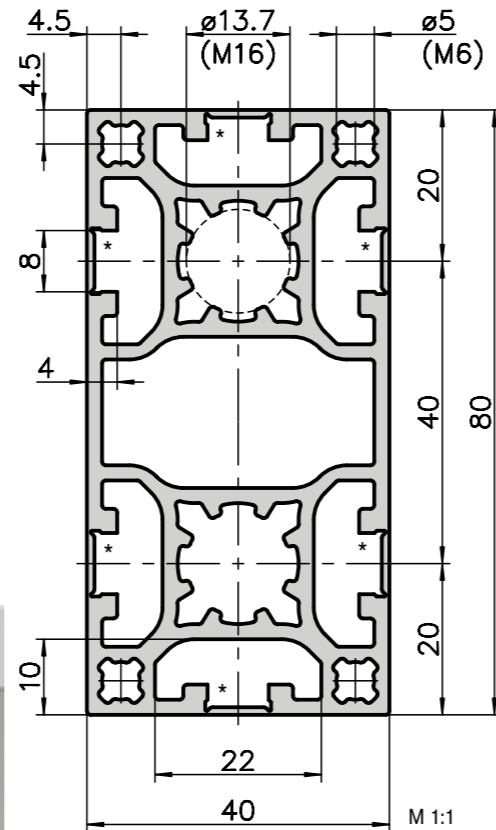

#### Application

Due to its dimensions, this extrusion achieves high stability and is mostly used in clean room areas or in the food industry.

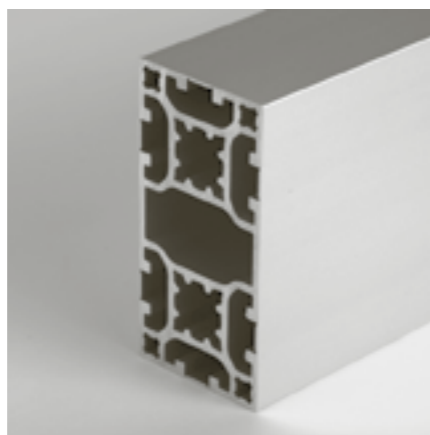

#### Technical data

$I_{x,y}$	=	69.73 cm <sup>4</sup>
$I_y$	=	18.52 cm <sup>4</sup>
$W_x$	=	17.43 cm <sup>3</sup>
$W_y$	=	9.26 cm <sup>3</sup>
Cross-section area	=	10.34 cm <sup>2</sup>
Weight	=	2.8 kg/m
Alloy	=	EN AW-6060

#### Order data

Four sided softline extrusion 40x80	Standard length 5000 mm	C10-3-5M
Four sided softline extrusion 40x80	Cut to length	C10-3-02-02/...

### Four sided softline extrusion 80x80 type C10-4

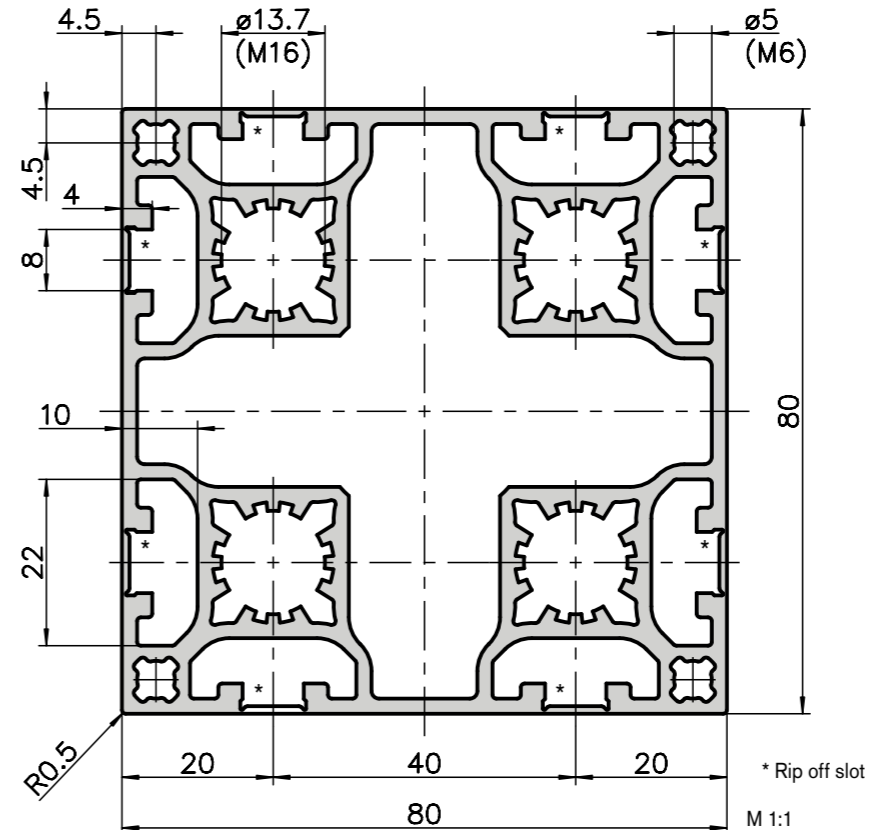

\* Rip off slot

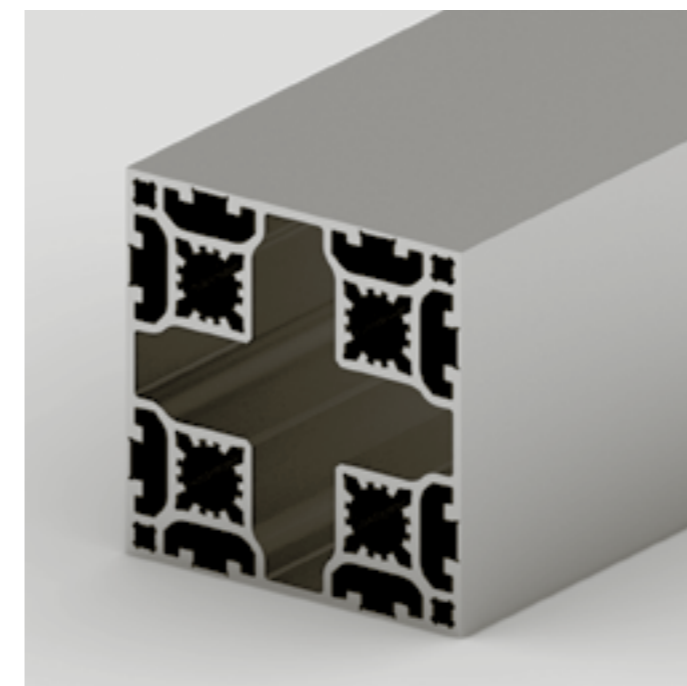

#### Application

This lightweight, fully closed extrusion with a dimension 80x80, together with the 40x40 and 40x80 of the softline range of extrusions, is used in clean-room applications and for aesthetic applications where no slots are desired. The slots can be easily opened thanks to the predetermined breaking point. The proven Kanya connection technology can be easily used. Closing slots afterwards is inefficient and expensive! Partial opening of slots does not pose a problem, thereby allowing panels to be inserted into the slots of constructions.

#### Technical data

$I_{x,y}$	=	119.40 cm <sup>4</sup>
$W_{x,y}$	=	29.85 cm <sup>3</sup>
Cross-section area	=	16.36 cm <sup>2</sup>
Weight	=	4.39 kg/m
Alloy	=	EN AW-6060

#### Order data

Softline extrusion 80x80	Standard length 5000 mm	C10-4-5M
Softline extrusion 80x80	Cut to length	C10-4-02-02/...
Extra machining		<a href="#">Pages 24-46</a>

#### Technical data

$I_{x,y}$	=	9.6 cm <sup>4</sup>
$W_{x,y}$	=	4.75 cm <sup>3</sup>
Cross-section area	=	5.97 cm <sup>2</sup>
Weight	=	1.6 kg/m
Alloy	=	EN AW-6060

#### Order data

Four sided softline extrusion 40x40	Standard length 5000 mm	C10-0-5M
Four sided softline extrusion 40x40	Cut to length	C10-0-02-02/...
Extra machining		<a href="#">Pages 24-46</a>

Extra machining

[Pages 24-46](#)

### 40x40 super lightweight extrusion type C03-1

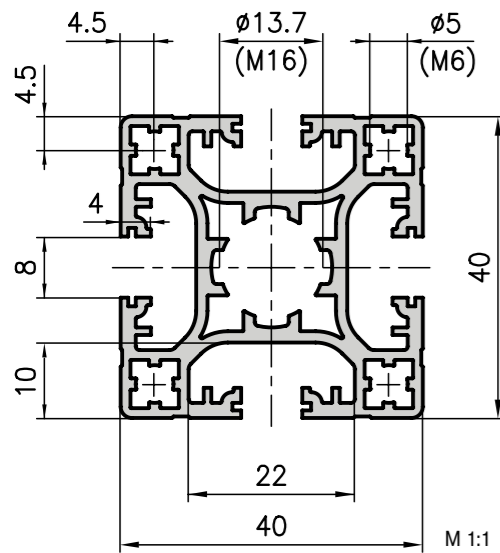

### 40x40 lightweight extrusion type C02-1

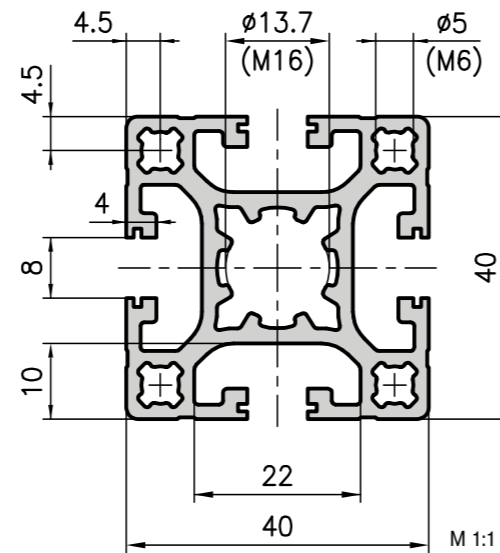

### 40x40 base extrusion type C01-1

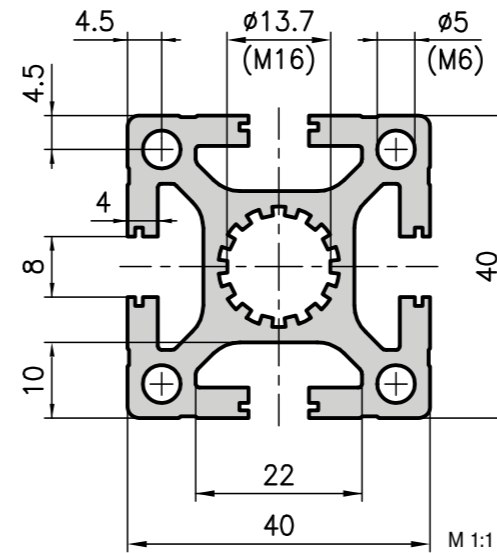

### 40x40 face extrusion type C01-8

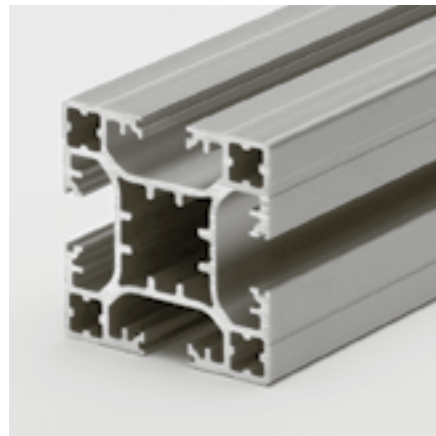
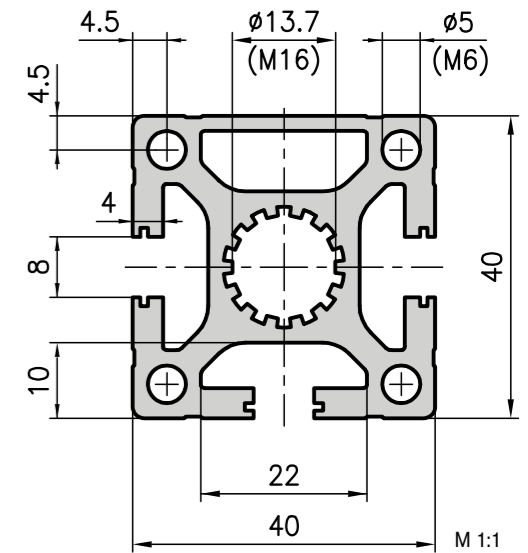

#### Application

These lightweight extrusions help to keep costs down! They can be used to create lightweight designs with excellent loadbearing capabilities.



#### Technical data

$I_{x,y}$	=	8.20 cm <sup>4</sup>
$W_{x,y}$	=	4.10 cm <sup>3</sup>
Cross-section area	=	4.90 cm <sup>2</sup>
Weight	=	1.3 kg/m
Alloy	=	EN AW-6060

#### Order data Order number

40x40 super lightweight extrusion	
Standard length 5000 mm	C03-1-5M
40x40 super lightweight extrusion	
Cut to length	C03-1-02-02/...
Extra machining	<a href="#">Pages 24-46</a>

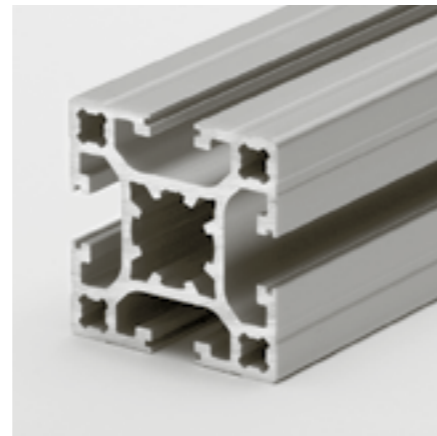

#### Technical data

$I_{x,y}$	=	9.35 cm <sup>4</sup>
$W_{x,y}$	=	4.67 cm <sup>3</sup>
Cross-section area	=	5.70 cm <sup>2</sup>
Weight	=	1.5 kg/m
Alloy	=	EN AW-6063

#### Order data Order number

40x40 lightweight extrusion	
Standard length 5000 mm	C02-1-5M
40x40 lightweight extrusion	
Cut to length	C02-1-02-02/...
Extra machining	<a href="#">Pages 24-46</a>

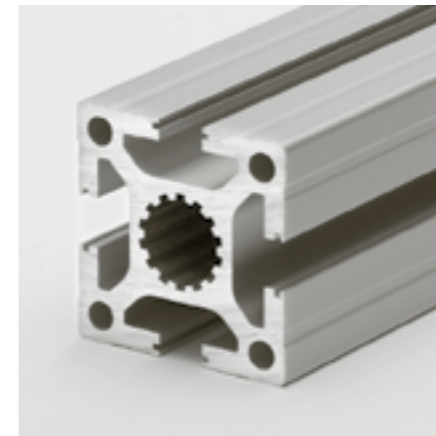

#### Technical data

$I_{x,y}$	=	11.70 cm <sup>4</sup>
$W_{x,y}$	=	5.75 cm <sup>3</sup>
Cross-section area	=	7.29 cm <sup>2</sup>
Weight	=	2.0 kg/m
Alloy	=	EN AW-6063

#### Order data Order number

40x40 base extrusion	
Standard length 5000 mm	C01-1-5M
40x40 base extrusion	
Cut to length	C01-1-02-02/...
Extra machining	<a href="#">Pages 24-46</a>

#### Application

These versatile extrusions can be used for all kinds of structures. With their 40 mm base, they complement extrusions with 20, 30 and 50 mm bases perfectly. The base extrusion itself is extraordinarily sturdy and is hard to beat in terms of value for money.



Extra machining

[Pages 24-46](#)

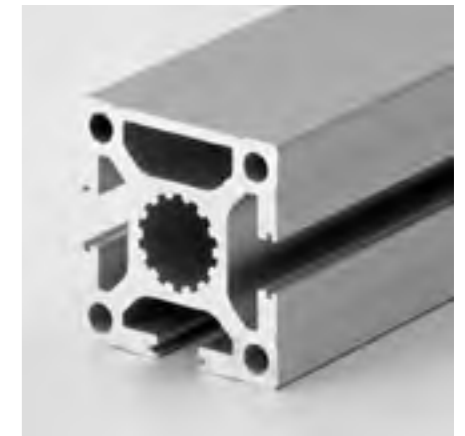

#### Technical data

$I_x$	=	11.66 cm <sup>4</sup>
$I_y$	=	11.67 cm <sup>4</sup>
$W_x$	=	5.78 cm <sup>3</sup>
$W_y$	=	5.83 cm <sup>3</sup>
Cross-section area	=	7.30 cm <sup>2</sup>
Weight	=	2.0 kg/m
Alloy	=	EN AW-6063

#### Order data Order number

40x40 face extrusion	
Standard length 5000 mm	C01-8-5M
40x40 face extrusion	
Cut to length	C01-8-02-02/...

### 40x40 corner extrusion type C01-7

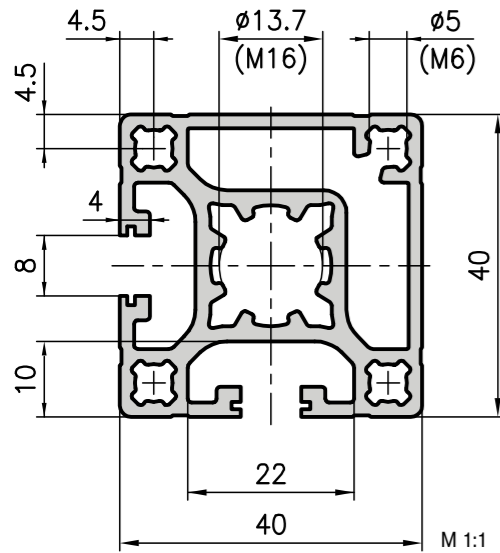

### 40x40 double face extrusion type C02-4

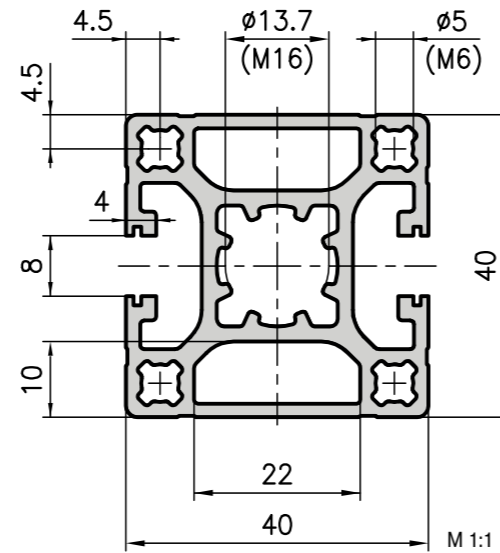

### Face panel extrusion 40x40 type C04-2

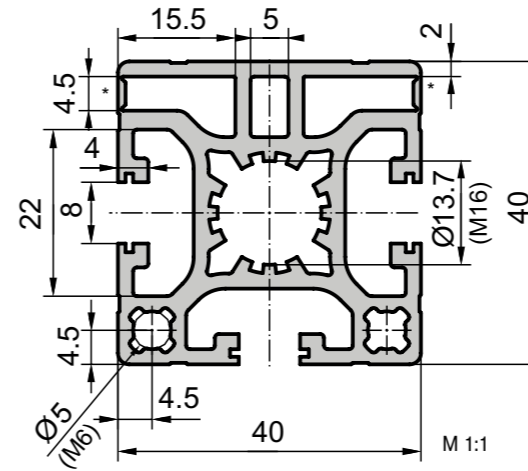

\* Rip off slot

### Corner panel extrusion 40x40 type C04-7

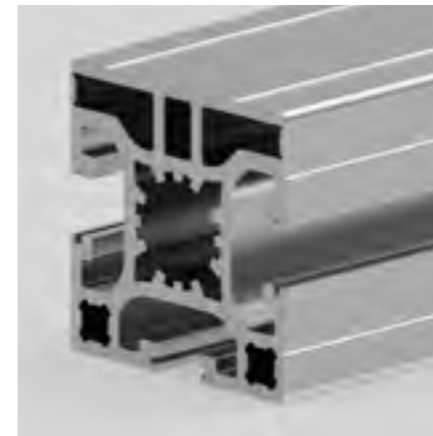
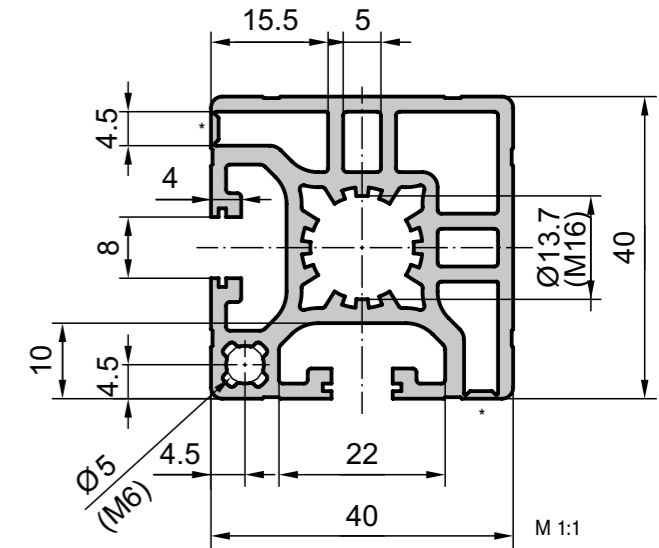

#### Application

Face and corner panel extrusions have rip off slots. This allows you to insert panels in the face extension. The associated surround extrusion C39-64 can be found on [Page 98](#).



#### Application

Partially closed extrusions are particularly attractive in design, trap less dirt and can be used for a wide range of applications.

#### Application

For all types of enclosure, as well as for structures with extrusion faces which are mainly closed and for applications with an attractive design.

#### Technical data

$I_{x,y}$	=	9.21 cm <sup>4</sup>
$W_{x,y}$	=	4.53 cm <sup>3</sup>
Cross-section area	=	5.56 cm <sup>2</sup>
Weight	=	1.5 kg/m
Alloy	=	EN AW-6063

#### Technical data

$I_x$	=	9.56 cm <sup>4</sup>
$I_y$	=	9.21 cm <sup>4</sup>
$W_x$	=	4.78 cm <sup>3</sup>
$W_y$	=	4.60 cm <sup>3</sup>
Cross-section area	=	5.69 cm <sup>2</sup>
Weight	=	1.5 kg/m
Alloy	=	EN AW-6063

#### Technical data

$I_x$	=	9.13 cm <sup>4</sup>
$I_y$	=	9.92 cm <sup>4</sup>
$W_x$	=	4.57 cm <sup>3</sup>
$W_y$	=	4.96 cm <sup>3</sup>
Cross-section area	=	60.25 cm <sup>2</sup>
Weight	=	1.63 kg/m
Alloy	=	EN AW-6063

#### Technical data

$I_x, y$	=	9.53 cm <sup>4</sup>
$W_x, y$	=	4.76 cm <sup>3</sup>
Cross-section area	=	60.87 cm <sup>2</sup>
Weight	=	1.64 kg/m
Alloy	=	EN AW-6063

#### Order data Order number

40x40 corner extrusion  
Standard length 5000 mm C01-7-5M

40x40 corner extrusion  
Cut to length C01-7-02-02/...

Extra machining

[Pages 24-46](#)

#### Order data Order number

40x40 double face extrusion  
Standard length 5000 mm C02-4-5M

40x40 double face extrusion  
Cut to length C02-4-02-02/...

#### Order data Order number

Face panel extrusion 40x40  
Standard length 5000 mm C04-2-5M

Face panel extrusion 40x40  
Cut to length C04-2-02-02/...



Extra machining

[Pages 24-46](#)

#### Order data Order number

Corner panel extrusion 40x40  
Standard length 5000 mm C04-7-5M

Corner panel extrusion 40x40  
Cut to length C04-7-02-02/...

Extra machining

[Pages 24-46](#)

### 45° angle extrusion type C04-4

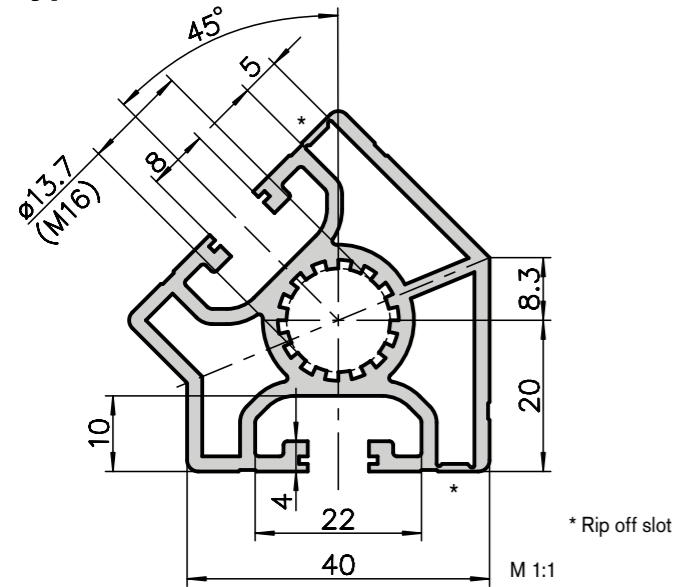

### 40x45° angle extrusion type C02-8

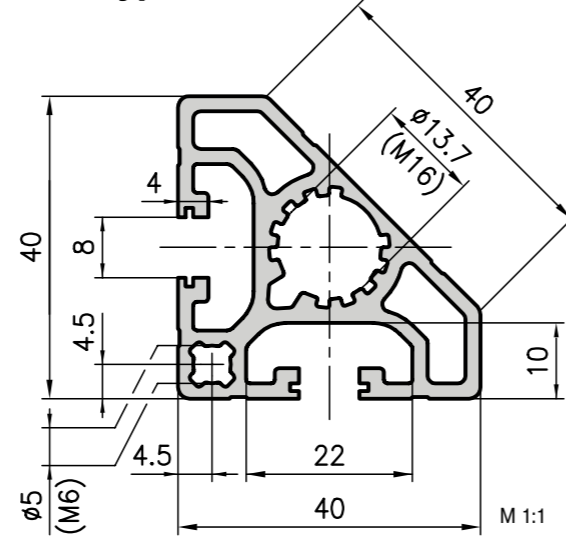

### Softline extrusion 40x40 type C03-8

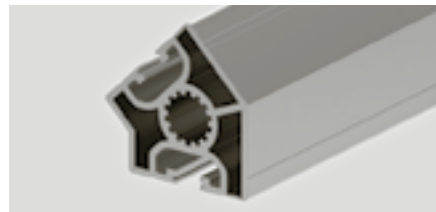
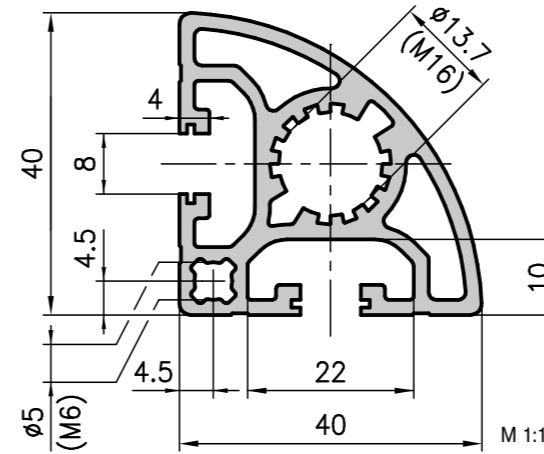

#### Application

The C02-8 type angle extrusion allows you to create attractive, soft contours and has the versatility to be used for all sorts of structural designs.

#### Technical data

$I_{x,y}$	=	6.30 cm <sup>4</sup>
$W_{x,y}$	=	2.70 cm <sup>3</sup>
Cross-section area	=	4.57 cm <sup>2</sup>
Weight	=	1.2 kg/m
Alloy	=	EN AW-6063

#### Order data      Order number

40x45° angle extrusion	
Standard length 5000 mm	C02-8-5M
40x45° angle extrusion	
Cut to length	C02-8-02-02/...
Extra machining	<a href="#">Pages 24-46</a>

#### Application

The softline extrusion is ideal for work tables, furniture, showcases, picture frames and much more. Everywhere where disturbing edges are undesirable.

#### Technical data

$I_{x,y}$	=	6.70 cm <sup>4</sup>
$W_{x,y}$	=	2.97 cm <sup>3</sup>
Cross-section area	=	4.90 cm <sup>2</sup>
Weight	=	1.3 kg/m
Alloy	=	EN AW-6060

#### Order data      Order number

Softline extrusion 40x40	
Standard length 5000 mm	C03-8-5M
Softline extrusion 40x40	
Cut to length	C03-8-02-02/...
Extra machining	<a href="#">Pages 24-46</a>



#### Application

Used for mitered constructions or as angle element for 45° connections.

#### Technical data

$I_x$	=	8.46 cm <sup>4</sup>
$I_y$	=	9.11 cm <sup>4</sup>
$W_x$	=	3.01 cm <sup>3</sup>
$W_y$	=	3.44 cm <sup>3</sup>
Cross-section area	=	5.52 cm <sup>2</sup>
Weight	=	1.49 kg/m
Alloy	=	EN AW-6060

#### Order data      Order number

45° angle extrusion	
Standard length 5000 mm	C04-4-5M
45° angle extrusion	
Cut to length	C04-4-02-02/...



Extra machining

[Pages 24-46](#)

### 40x80 light extrusion type C02-3

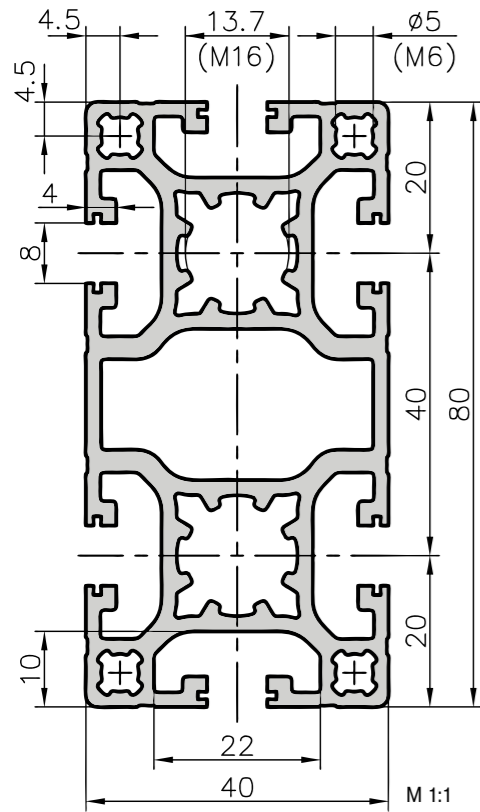

#### Application

These extrusions can be used to hold liquids and gases, to bear loads, to take threads and lots more. They can be a perfect solution to very specific problems. They can be combined with 20, 30, 45 and 50 series extrusions, which means that you can genuinely build on this design of extrusion.

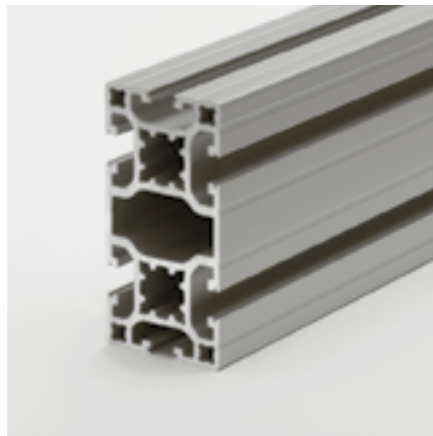

### 40x80 base extrusion type C01-3

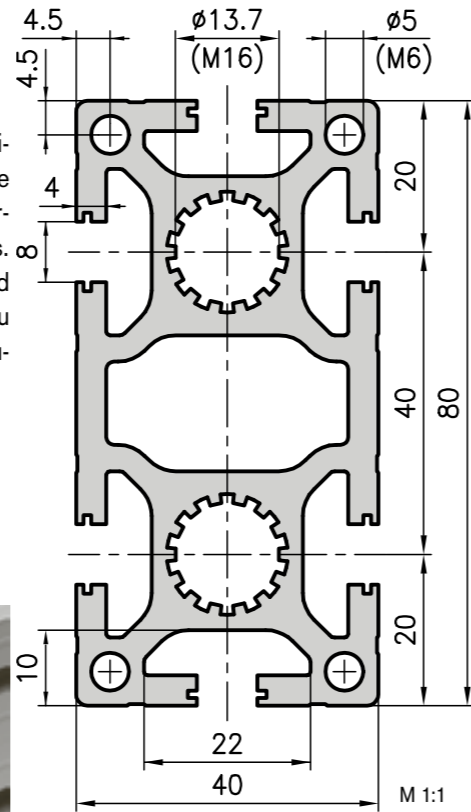

#### Technical data

Ix	=	81.95 cm <sup>4</sup>
Iy	=	22.74 cm <sup>4</sup>
Wx	=	20.49 cm <sup>3</sup>
Wy	=	11.37 cm <sup>3</sup>
Cross-section area	=	13.50 cm <sup>2</sup>
Weight	=	3.7 kg/m
Alloy	=	EN AW-6063

#### Order data

Order data	Order number
40x80 base extrusion Standard length 5000 mm	C01-3-5M
40x80 base extrusion Cut to length	C01-3-02-02/...

Extra machining [Pages 24-46](#)

### 40x80 face extrusion type C01-5

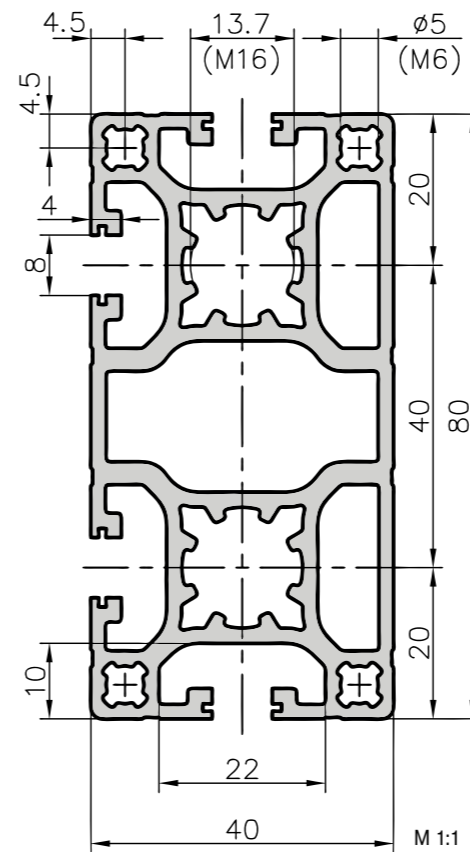

#### Application

Like all partially closed extrusions, this item is ideal if you want to keep your structure as clean as possible.

#### Technical data

Ix	=	64.40 cm <sup>4</sup>
Iy	=	17.20 cm <sup>4</sup>
Wx	=	16.10 cm <sup>3</sup>
Wy	=	8.60 cm <sup>3</sup>
Cross-section area	=	9.76 cm <sup>2</sup>
Weight	=	2.6 kg/m
Alloy	=	EN AW-6063

#### Order data

Order data	Order number
40x80 face extrusion Standard length 5000 mm	C01-5-5M
40x80 face extrusion Cut to length	C01-5-02-02/...
Extra machining	<a href="#">Pages 24-46</a>

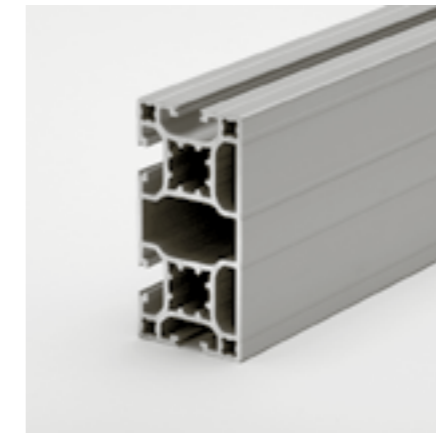

#### Application

The light extrusion 40x120 is used as a cost efficient beam.

#### Technical data

Ix	=	203.49 cm <sup>4</sup>
Iy	=	25.75 cm <sup>4</sup>
Wx	=	33.91 cm <sup>3</sup>
Wy	=	12.87 cm <sup>3</sup>
Cross-section area	=	14.77 cm <sup>2</sup>
Weight	=	3.99 kg/m
Alloy	=	EN AW-6060

#### Order data

Order data	Order number
40x120 light extrusion Standard length 5000 mm	C03-9-5M
40x120 light extrusion Cut to length	C03-9-02-02/...
Extra machining	<a href="#">Pages 24-46</a>

### 40x120 light extrusion type C03-9

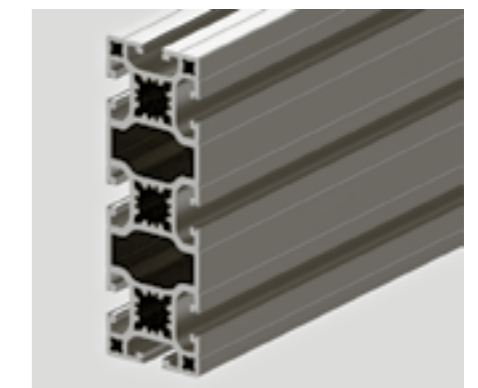
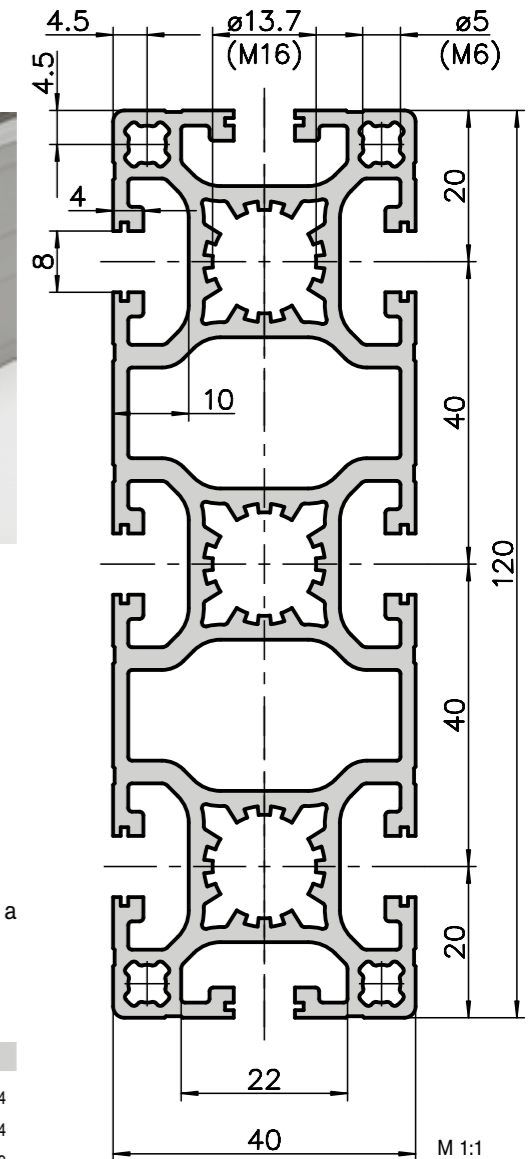

#### Technical data

Ix	=	64.90 cm <sup>4</sup>
Iy	=	17.70 cm <sup>4</sup>
Wx	=	16.23 cm <sup>3</sup>
Wy	=	8.85 cm <sup>3</sup>
Cross-section area	=	10.20 cm <sup>2</sup>
Weight	=	2.8 kg/m
Alloy	=	EN AW-6063

#### Order data

Order data	Order number
40x80 light extrusion Standard length 5000 mm	C02-3-5M
40x80 light extrusion Cut to length	C02-3-02-02/...



### 40x120 beam extrusion type C01-9

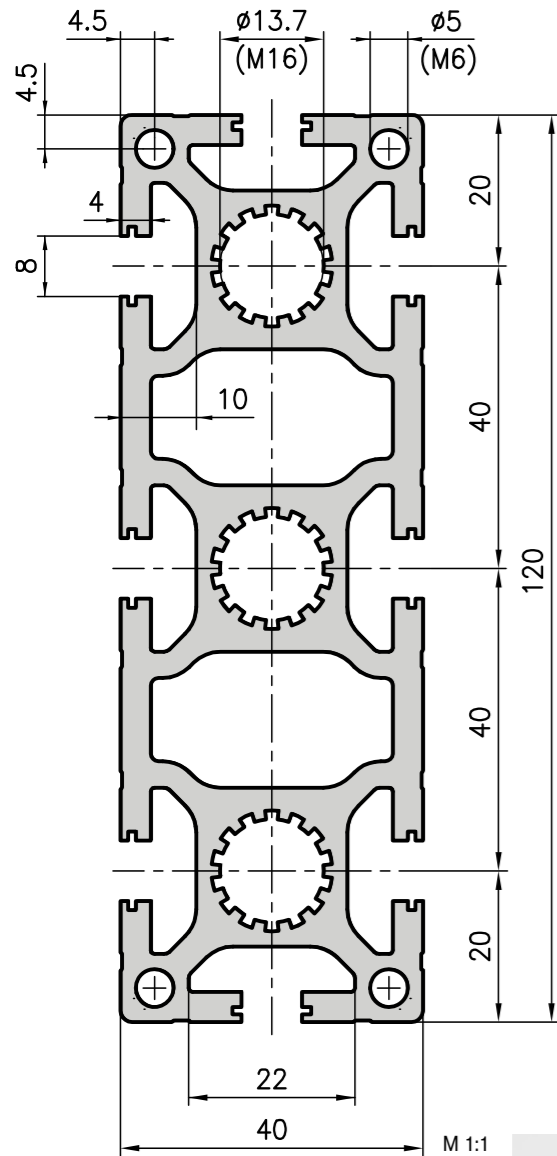

**Application**

The beam extrusion has the same properties as the MA1-3 bearing extrusion (50x150) with slightly lower load-bearing capability.

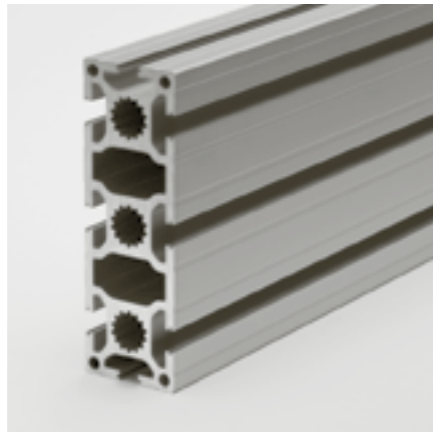

**Technical data**

$I_x$	=	263.20 cm <sup>4</sup>
$I_y$	=	33.94 cm <sup>4</sup>
$W_x$	=	43.09 cm <sup>3</sup>
$W_y$	=	16.72 cm <sup>3</sup>
Cross-section area	=	19.63 cm <sup>2</sup>
Weight	=	5.36 kg/m
Alloy	=	EN AW-6063

**Order data**      **Order number**

40x120 bearing extrusion	
Standard length 5000 mm	C01-9-5M
Standard length 6000 mm	C01-9-6M
40x120 bearing extrusion	
Cut to length	C01-9-02-02/...
Extra machining	<a href="#">Pages 24-46</a>

### 40x160 beam extrusion type C02-9

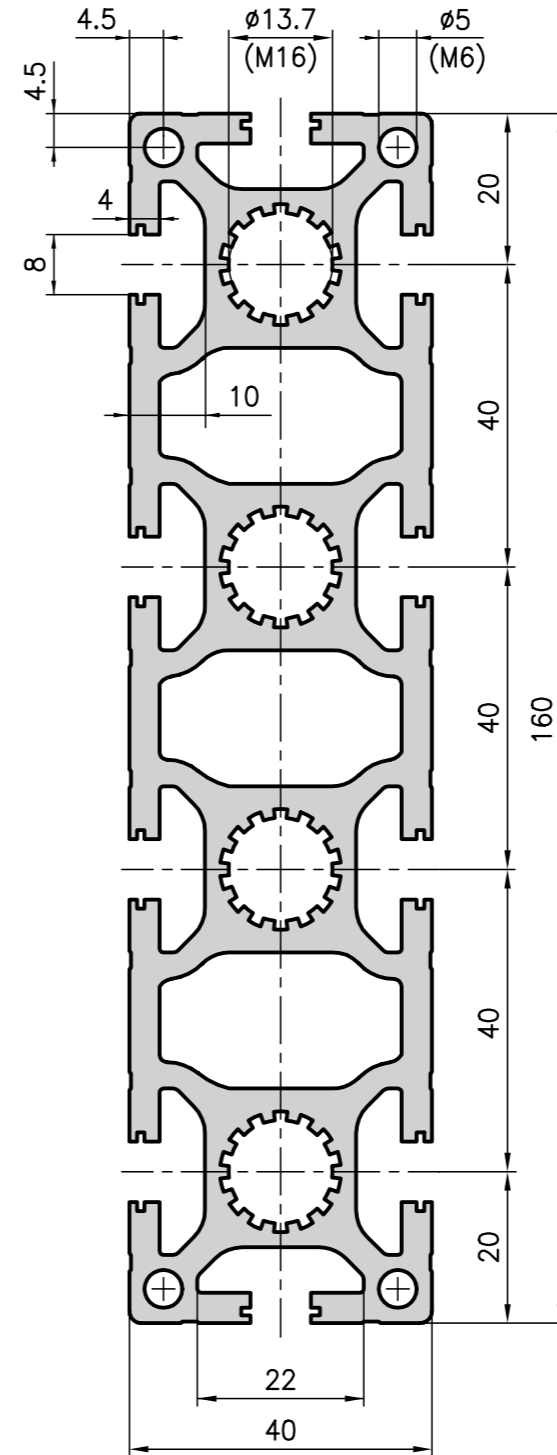

**Application**

This versatile extrusion is particularly useful for structures which are subjected to heavy loads and which span large widths. It can also be used as a multiple supply line for a variety of media.



**Technical data**

$I_x$	=	602.20 cm <sup>4</sup>
$I_y$	=	45.00 cm <sup>4</sup>
$W_x$	=	74.09 cm <sup>3</sup>
$W_y$	=	22.18 cm <sup>3</sup>
Cross-section area	=	25.83 cm <sup>2</sup>
Weight	=	7.0 kg/m
Alloy	=	EN AW-6063

**Order data**      **Order number**

40x160 bearing extrusion	
Standard length 5000 mm	C02-9-5M
Standard length 6000 mm	C02-9-6M
40x160 bearing extrusion	
Cut to length	C02-9-02-02/...
Extra machining	<a href="#">Pages 24-46</a>

### 80x80x40 L-shaped extrusion type C01-6

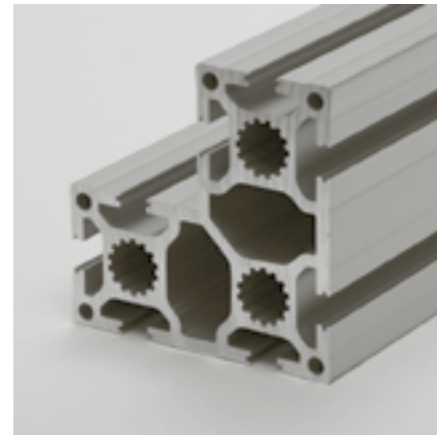
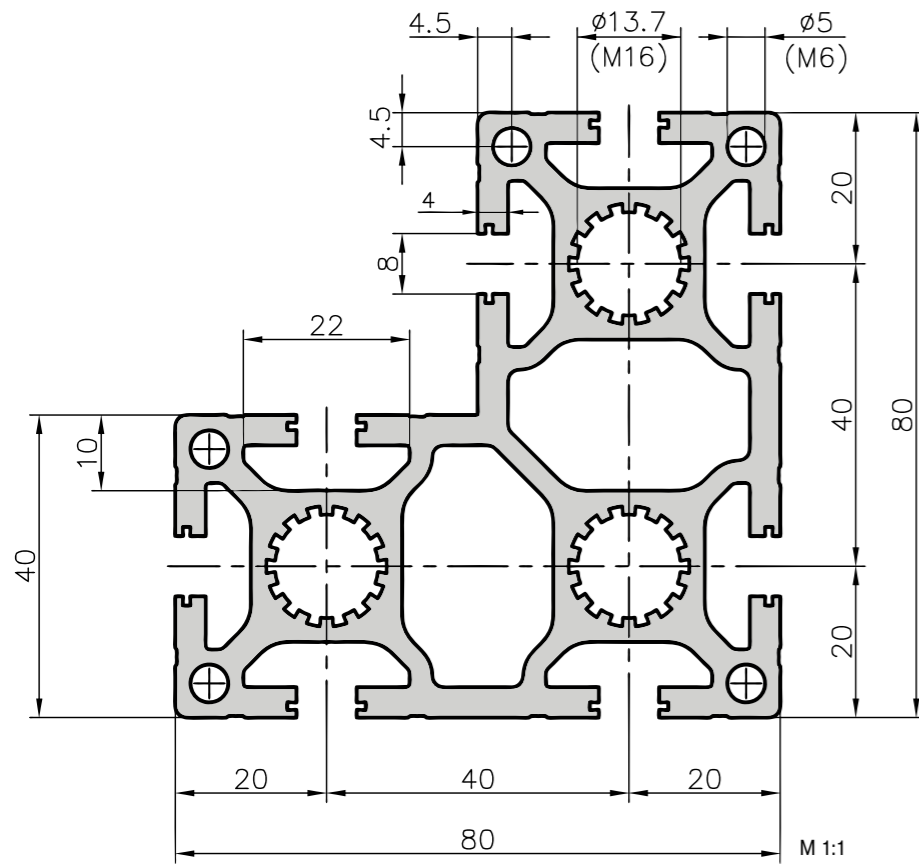

#### Technical data

$I_{x,y}$	=	108.05 cm <sup>4</sup>
$W_{x,y}$	=	23.56 cm <sup>3</sup>
Cross-section area	=	19.59 cm <sup>2</sup>
Weight	=	5.0 kg/m
Alloy	=	EN AW-6063

#### Application

For machine and apparatus frames which have to hold heavy weights and which require strong corner components. They will also be compact and inexpensive.

#### Order data

Order data	Order number
80x80x40 L-shaped extrusion	
Standard length 5000 mm	C01-6-5M
80x80x40 L-shaped extrusion	
Cut to length	C01-6-02-02/...
Extra machining	<a href="#">Pages 24-46</a>

### Corner extrusion 80x80x40 round Type C03-6

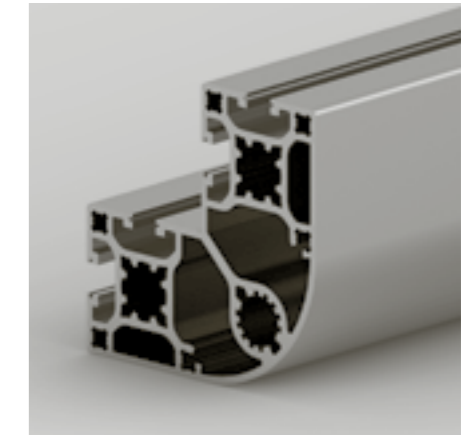
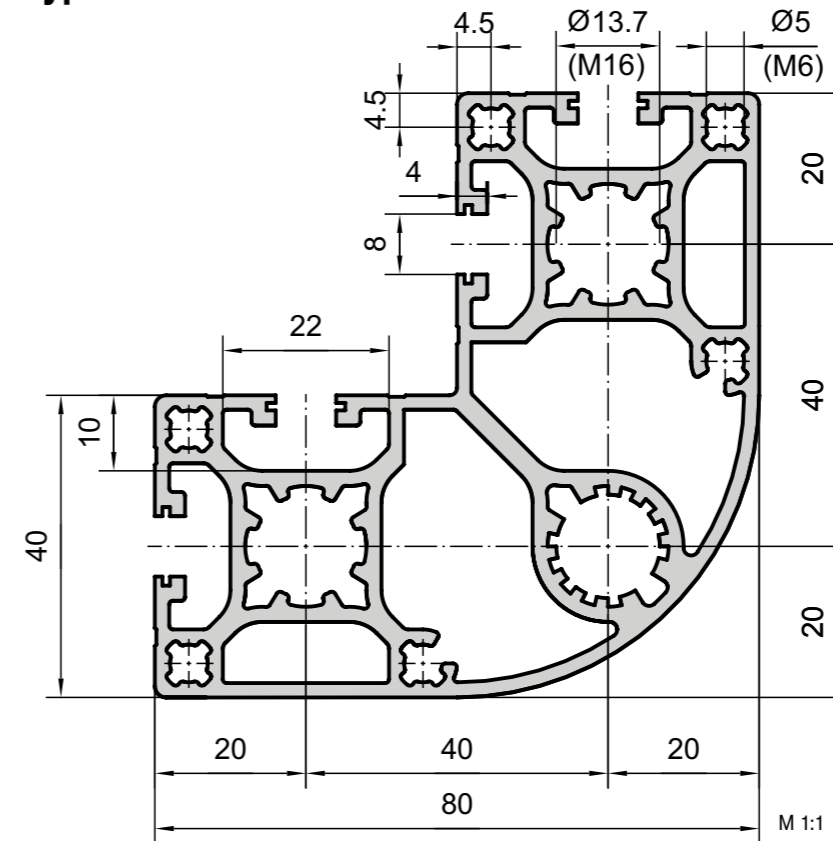

#### Technical data

$I_{x,y}$	=	76.40 cm <sup>4</sup>
$W_{x,y}$	=	19.10 cm <sup>3</sup>
Cross-section area	=	13.33 cm <sup>2</sup>
Weight	=	3.60 kg/m
Alloy	=	EN AW-6060

#### Application

Rounded-off corners result in a soft design. Through the completely closed side, the overall look of a construction becomes more settled. Firmness and flexibility are very high.

#### Order data

Order data	Order number
Corner extrusion 80x80x40 round	
Standard length 5000 mm	C03-6-5M
Corner extrusion 80x80x40 round	
Cut to length	C03-6-02-02/...
Extra machining	<a href="#">Pages 24-46</a>

### 80x80 base extrusion type C01-4

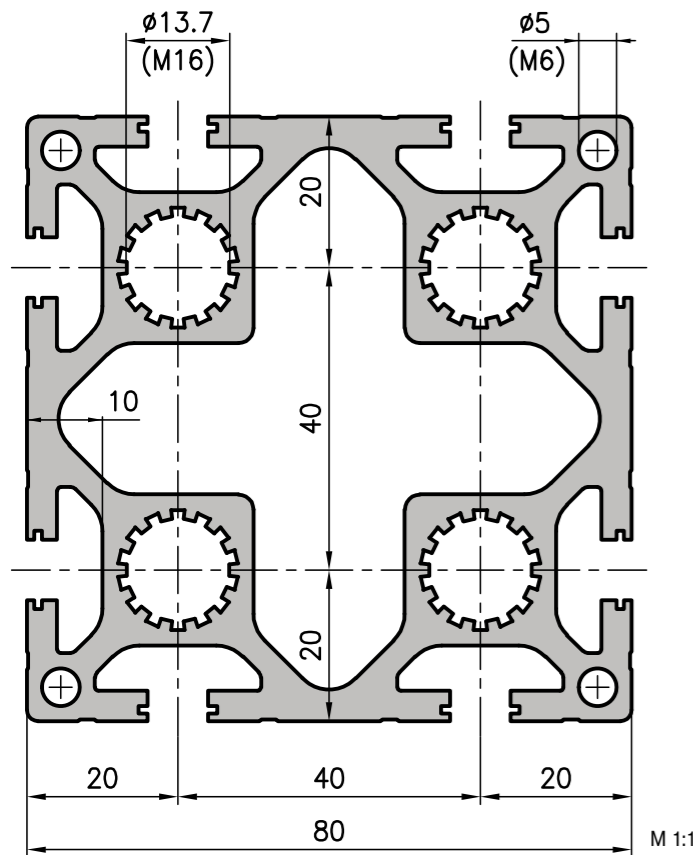

### 80x80 lightweight extrusion type C03-4

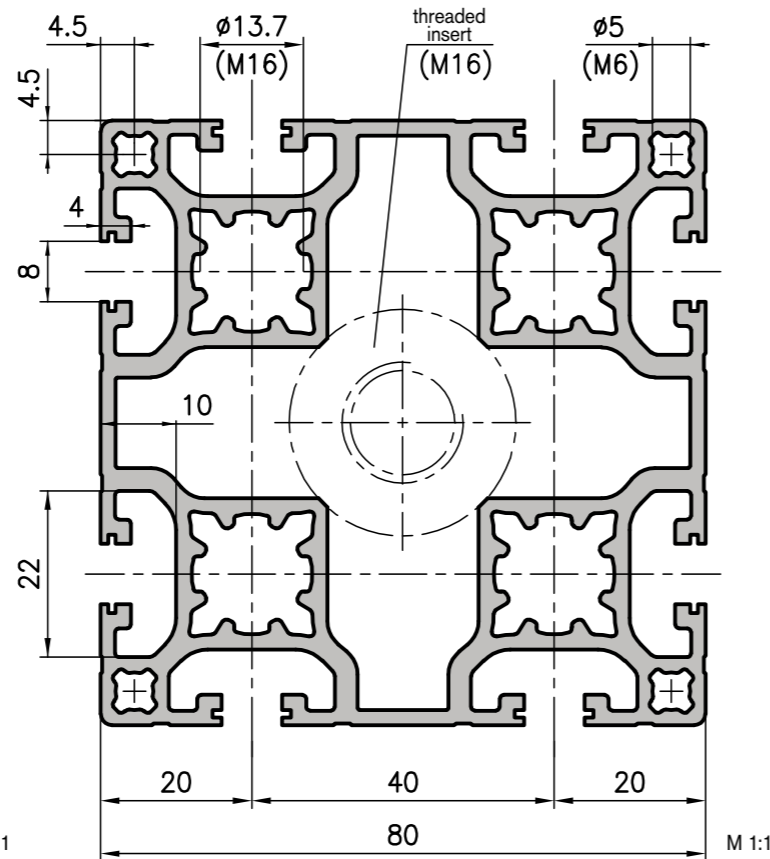

### Corner extrusion 80x80 Type C03-7

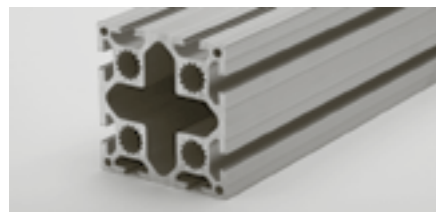
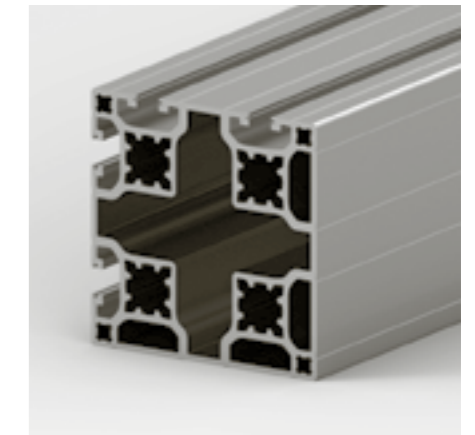
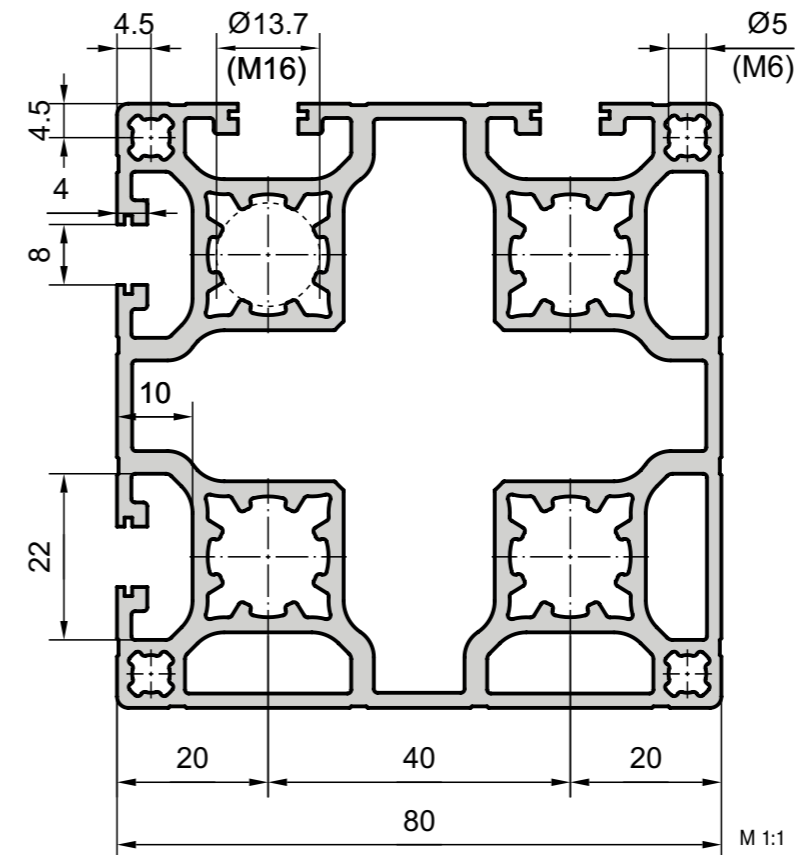

#### Application

This is mainly used as a support, although it can also be used as a cross-beam where higher loads are involved. Especially C01-4 is, of course, also ideal as a reservoir for liquids or gases. The large cavity can also be used effectively for holding load balancing weights. This extrusion is perfect for innovative designers.

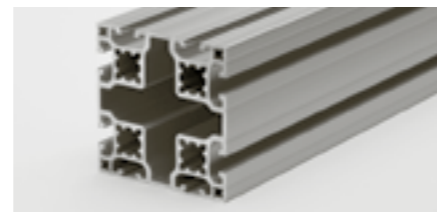

#### Technical data

$I_{x,y}$	=	154.70 cm <sup>4</sup>
$W_{x,y}$	=	38.68 cm <sup>3</sup>
Cross-section area	=	22.10 cm <sup>2</sup>
Weight	=	6.0 kg/m
Alloy	=	EN AW-6063

#### Order data

Order data	Order number
80x80 base extrusion	
Standard length 5000 mm	C01-4-5M
Standard length 6000 mm	C01-4-6M
80x80 base extrusion	
Cut to length	C01-4-02-02/...
Extra machining	<a href="#">Pages 24-46</a>



#### Technical data

$I_{x,y}$	=	115.66 cm <sup>4</sup>
$W_{x,y}$	=	28.92 cm <sup>3</sup>
Cross-section area	=	16.30 cm <sup>2</sup>
Weight	=	4.4 kg/m
Alloy	=	EN AW-6063

#### Order data

Order data	Order number
Lightweight extrusion 80x80	
Standard length 5000 mm	C03-4-5M
Standard length 6000 mm	C03-4-6M
Lightweight extrusion 80x80	
Cut to length	C03-4-02-02/...
Extra machining	<a href="#">Pages 24-46</a>

#### Technical data

$I_{x,y}$	=	117.70 cm <sup>4</sup>
$W_{x,y}$	=	29.43 cm <sup>3</sup>
Cross-section area	=	16.45 cm <sup>2</sup>
Weight	=	4.50 kg/m
Alloy	=	EN AW-6063

#### Order data

Order data	Order number
Corner extrusion 80x80	
Standard length 5000 mm	C03-7-5M
Corner extrusion 80x80	
Cut to length	C03-7-02-02/...
Extra machining	<a href="#">Pages 24-46</a>

#### Application

The corner extrusion 80x80 in lightweight design can also be ideally used as a corner pillar. Its dimension results in a great firmness; the closed fronts are convincing in their design and prevent the depositing of dirt. The profile has very versatile use.

### Beam extrusion 80x120 type MC1-2

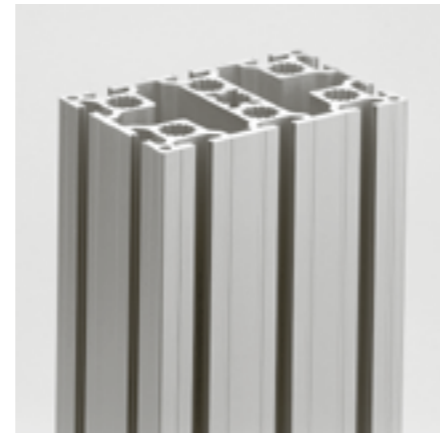
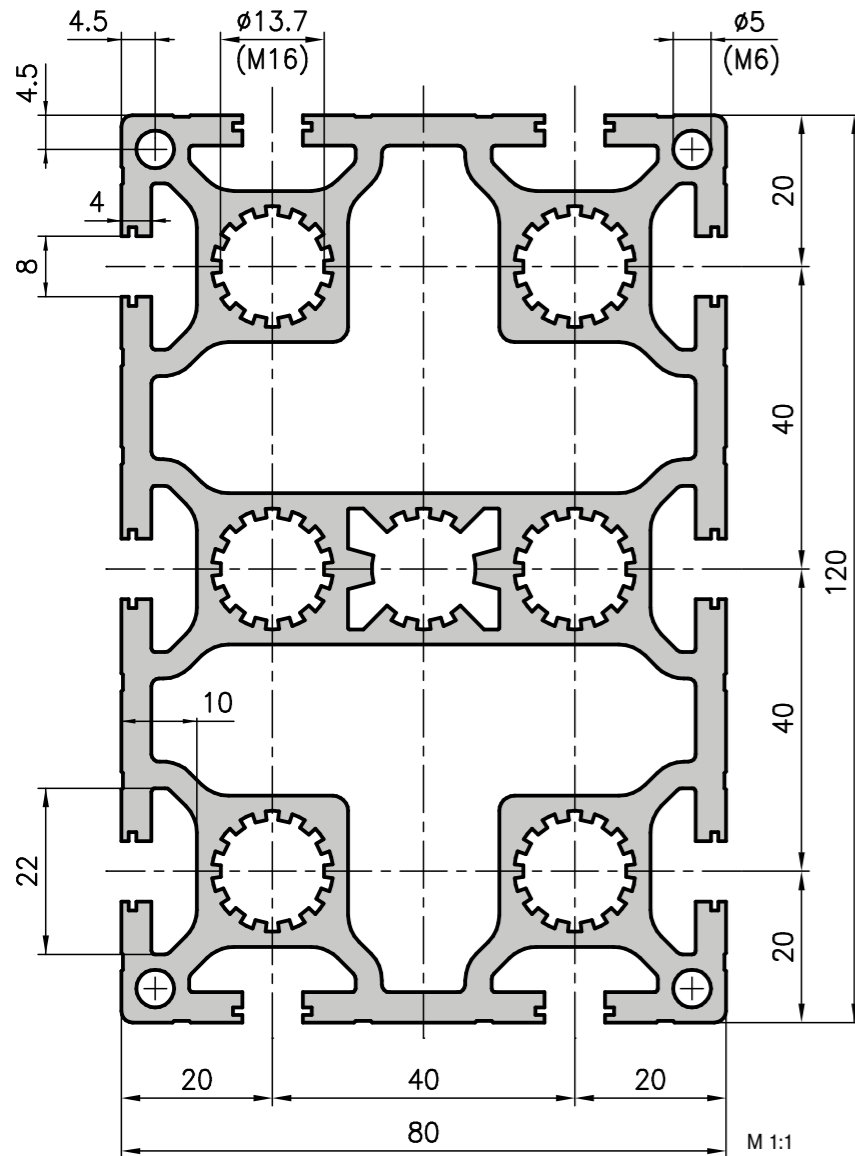

**Application**

A universally useful extrusion with optimum static strength for large gantries and constructions under heavy load.

**Technical data**

$I_x$	=	451.20 cm <sup>4</sup>
$I_y$	=	219.76 cm <sup>4</sup>
$W_x$	=	75.20 cm <sup>3</sup>
$W_y$	=	54.94 cm <sup>3</sup>
Cross-section area	=	31.07 cm <sup>2</sup>
Weight	=	8.40 kg/m
Alloy	=	EN AW-6063

**Order data**      **Order number**

Beam extrusion 80x120	
Standard length 6000 mm	MC1-2-6M
Beam extrusion 80x120	
Cut to length	MC1-2-02-02/...

Extra machining      [Pages 24-46](#)

### 80x160 heavy duty extrusion type MC1-9

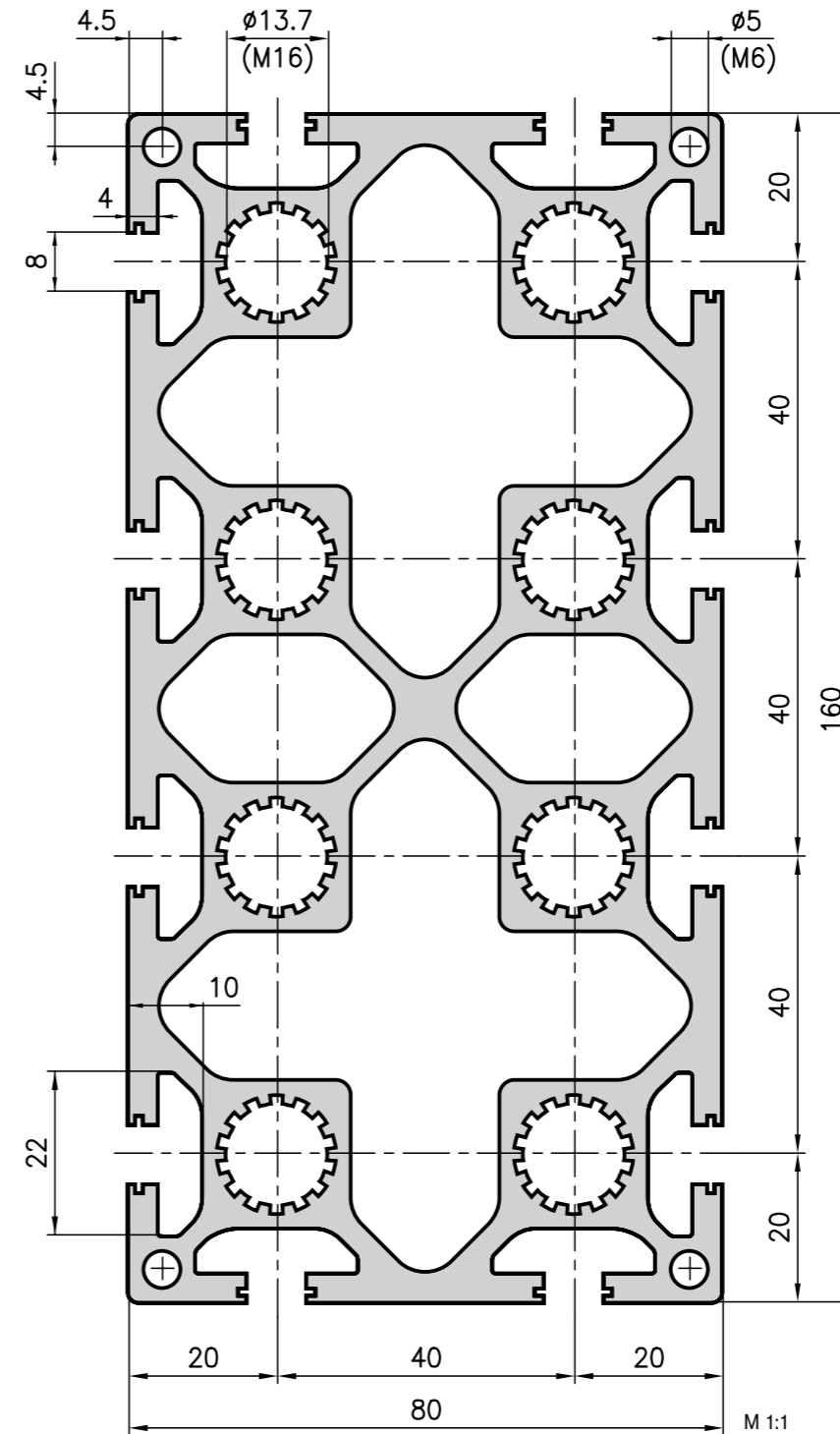

**Application**

This high strength extrusion is used for the construction of gantries and for structures which have to support a heavy load or which have long unsupported sections.

**Technical data**

$I_x$	=	1018.98 cm <sup>4</sup>
$I_y$	=	296.53 cm <sup>4</sup>
$W_x$	=	112.37 cm <sup>3</sup>
$W_y$	=	74.13 cm <sup>3</sup>
Cross-section area	=	40.82 cm <sup>2</sup>
Weight	=	11.0 kg/m
Alloy	=	EN AW-6063

**Order data**      **Order number**

80x160 heavy duty extrusion	
Standard length 5000 mm	MC1-9-5M
Standard length 6000 mm	MC1-9-5M

80x160 heavy duty extrusion	
Cut to length	MC1-9-02-02/...

Extra machining      [Pages 24-46](#)

### Four sided softline extrusion 30x30 type B10-0

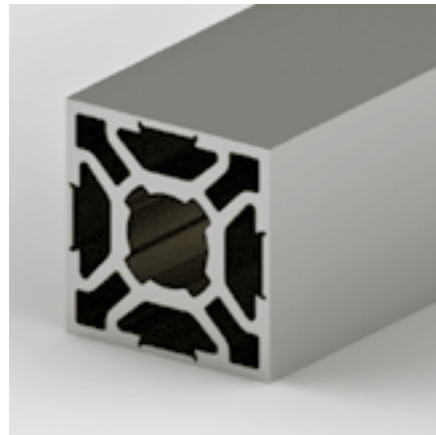
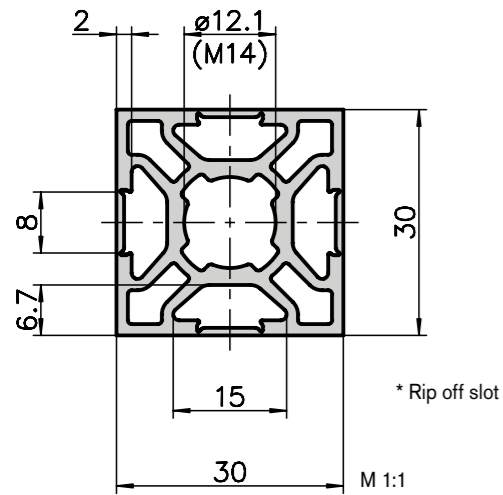

### Super lightweight extrusion 30x30 type B03-1

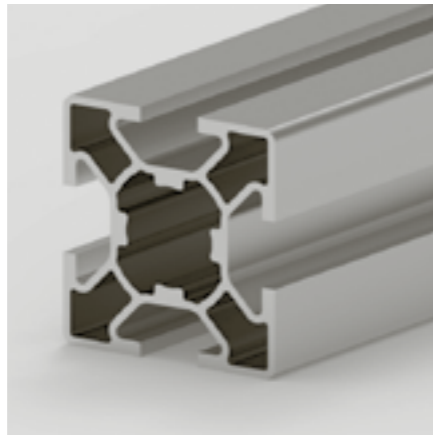
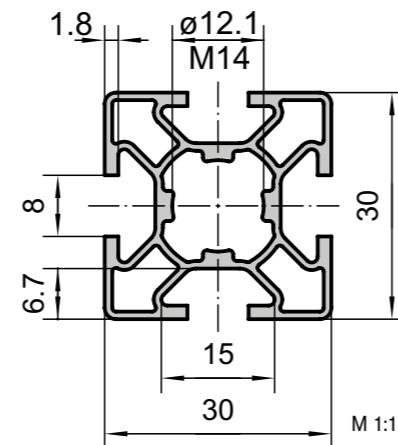

#### Application

These extrusions, which are lightweight and inexpensive, are nonetheless very sturdy and can be universally used for simpler structural designs. Outer casings, safety guards, laboratory rigs and smaller frameworks are all easy to construct using them.

#### Technical data

$I_{x,y}$	=	2.63 cm <sup>4</sup>
$W_{x,y}$	=	1.76 cm <sup>3</sup>
Cross-section area	=	2.62 cm <sup>2</sup>
Weight	=	0.7 kg/m
Alloy	=	EN AW-6060

#### Order data Order number

Super lightweight extrusion 30x30	
Standard length 5000 mm	B03-1-5M
Super lightweight extrusion 30x30	
Cut to length	B03-1-02-02/...
Extra machining	<a href="#">Pages 24-46</a>

### Lightweight extrusion 30x30 type B02-1

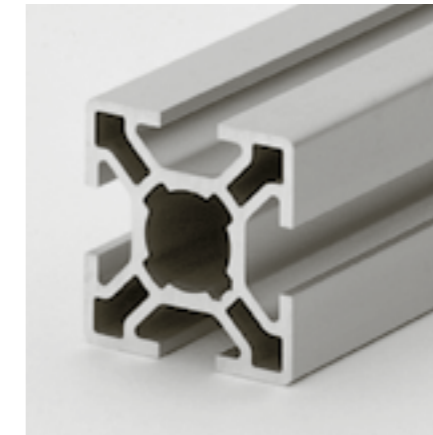
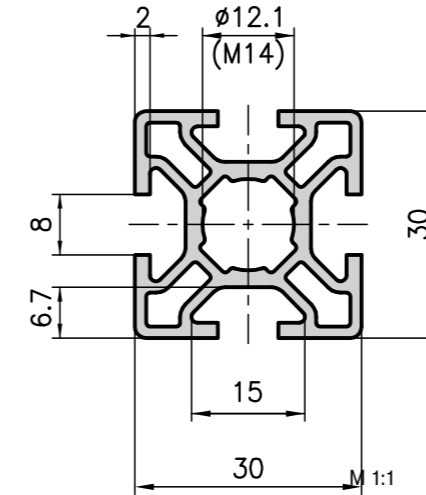

#### Application

With slots on all sides, this universally used lightweight extrusion is optimally constructed with regard to weight and strength. For lightweight enclosures and other small constructions, this is an inexpensive and sturdy extrusion.

#### Technical data

$I_{x,y}$	=	2.95 cm <sup>4</sup>
$W_{x,y}$	=	1.97 cm <sup>3</sup>
Cross-section area	=	3.27 cm <sup>2</sup>
Weight	=	0.9 kg/m
Alloy	=	EN AW-6063

#### Order data Order number

Lightweight extrusion 30x30	
Standard length 5000 mm	B02-1-5M
Lightweight extrusion 30x30	
Cut to length	B02-1-02-02/...
Extra machining	<a href="#">Pages 24-46</a>

### Heavy duty extrusion 30x30 type MB1-1

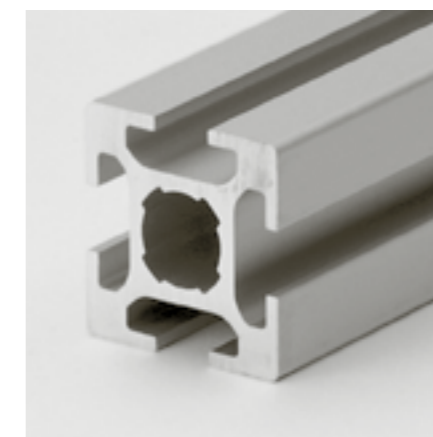
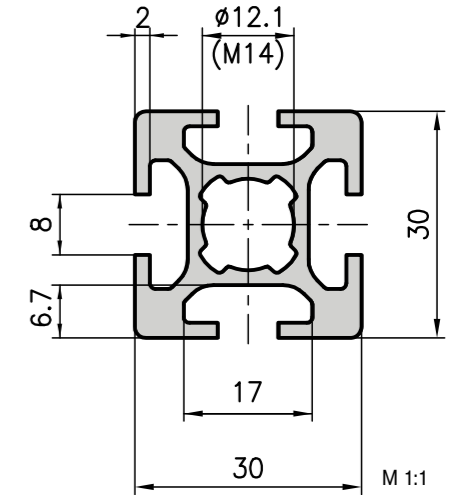

#### Application

The counterpart to the lightweight extrusion. It gives the designer plenty of scope for designing: trolleys, machine frames, load-bearing structures, etc.

#### Technical data

$I_{x,y}$	=	3.82 cm <sup>4</sup>
$W_{x,y}$	=	2.54 cm <sup>3</sup>
Cross-section area	=	4.10 cm <sup>2</sup>
Weight	=	1.1 kg/m
Alloy	=	EN AW-6063

#### Order data Order number

Heavy duty extrusion 30x30	
Standard length 5000 mm	MB1-1-5M
Heavy duty extrusion 30x30	
Cut to length	MB1-1-02-02/...
Extra machining	<a href="#">Pages 24-46</a>

### 30x30 face extrusion type B03-2

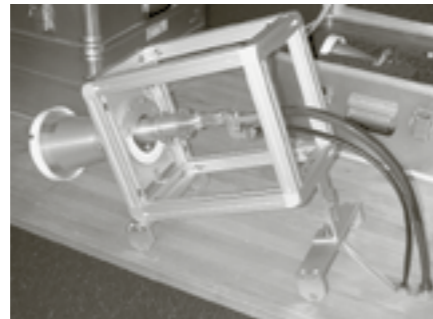
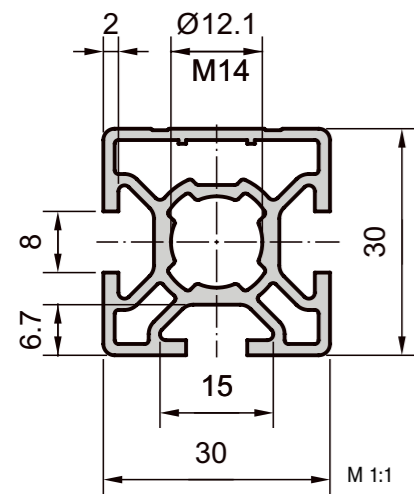

### 30x30 face extrusion with panel slots type B02-2

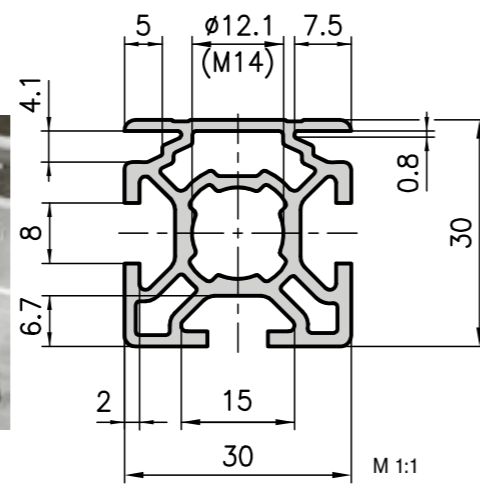

### 30x30 corner extrusion type B02-3

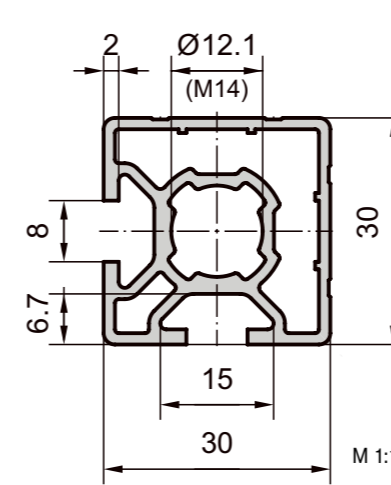

### 30x30 corner extrusion with panel slots type B01-3

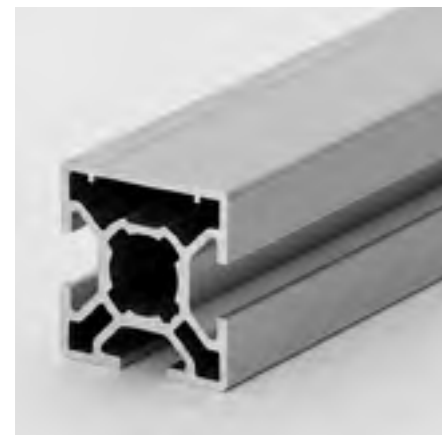
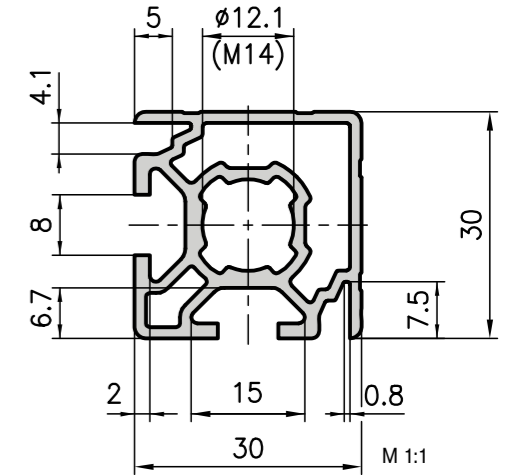

#### Application

For lightweight machine frames, protective guards, safety fencing, etc. Metal paneling sheets, as well as composite panels, acrylic glass panels and all-plastic panels up to 4 mm in thickness can be fixed in place into the panel slots on the face extrusions.

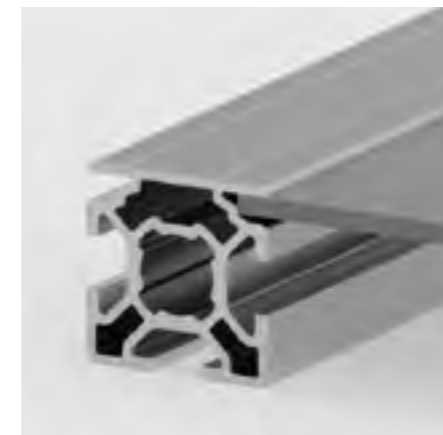

#### Application

Workstation design, enclosures, apparatus trolleys and more lightweight structures. This corner profile looks extremely compact because it is closed on two sides and is the natural choice in any application where only two slots are required for joining components together. Metal and/or composite panels are easy to fit as enclosure elements thanks to the additional panel slots.

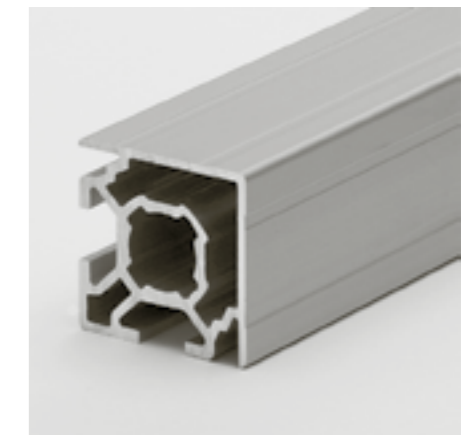

#### Technical data

$I_x$	=	2.85 cm <sup>4</sup>
$I_y$	=	2.83 cm <sup>4</sup>
$W_x$	=	1.90 cm <sup>3</sup>
$W_y$	=	1.83 cm <sup>3</sup>
Cross-section area	=	3.10 cm <sup>2</sup>
Weight	=	0.8 kg/m
Alloy	=	EN AW-6063

#### Order data

Order data	Order number
30x30 face extrusion	
Standard length 5000 mm	B03-2-5M
30x30 face extrusion	
Cut to length	B03-2-02-02/...
Extra machining	<a href="#">Pages 24-46</a>



#### Technical data

$I_x$	=	2.93 cm <sup>4</sup>
$I_y$	=	2.76 cm <sup>4</sup>
$W_x$	=	1.93 cm <sup>3</sup>
$W_y$	=	1.84 cm <sup>3</sup>
Cross-section area	=	3.18 cm <sup>2</sup>
Weight	=	0.9 kg/m
Alloy	=	EN AW-6063

#### Order data

Order data	Order number
30x30 face enclosure extrusion	
Standard length 5000 mm	B02-2-5M
30x30 face enclosure extrusion	
Cut to length	B02-2-02-02/...
Extra machining	<a href="#">Pages 24-46</a>

#### Technical data

$I_{x,y}$	=	2.70 cm <sup>4</sup>
$W_{x,y}$	=	1.75 cm <sup>3</sup>
Cross-section area	=	2.95 cm <sup>2</sup>
Weight	=	0.8 kg/m
Alloy	=	EN AW-6063

#### Order data

Order data	Order number
30x30 corner extrusion	
Standard length 5000 mm	B02-3-5M
30x30 corner extrusion	
Cut to length	B02-3-02-02/...
Extra machining	<a href="#">Pages 24-46</a>

#### Technical data

$I_{x,y}$	=	2.70 cm <sup>4</sup>
$W_{x,y}$	=	1.75 cm <sup>3</sup>
Cross-section area	=	2.98 cm <sup>2</sup>
Weight	=	0.8 kg/m
Alloy	=	EN AW-6063

#### Order data

Order data	Order number
30x30 corner enclosure extrusion	
Standard length 5000 mm	B01-3-5M
30x30 corner enclosure extrusion	
Cut to length	B01-3-02-02/...
Extra machining	<a href="#">Pages 24-46</a>

### 30x30 double face extrusion type B02-4

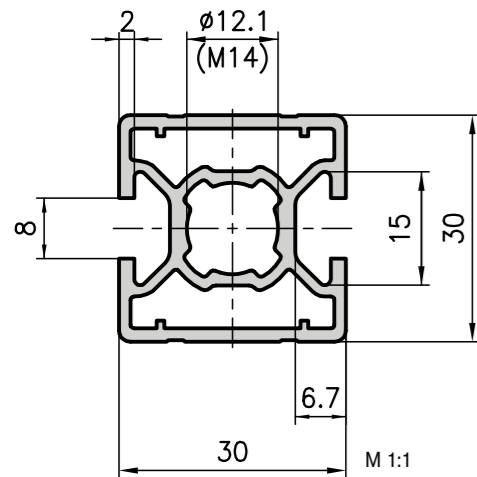

#### Application

For all types of enclosure, as well as for structures with extrusion faces which are mainly closed and for applications with an attractive design.



#### Technical data

$I_x$	=	2.73 cm <sup>4</sup>
$I_y$	=	2.74 cm <sup>4</sup>
$W_x$	=	1.82 cm <sup>3</sup>
$W_y$	=	1.83 cm <sup>3</sup>
Cross-section area	=	2.91 cm <sup>2</sup>
Weight	=	0.8 kg/m
Alloy	=	EN AW-6063

#### Order data Order number

30x30 double face extrusion	
Standard length 5000 mm	B02-4-5M
30x30 double face extrusion	
Cut to length	B02-4-02-02/...
Extra machining	<a href="#">Pages 24-46</a>

### 30x30 softline extrusion type B01-8

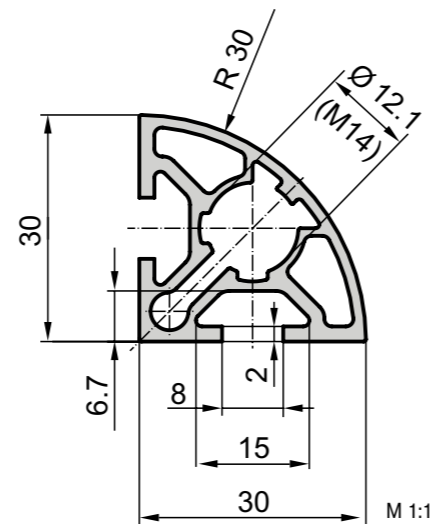

#### Application

This extrusion is used to build furniture, display cases and other objects without obtrusive sharp edges.



#### Technical data

$I_{x, y}$	=	2.16 cm <sup>4</sup>
$W_{x, y}$	=	1.44 cm <sup>3</sup>
Cross-section area	=	2.56 cm <sup>2</sup>
Weight	=	0.7 kg/m
Alloy	=	EN AW-6060

#### Order data Order number

30x30 softline extrusion	
Standard length 5000 mm	B01-8-5M
30x30 softline extrusion	
Cut to length	B01-8-02-02/...
Extra machining	<a href="#">Pages 24-46</a>

### 30° angle extrusion type B04-3

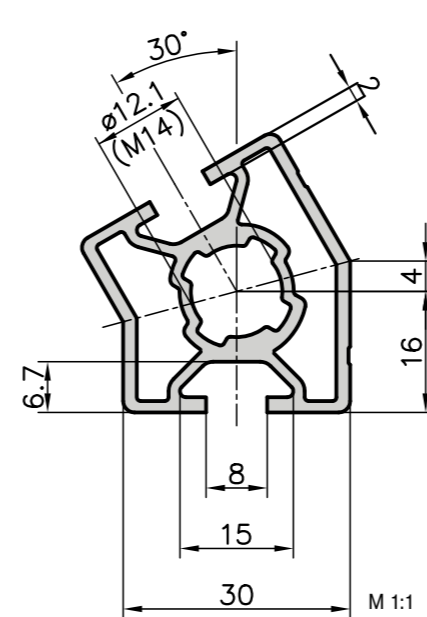

#### Application

For stands, tables, safety guards or display cabinets with sloping surfaces or for any angled construction. This group of extrusions ensures elegant shapes.



#### Technical data

$I_x$	=	3.23 cm <sup>4</sup>
$I_y$	=	2.89 cm <sup>4</sup>
$W_x$	=	1.54 cm <sup>3</sup>
$W_y$	=	1.48 cm <sup>3</sup>
Cross-section area	=	3.13 cm <sup>2</sup>
Weight	=	0.9 kg/m
Alloy	=	EN AW-6060

#### Order data Order number

30° angle extrusion	
Standard length 5000 mm	B04-3-5M
30° angle extrusion	
Cut to length	B04-3-02-02/...
Extra machining	<a href="#">Pages 24-46</a>

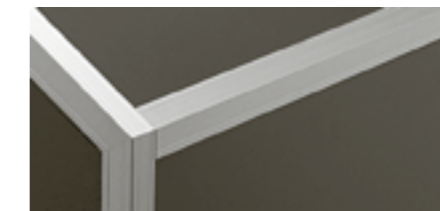

### 45° angle extrusion type B04-4

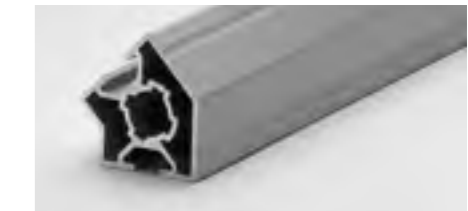
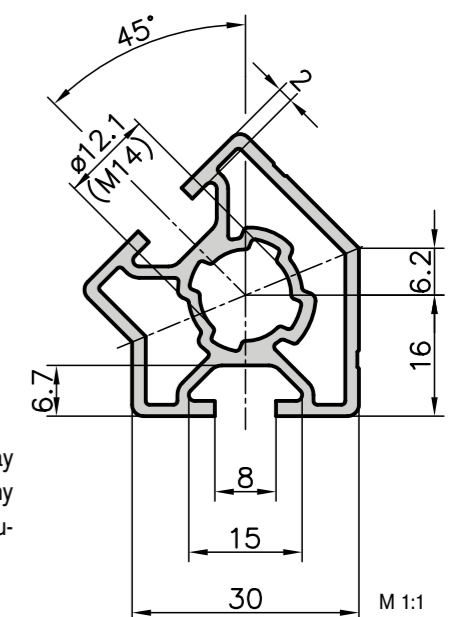

#### Technical data

$I_x$	=	3.14 cm <sup>4</sup>
$I_y$	=	2.91 cm <sup>4</sup>
$W_x$	=	1.44 cm <sup>3</sup>
$W_y$	=	1.45 cm <sup>3</sup>
Cross-section area	=	3.13 cm <sup>2</sup>
Weight	=	0.9 kg/m
Alloy	=	EN AW-6060

#### Order data Order number

45° angle extrusion	
Standard length 5000 mm	B04-4-5M
45° angle extrusion	
Cut to length	B04-4-02-02/...
Extra machining	<a href="#">Pages 24-46</a>

### 60° angle extrusion type B04-6

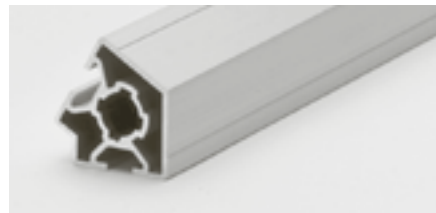
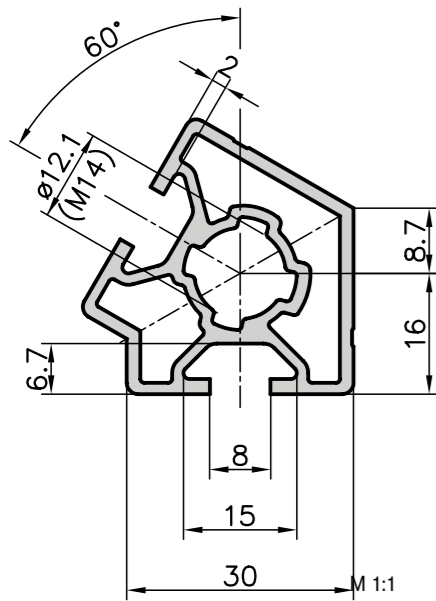

#### Technical data

Ix	=	3.07 cm <sup>4</sup>
Iy	=	2.94 cm <sup>4</sup>
Wx	=	1.45 cm <sup>3</sup>
Wy	=	1.51 cm <sup>3</sup>
Cross-section area	=	3.04 cm <sup>2</sup>
Weight	=	0.9 kg/m
Alloy	=	EN AW-6060

#### Order data

Order data	Order number
60° angle extrusion Standard length 5000 mm	B04-6-5M
60° angle extrusion Cut to length	B04-6-02-02/...
Extra machining	<a href="#">Pages 24-46</a>

### Base extrusion 30x50 type B01-9

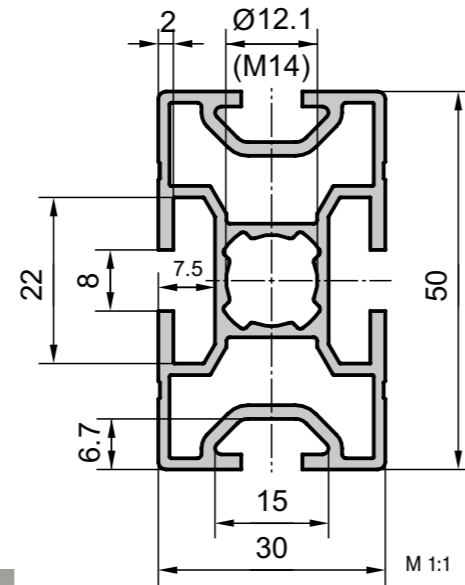

#### Application

Used for all types of structures, base frames, trolleys, conveyor belts, etc. Universally used, easy to use in conjunction with extrusions with bases of 30, 40, 45 or 50. This extrusion is sturdy and strong, despite using little aluminium.

#### Technical data

Ix	=	10.94 cm <sup>4</sup>
Iy	=	4.33 cm <sup>4</sup>
Wx	=	4.38 cm <sup>3</sup>
Wy	=	2.90 cm <sup>3</sup>
Cross-section area	=	4.34 cm <sup>2</sup>
Weight	=	1.2 kg/m
Alloy	=	EN AW-6063

#### Order data

Order data	Order number
Base extrusion 30x50 Standard length 5000 mm	B01-9-5M
Base extrusion 30x50 Cut to length	B01-9-02-02/...
Extra machining	<a href="#">Pages 24-46</a>

### 30x50 face extrusion with panel slots type MB1-9

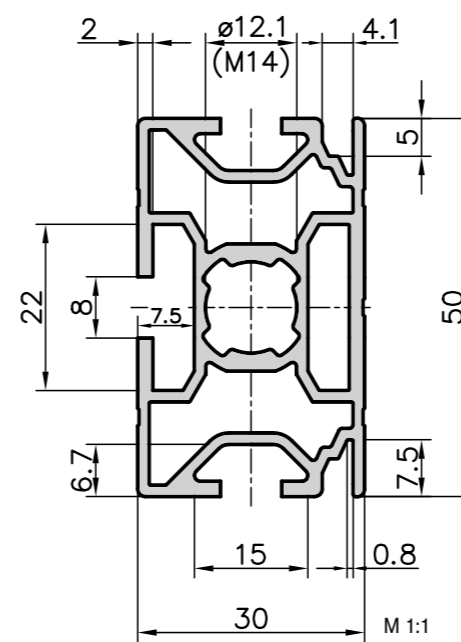

#### Application

The narrow slots hold panels measuring up to 4 mm in thickness securely and firmly in place. Therefore, this extrusion is ideal in any application where covers and cladding of various types are being fitted.

#### Technical data

Ix	=	11.25 cm <sup>4</sup>
Iy	=	4.84 cm <sup>4</sup>
Wx	=	4.50 cm <sup>3</sup>
Wy	=	3.23 cm <sup>3</sup>
Cross-section area	=	5.00 cm <sup>2</sup>
Weight	=	1.3 kg/m
Alloy	=	EN AW-6063

#### Order data

Order data	Order number
30x50 face extrusion with panel slots Standard length 5000 mm	MB1-9-5M
30x50 face extrusion with panel slots Cut to length	MB1-9-02-02/...

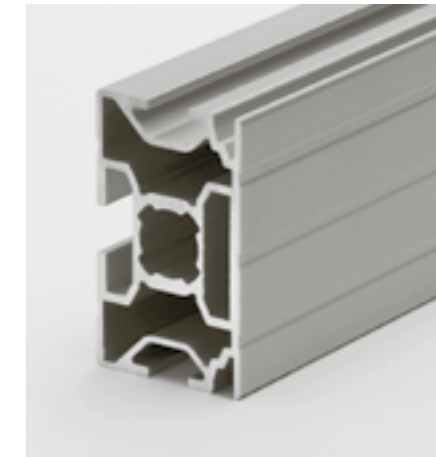

#### Application

Ideal for any application which requires an attractive design and structural stability. This is another versatile extrusion which can be used for tackling a wide range of different problems.

These extrusions need a special barrel if the connector is fitted on the short side (see image). The connectors with the long barrels have the following item numbers:

#### Order data

Order data	Order number
Round-headed connector	B215-90
Horizontal-headed connector	B215-10
Vertical-headed connector	B215-20

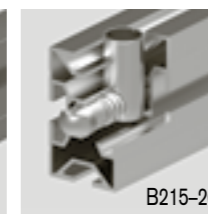
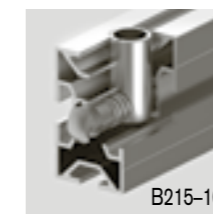

Extra machining

[Pages 24-46](#)

### Face extrusion 30x50 type MB2-9

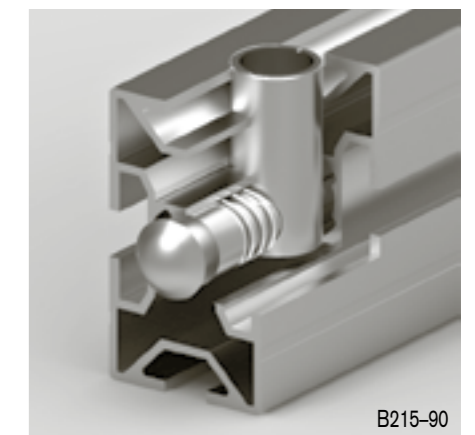
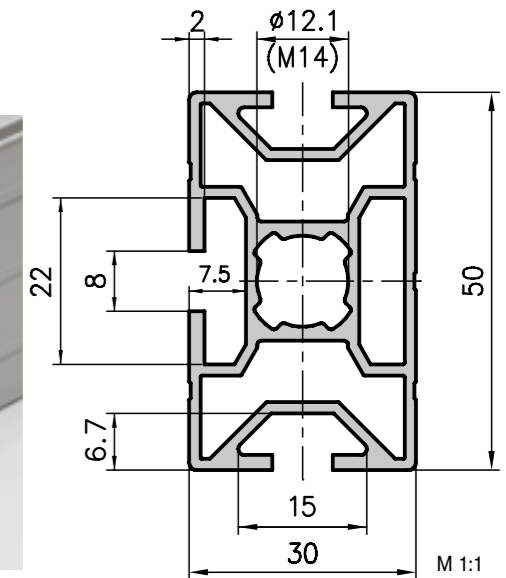

#### Technical data

Ix	=	11.30 cm <sup>4</sup>
Iy	=	4.55 cm <sup>4</sup>
Wx	=	4.52 cm <sup>3</sup>
Wy	=	3.03 cm <sup>3</sup>
Cross-section area	=	4.52 cm <sup>2</sup>
Weight	=	1.3 kg/m
Alloy	=	EN AW-6063

#### Order data

Order data	Order number
Face extrusion 30x50 Standard length 5000 mm	MB2-9-5M
Face extrusion 30x50 Cut to length	MB2-9-02-02/...





### 30x100 base extrusion type MB1-2

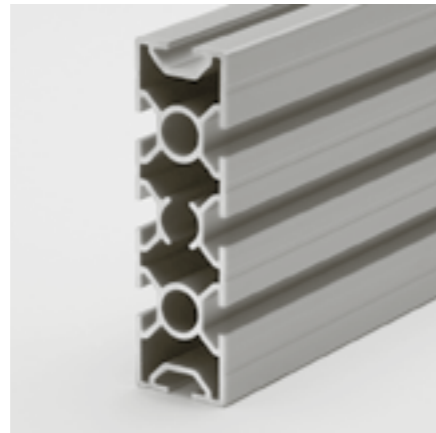
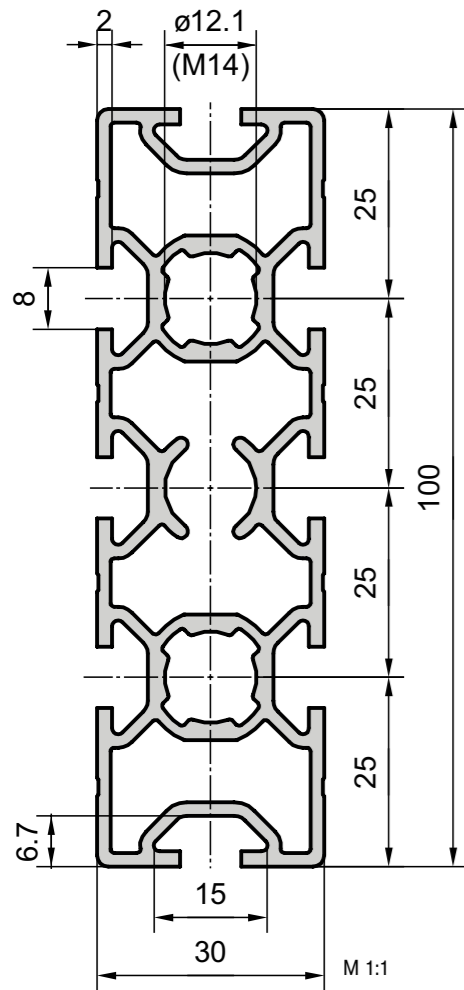

#### Application

For cross-beams on base frames, conveyor belts, trolleys or for large areas of panelling. This versatile extrusion can also be used in combination with extrusions with a base of 40 or 50 mm. A lightweight, sturdy extrusion which can be connected in many different configuration.

#### Technical data

$I_x$	=	80.77 cm <sup>4</sup>
$I_y$	=	8.95 cm <sup>4</sup>
$W_x$	=	16.15 cm <sup>3</sup>
$W_y$	=	5.97 cm <sup>3</sup>
Cross-section area	=	8.59 cm <sup>2</sup>
Weight	=	2.3 kg/m
Alloy	=	EN AW-6060

#### Order data Order number

30x100 base extrusion	
Standard length 5000 mm	MB1-2-5M
30x100 base extrusion	
Cut to length	MB1-2-02-02/...

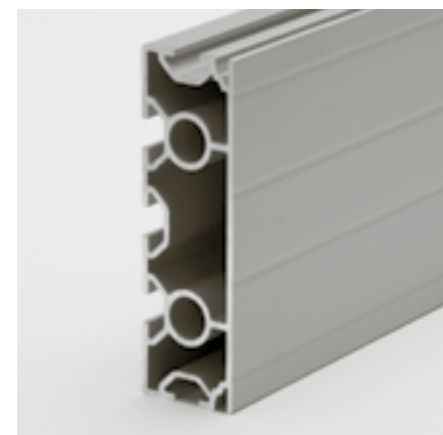

Extra machining

[Pages 24-46](#)

### 30x100 face extrusion with panel slots type B01-2

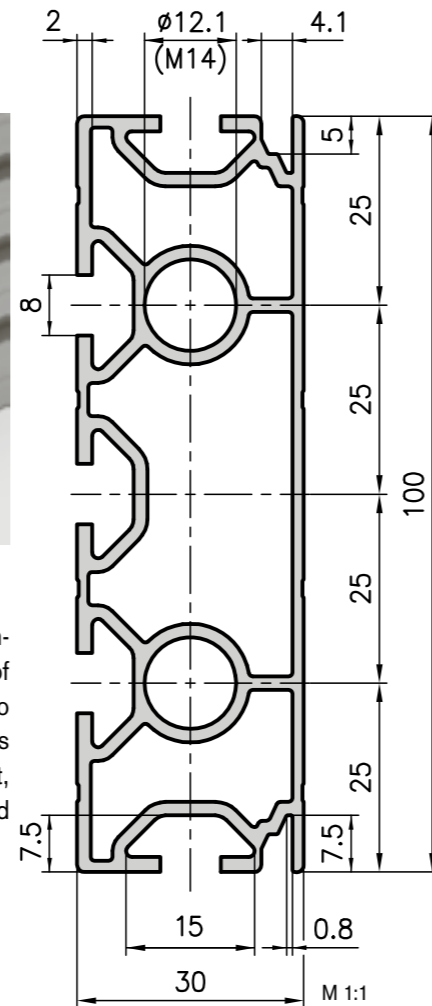

#### Technical data

$I_x$	=	77.86 cm <sup>4</sup>
$I_y$	=	8.79 cm <sup>4</sup>
$W_x$	=	15.57 cm <sup>3</sup>
$W_y$	=	5.72 cm <sup>3</sup>
Cross-section area	=	7.72 cm <sup>2</sup>
Weight	=	2.1 kg/m
Alloy	=	EN AW-6060

#### Order data Order number

30x100 face enclosure extrusion	
Standard length 5000 mm	B01-2-5M
30x100 face enclosure extrusion	
Cut to length	B01-2-02-02/...

### 30x300 face extrusion type B03-3

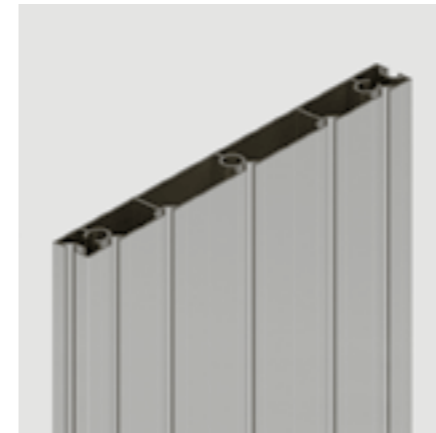

#### Application

Positioned on its edge, this extrusion can be used as a cross-beam to support heavy loads. However, it can also be used as a bed plate or as a superior panel.

#### Technical data

$I_x$	=	1755.64 cm <sup>4</sup>
$I_y$	=	26.06 cm <sup>4</sup>
$W_x$	=	117.04 cm <sup>3</sup>
$W_y$	=	17.30 cm <sup>3</sup>
Cross-section area	=	18.74 cm <sup>2</sup>
Weight	=	5.10 kg/m
Alloy	=	EN AW-6063

#### Order data Order number

30x300 face extrusion	
Standard length 5000 mm	B03-3-5M
30x300 face extrusion	
Cut to length	B03-3-02-02/...

Extra machining

[Pages 24-46](#)

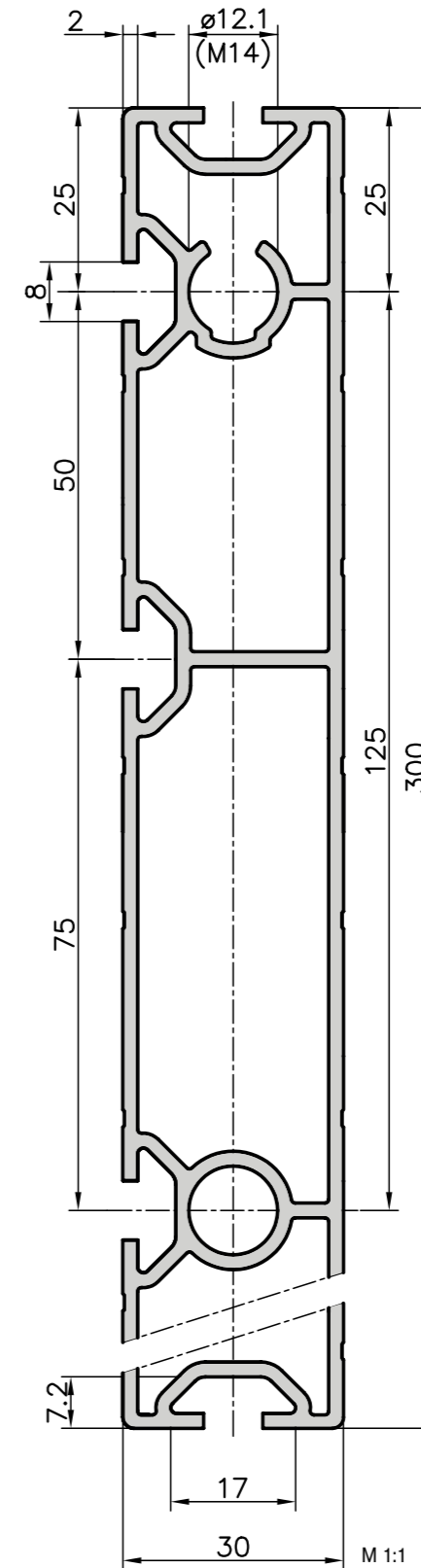

### Tube extrusion ø30 type R03-98

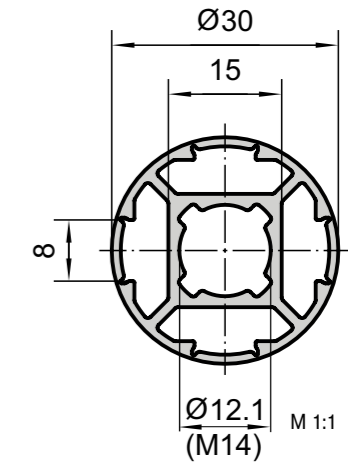

#### Application

This round tube is very suitable for simple handrails and can be combined well with the rectangular tubes using the corresponding fixing elements.

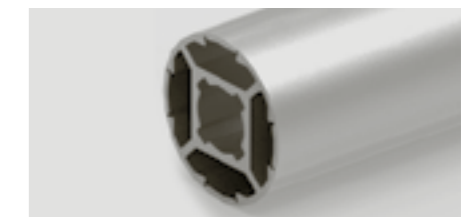

#### Technical data

$I_{x,y}$	=	13.13 cm <sup>4</sup>
$W_{x,y}$	=	8.75 cm <sup>3</sup>
Cross-section area	=	2.35 cm <sup>2</sup>
Weight	=	0.64 kg/m
Alloy	=	EN AW-6063

#### Order data Order number

Tube extrusion ø30	
Standard length 6000 mm	R03-98-6M
Tube extrusion ø30	
Cut to length	R03-98-02-02/...

Extra machining

[Pages 24-46](#)

### 20x20 base extrusion type D01-5

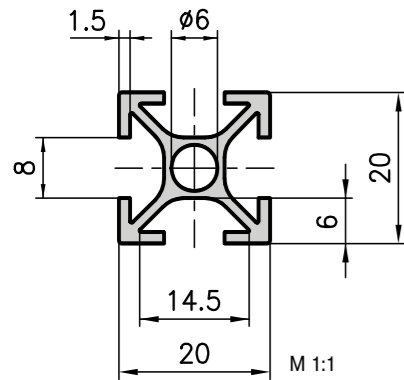

### 20x20 corner extrusion type D01-3

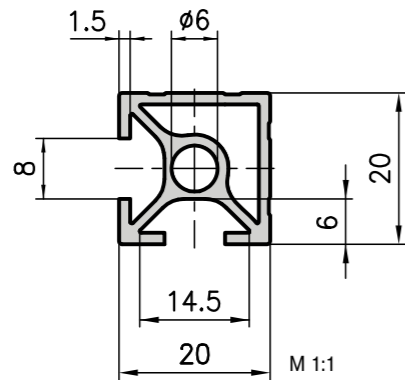

### 20x20 face extrusion type D01-8

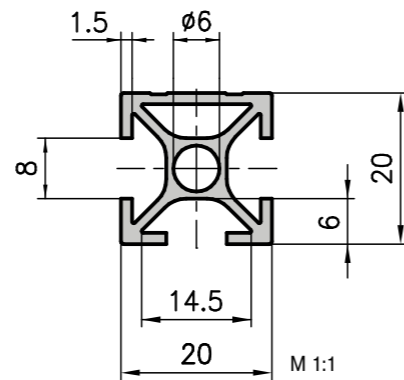

### 20x20 Softline extrusion type D03-8

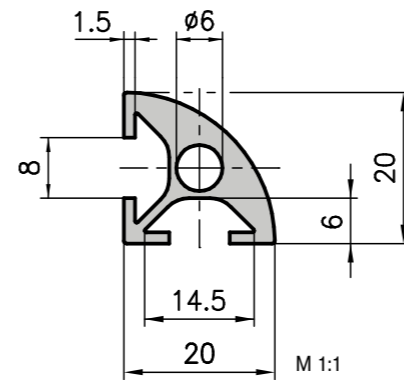

### 20x40 base extrusion type D01-7

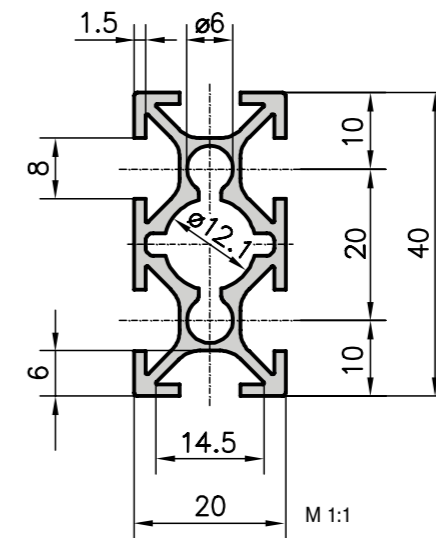

### 20x40 face extrusion type D02-8

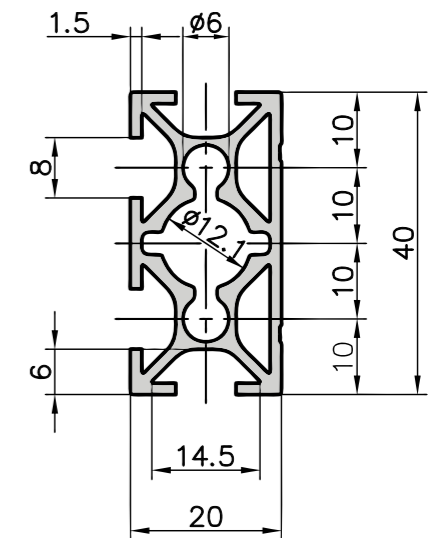

**Application**  
Due to their relatively low weight and strength this 20x20/40 range of extrusions can only be used for small loads, such as limit switches fixtures, smart work frames, small display cases, etc.

Helicoil inserts (DIN 8140) can be used for all extrusions with a core hole of Ø6. See machining code H3/H4.

The 20x20 and 20x40 extrusions are also suitable as a support or reinforcement extrusion behind panels, which is in combination with the base 30 extrusion with panel slots (see sketch).

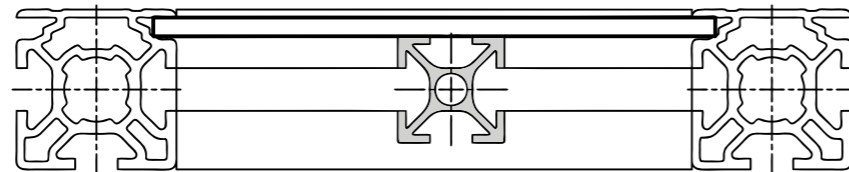

**Application**  
For small picture frames as well as for decorative application.

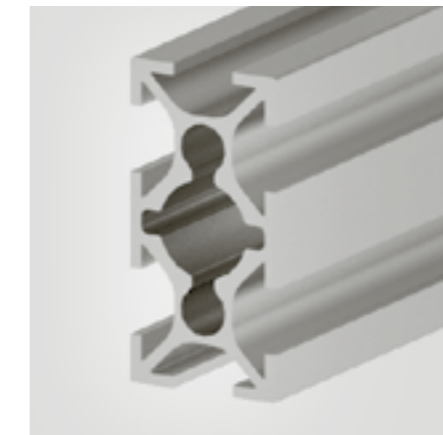

**Application**  
A multi purpose extrusion, which is easily compatible with the base 40. The center hole is Ø12.1 so that the bigger connectors can also be used, making application possibilities even more versatile.

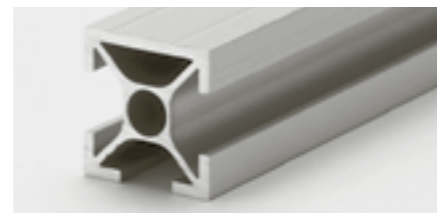
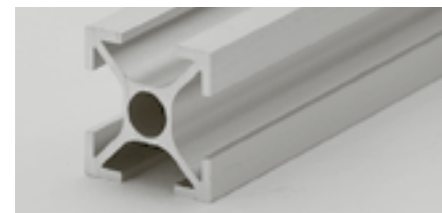

Technical data	
$I_{x,y}$	= 0.60 cm <sup>4</sup>
$W_{x,y}$	= 0.60 cm <sup>3</sup>
Cross-section area	= 1.40 cm <sup>2</sup>
Weight	= 0.38 kg/m
Alloy	EN AW-6060

Technical data	
$I_{x,y}$	= 0.65 cm <sup>4</sup>
$W_{x,y}$	= 0.65 cm <sup>3</sup>
Cross-section area	= 1.54 cm <sup>2</sup>
Weight	= 0.42 kg/m
Alloy	EN AW-6063

Technical data	
$I_x$	= 0.68 cm <sup>4</sup>
$I_y$	= 0.59 cm <sup>4</sup>
$W_x$	= 0.68 cm <sup>3</sup>
$W_y$	= 0.59 cm <sup>3</sup>
Cross-section area	= 1.46 cm <sup>2</sup>
Weight	= 0.39 kg/m
Alloy	EN AW-6063

Technical data	
$I_{x,y}$	= 0.47 cm <sup>4</sup>
$W_{x,y}$	= 0.47 cm <sup>3</sup>
Cross-section area	= 1.29 cm <sup>2</sup>
Weight	= 0.35 kg/m
Alloy	EN AW-6060

Technical data	
$I_x$	= 3.91 cm <sup>4</sup>
$I_y$	= 1.10 cm <sup>4</sup>
$W_x$	= 1.95 cm <sup>3</sup>
$W_y$	= 1.10 cm <sup>3</sup>
Cross-section area	= 2.69 cm <sup>2</sup>
Weight	= 0.73 kg/m
Alloy	EN AW-6060

Technical data	
$I_x$	= 4.15 cm <sup>4</sup>
$I_y$	= 1.26 cm <sup>4</sup>
$W_x$	= 2.07 cm <sup>3</sup>
$W_y$	= 1.18 cm <sup>3</sup>
Cross-section area	= 2.79 cm <sup>2</sup>
Weight	= 0.75 kg/m
Alloy	EN AW-6060

Order data	Order number
20x20 base extrusion	
Standard length 5000 mm	D01-5-5M
20x20 base extrusion	
Cut to length	D01-5-02-02/...
Extra machining	<a href="#">Pages 24-46</a>

Order data	Order number
20x20 corner extrusion	
Standard length 5000 mm	D01-3-5M
20x20 corner extrusion	
Cut to length	D01-3-02-02/...
Extra machining	<a href="#">Pages 24-46</a>

Order data	Order number
20x20 face extrusion	
Standard length 5000 mm	D01-8-5M
20x20 face extrusion	
Cut to length	D01-8-02-02/...
Extra machining	<a href="#">Pages 24-46</a>

Order data	Order number
20x20 Softline extrusion	
Standard length 5000 mm	D03-8-5M
20x20 Softline extrusion	
Cut to length	D03-8-02-02/...
Extra machining	<a href="#">Pages 24-46</a>

Order data	Order number
20x40 base extrusion	
Standard length 5000 mm	D01-7-5M
20x40 base extrusion	
Cut to length	D01-7-02-02/...
Extra machining	<a href="#">Pages 24-46</a>

Order data	Order number
20x40 face extrusion	
Standard length 5000 mm	D02-8-5M
20x40 face extrusion	
Cut to length	D02-8-02-02/...
Extra machining	<a href="#">Pages 24-46</a>

### Face extrusion 20x50 type D02-5

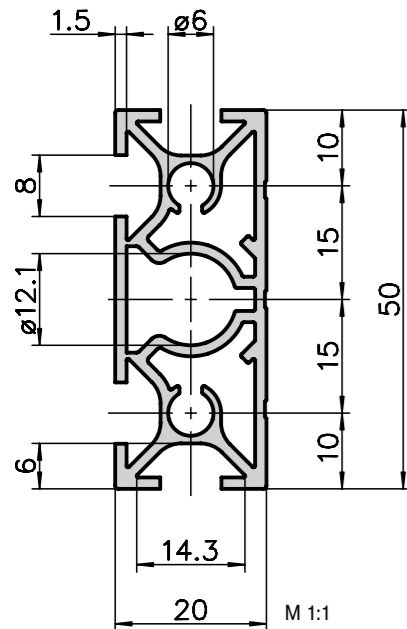

**Application**  
With this combination extrusion 20x50mm, the 20 series extrusion cross-sections can be easily connected to the 50 series ones. The large centre allows a connector of the 20 base with ø12.1 to be fitted

**Application**  
This 20x100mm extrusion is lightweight and nevertheless very sturdy when positioned on its edge. Used in the construction of apparatus racks if closed faces are required. Can also be used as skirting boards along passages.

### Face extrusion 20x100 type D02-1

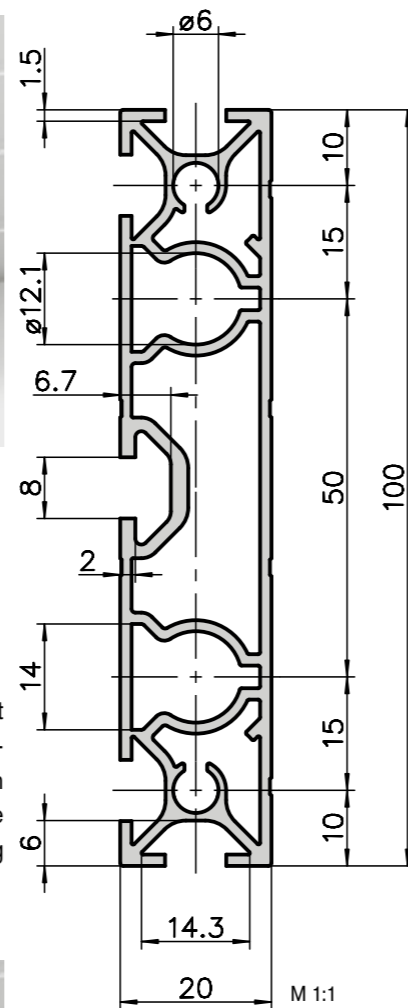

**Technical data**

$I_x$	=	55.5 cm <sup>4</sup>
$I_y$	=	3.01 cm <sup>4</sup>
$W_x$	=	11.1 cm <sup>3</sup>
$W_y$	=	3.01 cm <sup>3</sup>
Cross-section area	=	5.7 mm <sup>2</sup>
Weight	=	1.55 kg/m
Alloy	=	EN AW-6063

**Order data**

Face extrusion 20x100	Order number
Standard length 5000 mm	D02-1-5M
Face extrusion 20x100	
Cut to length	D02-1-02-02/...
Extra machining	<a href="#">Pages 24-46</a>

**Technical data**

$I_x$	=	7.71 cm <sup>4</sup>
$I_y$	=	1.58 cm <sup>4</sup>
$W_x$	=	3.08 cm <sup>3</sup>
$W_y$	=	1.58 cm <sup>3</sup>
Cross-section area	=	3.25 cm <sup>2</sup>
Weight	=	0.88 kg/m
Alloy	=	EN AW-6063

**Order data**

Face extrusion 20x50mm	Order number
Standard length 5000 mm	D02-5-5M
Face extrusion 20x50mm	
Cut to length	D02-5-02-02/...
Extra machining	<a href="#">Pages 24-46</a>

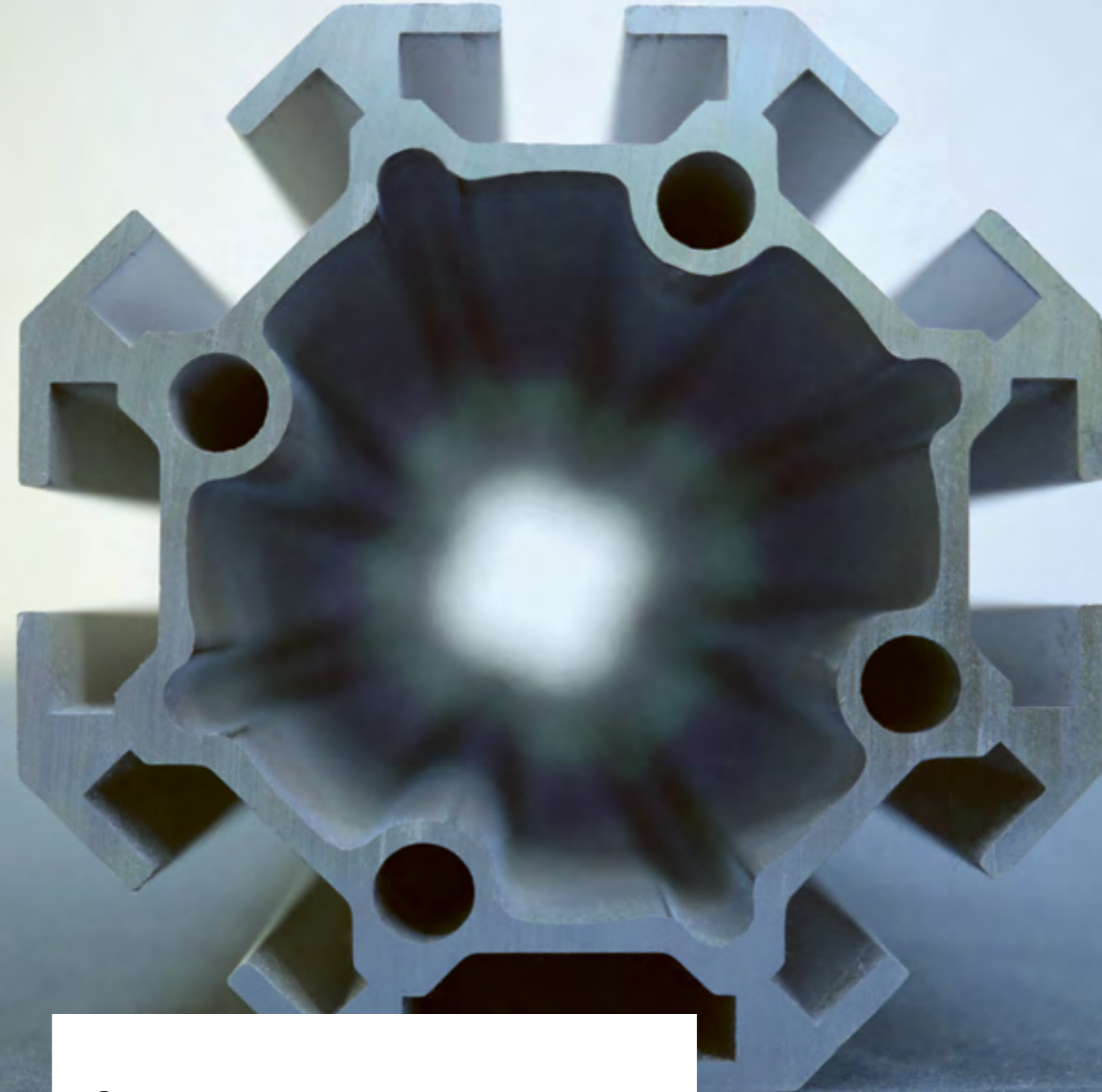
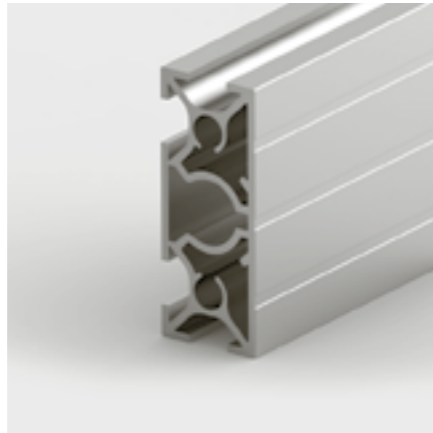

## Special extrusions

### Wall rail 18x50 type A19-9

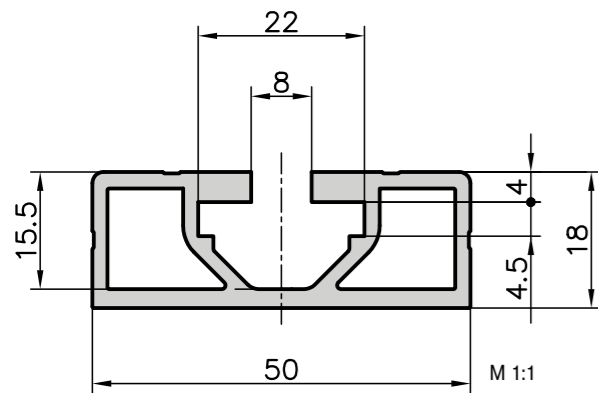

#### Application

This is a very slim extrusion. When screwed to walls, it provides an easy method of fixing adjustable shelves.

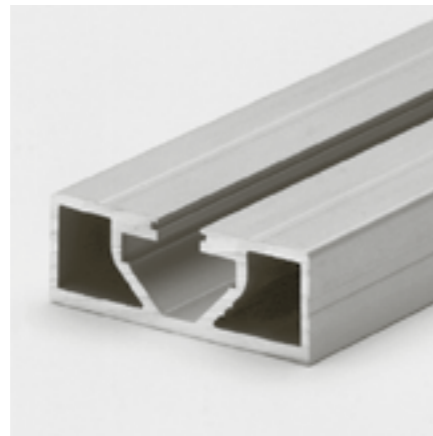

#### Technical data

Cross-section area	=	3.47 cm <sup>2</sup>
Weight	=	0.9 kg/m
Alloy		EN AW-6063

#### Order data      Order number

Wall rail 18x50	
Standard length 5000 mm	A19-9-5M
Wall rail 18x50	
Cut to length	A19-9-02-02/...

### Slot extrusion 16x40 type C08-1

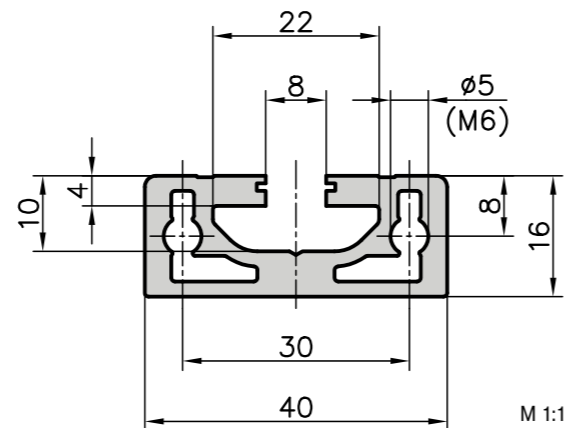

#### Application

A robust rail with the slot geometry of the 40 base. The slot base is solid in order to accommodate the thread holes. When fixed to walls with dowels, height adjustable shelves can be very easily attached to this extrusion rail.

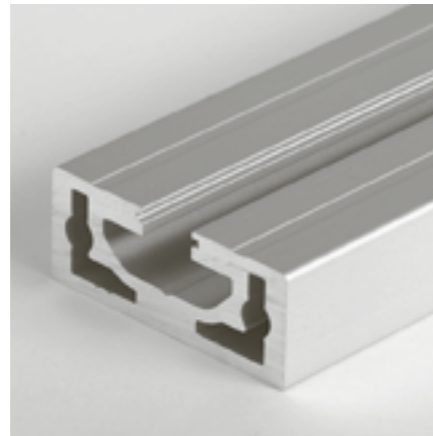

#### Technical data

Cross-section area	=	3.55 cm <sup>2</sup>
Weight	=	1.0 kg/m
Alloy		EN AW-6063

#### Order data      Order number

Slot extrusion 16x40	
Standard length 5000 mm	C08-1-5M
Slot extrusion 16x40	
Cut to length	C08-1-02-02/...

### Slot extrusion 16x40 Type B19-4

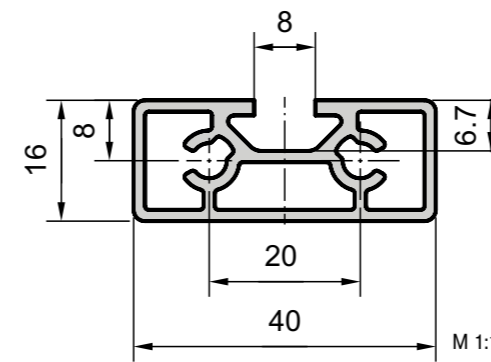

#### Application

The slot extrusion has a standard base 30 and the core hole spacing is selected so that the screw heads do not protrude laterally with countersunk screws (M5), so that a surface, for example, can be attached elegantly at the side.

#### Technical data

Cross-section area	=	2.45 cm <sup>2</sup>
Weight	=	0.66 kg/m
Alloy		EN AW-6063

#### Order data      Order number

Slot extrusion 16x40	
Standard length 5000 mm	B19-4-5M
Slot extrusion 16x40	
Cut to length	B19-4-02-02/...

### Wall rail 20x120 Type C08-4

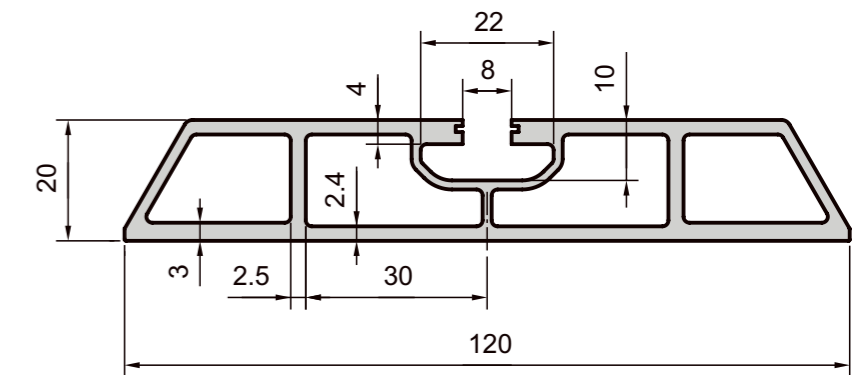

#### Application

As the name suggests, this cross-section is often screwed to a wall so that installations can be attached to the central groove. Grey end caps are available for the open ends.



#### Technical data

Cross-section area	=	7.7 cm <sup>2</sup>
Weight	=	2.1 kg/m
Alloy		EN AW-6063

#### Order data      Order number

Wall rail 20x120	
Standard length 5000 mm	C08-4-5M
Wall rail 20x120	
Cut to length	C08-4-02-02/...

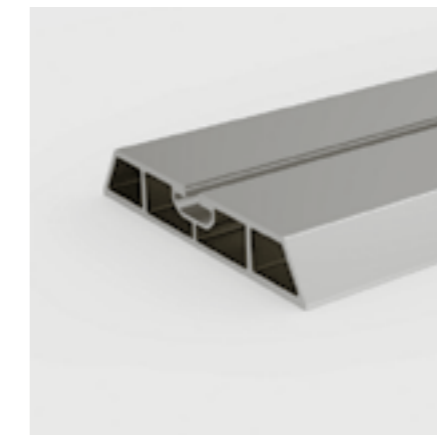

### 20x80 slot extrusion type C08-2

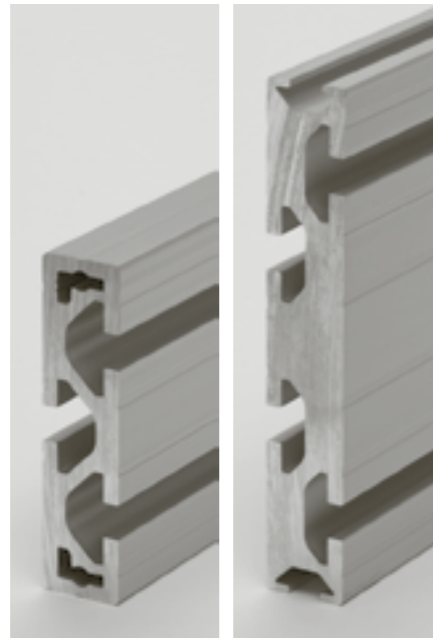
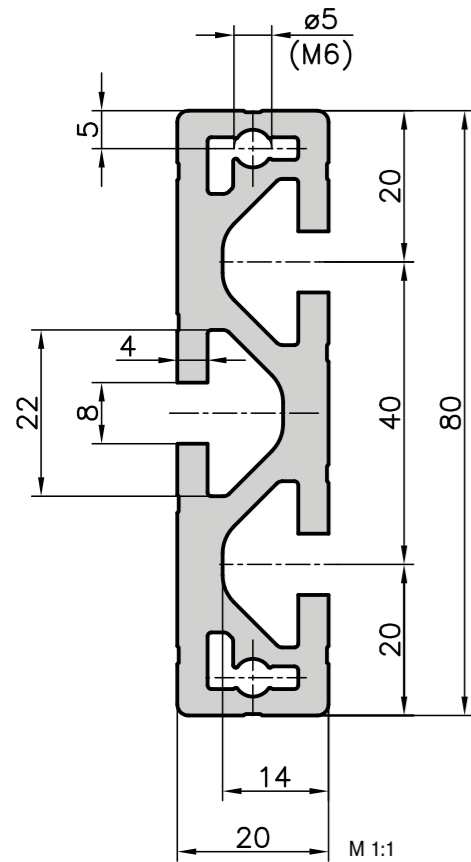

#### Application

These slot extrusions are very versatile and can be used as a floor or adapter-plate, for heavy duty guidance, distance-holder as well as for fixing plates, etc.

### 20x120 slot extrusion type C08-3

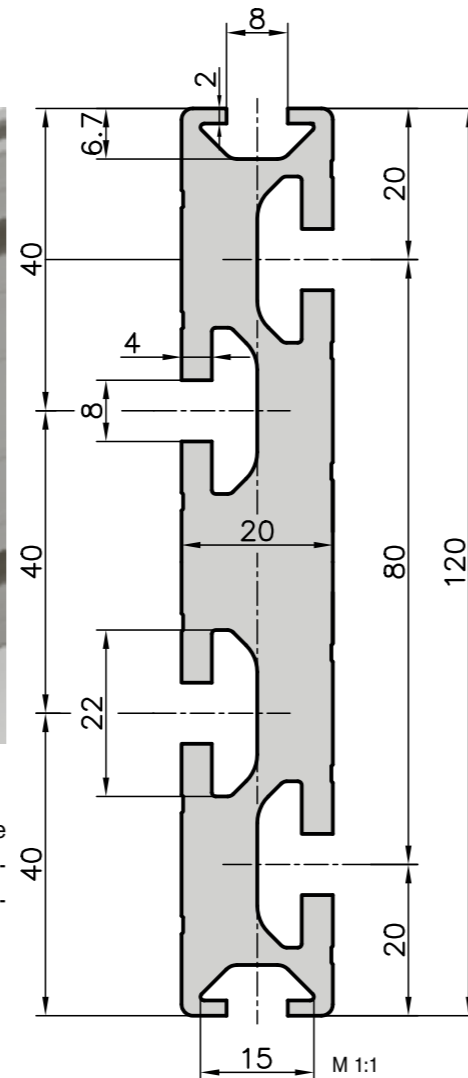

#### Technical data

I <sub>x</sub>	=	177.95 cm <sup>4</sup>
I <sub>y</sub>	=	6.31 cm <sup>4</sup>
W <sub>x</sub>	=	29.66 cm <sup>3</sup>
W <sub>y</sub>	=	6.31 cm <sup>3</sup>
Cross-section area	=	16.40 cm <sup>2</sup>
Weight	=	4.42 kg/m
Alloy	=	EN AW-6063

#### Order data

20x120 slot extrusion	
Standard length 5000 mm	C08-3-5M
20x120 slot extrusion	
Cut to length	C08-3-02-02/...

### 30x15 triple channel extrusion type B05-1

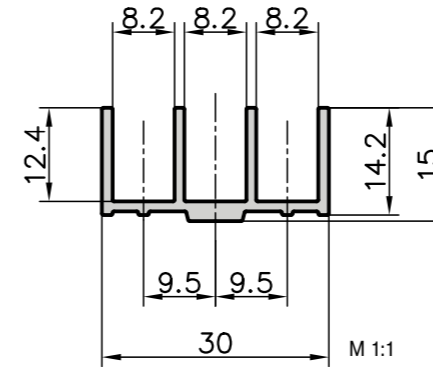

#### Application

A screw-on extrusion which is ideal for inserting panels, glazing and sliding doors, or any application requiring an attractive finish with functional reliability. The triple channel extrusion can slide onto standard extrusions with the base 30 mm. The plastic extrusions B39-55 and B39-35 (page 98) can be used to improve the sliding properties, to reduce the size of the slots or as clip-on covers.

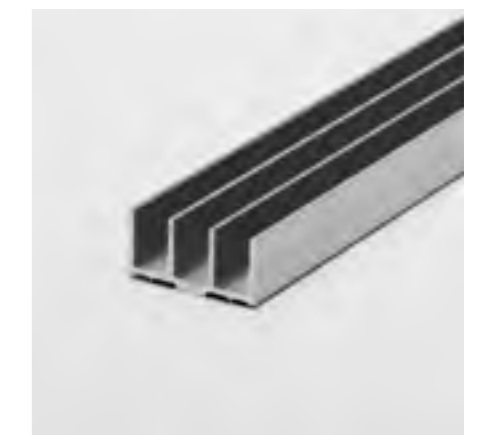
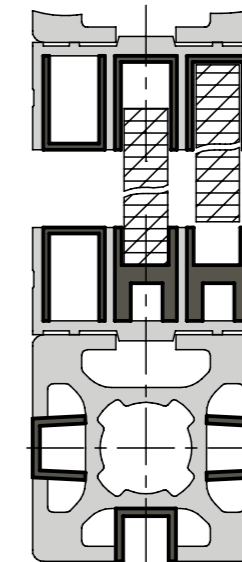

#### Technical data

Cross-section area	=	1.18 cm <sup>2</sup>
Weight	=	0.32 kg/m
Alloy	=	EN AW-6060

#### Order data

30x15 triple channel extrusion	
Standard length 5000 mm	B05-1-5M
30x15 triple channel extrusion	
Cut to length	B05-1-02-02/...

#### Technical data

I <sub>x</sub>	=	54.49 cm <sup>4</sup>
I <sub>y</sub>	=	3.97 cm <sup>4</sup>
W <sub>x</sub>	=	13.62 cm <sup>3</sup>
W <sub>y</sub>	=	3.97 cm <sup>3</sup>
Cross-section area	=	8.90 cm <sup>2</sup>
Weight	=	2.4 kg/m
Alloy	=	EN AW-6063

#### Order data

20x80 slot extrusion	
Standard length 5000 mm	C08-2-5M
20x80 slot extrusion	
Cut to length	C08-2-02-02/...

### 3-fold roller guide Type B06-3

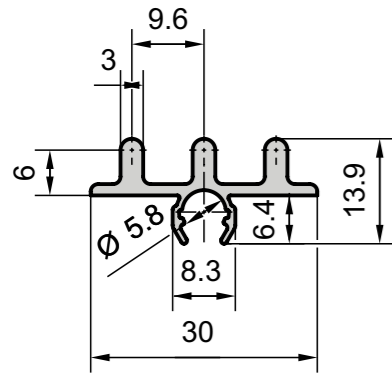

**Application**  
The roller guide is ideal for glass sliding doors. Three sliding doors on rollers can be realised in the smallest of spaces. The profile is simply clipped into the support profiles for fastening.

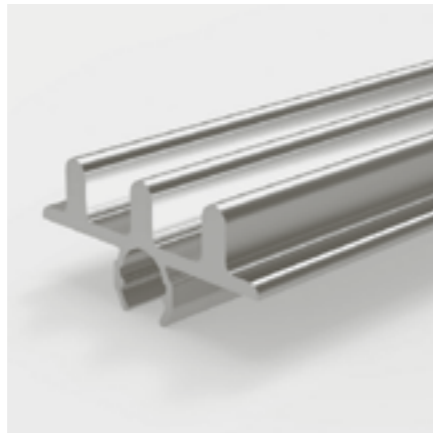

**Technical data**

Cross-section area = 1.08 cm<sup>2</sup>  
Weight = 0.30 kg/m  
Alloy EN AW-6060

**Order data Order number**

3-fold roller guide  
Standard length 5000 mm B06-3-5M  
3-fold roller guide  
Cut to length B06-3-02-02/...



### Glass rail 5 mm Type B06-4

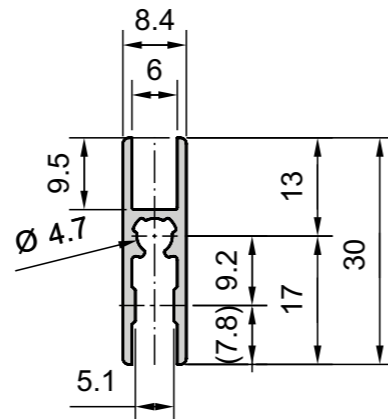

**Application**  
The glass rail can accommodate surfaces up to a thickness of 6.0 mm in the upper area. These are glued into the groove base. In the lower area, the filigree profile has a thickening to accommodate rollers. Together with the roller guide profile, smooth-running sliding doors can be realised in confined spaces.

**Technical data**

Cross-section area = 0.91 cm<sup>2</sup>  
Weight = 0.25 kg/m  
Alloy EN AW-6060

**Order data Order number**

Glass rail 5 mm  
Standard length 5000 mm B06-4-5M  
Glass rail 5 mm  
Cut to length B06-4-02-02/...

### 19" auxiliary extrusion type A05-2

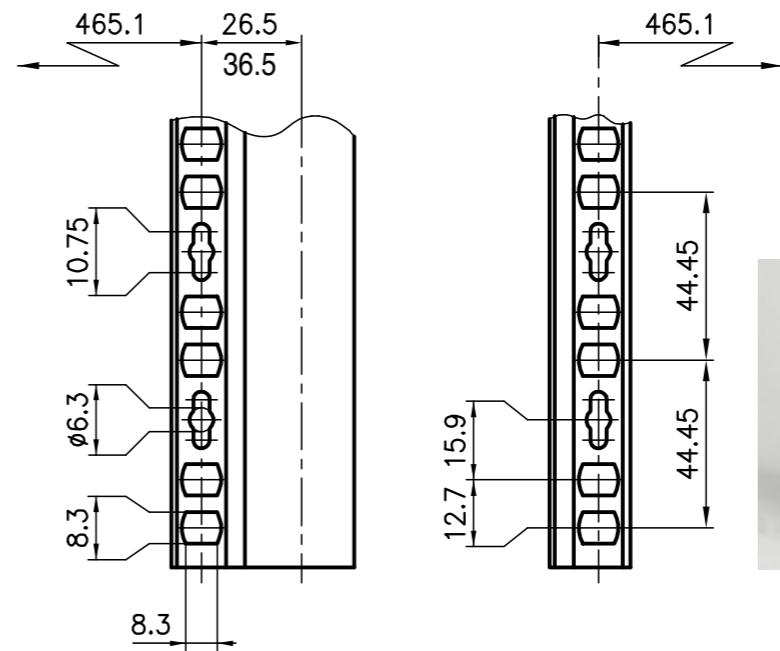
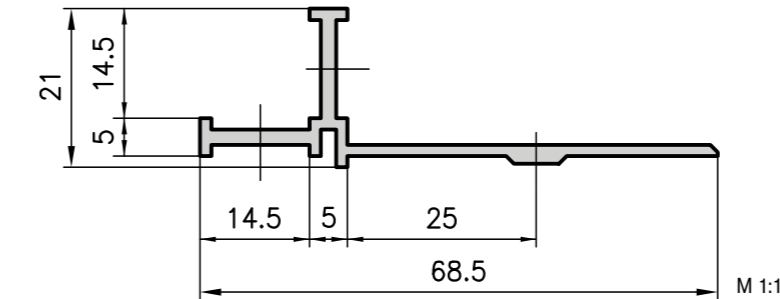

**Technical data**

Cross-section area = 1.67 cm<sup>2</sup>  
Weight = 0.5 kg/m  
Alloy EN AW-6060

**Order data Order number**

19" auxiliary extrusion  
Standard length 5000 mm A05-2-5M  
19" auxiliary extrusion  
Cut to length A05-2-02-02/...

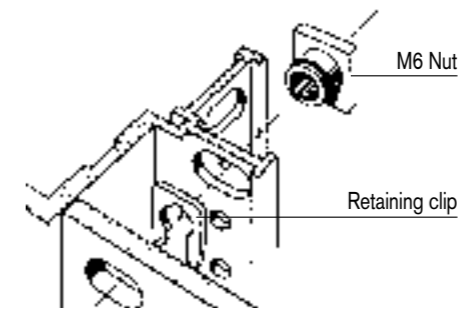

**Order data Order number**

Retaining clip H2-506  
Special M6 nut H2-504

### 19" auxiliary extrusion type B05-2

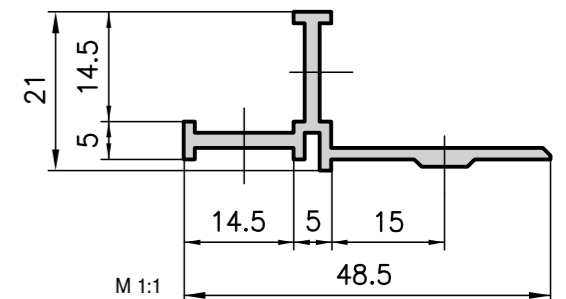

**Application**  
The screw-on extrusion allows 19" racking to be incorporated into electronic, pneumatic and hydraulic applications. This specially punched rail can be bolted onto any standard design extrusion with a base of 50 or 30 mm. It meets the requirements of IEC297. Equipment is easy to install using M6 nuts and retaining clips.



**Technical data**

Cross-section area = 1.37 cm<sup>2</sup>  
Weight = 0.4 kg/m  
Alloy EN AW-6060

**Order data Order number**

19" auxiliary extrusion  
Standard length 5000 mm B05-2-5M  
19" auxiliary extrusion  
Cut to length B05-2-02-02/...

### 30x95 box frame extrusion type B01-7

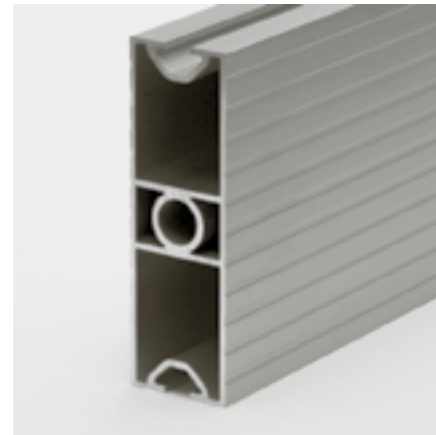
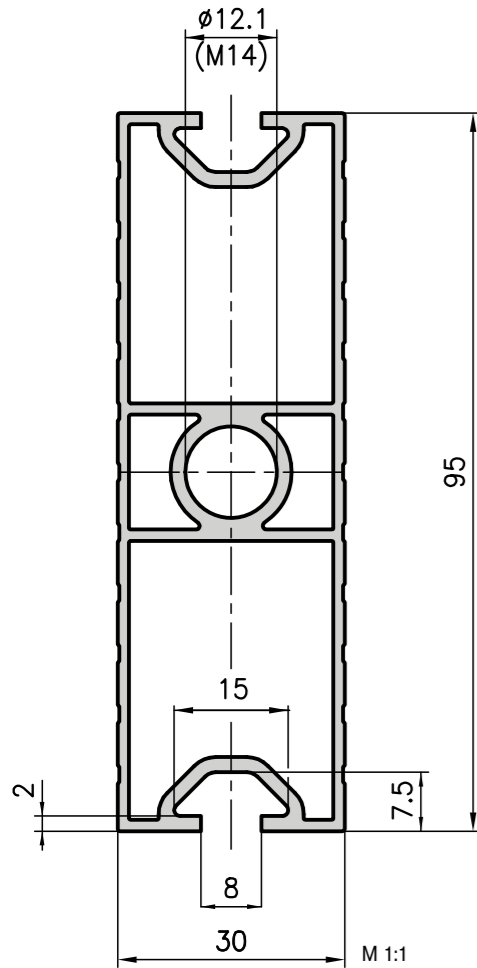

#### Application

The basic material for the single and double wheeled runner (see [page 90](#)). However, it can also be used as a frame extrusion to hold thick panels in place.

### 30x50 runner extrusion type B10-9

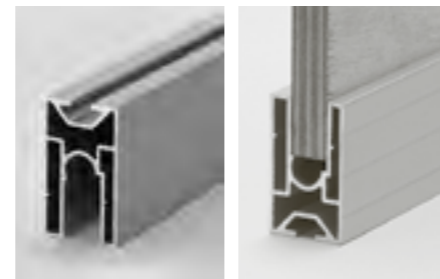
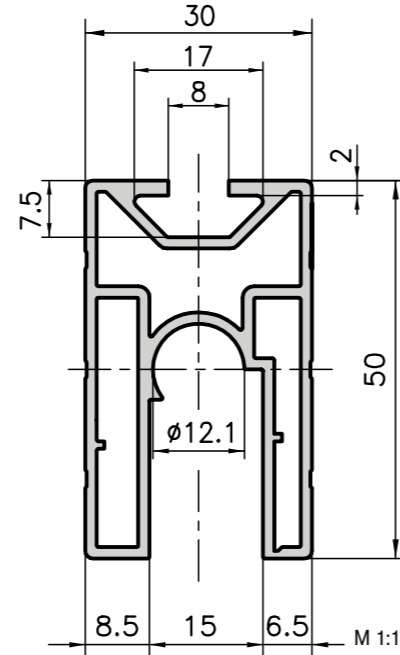

#### Technical data

I <sub>x</sub>	=	9.17 cm <sup>4</sup>
I <sub>y</sub>	=	4.51 cm <sup>4</sup>
W <sub>x</sub>	=	3.37 cm <sup>3</sup>
W <sub>y</sub>	=	2.98 cm <sup>3</sup>
Cross-section area	=	3.94 cm <sup>2</sup>
Weight	=	1.1 kg/m
Alloy	=	EN AW-6063

#### Order data

Order data	Order number
30x50 runner extrusion	
Standard length 5000 mm	B10-9-5M
30x50 runner extrusion	
Cut to length	B10-9-02-02/...

### 30x15 frame extrusion type B15-1

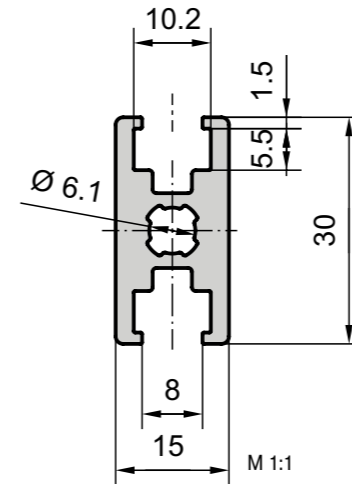

#### Application

This very slim and lightweight extrusion can be connected to the fastening elements of base 20.

A standard M6 nut can be used as a sliding block or an M6 6Kt screw as a T-screw.

#### Technical data

I <sub>x</sub>	=	1.4 cm <sup>4</sup>
I <sub>y</sub>	=	0.71 cm <sup>4</sup>
W <sub>x</sub>	=	0.933 cm <sup>3</sup>
W <sub>y</sub>	=	0.473 cm <sup>3</sup>
Cross-section area	=	244.9 mm <sup>2</sup>
Weight	=	0.66 kg/m
Alloy	=	EN AW-6063

#### Order data

Order data	Order number
Standard length 5000 mm	B15-1-5M
Cut to length	B15-1-02-02/...

### 30 mm base octagonal extrusion type B15-3

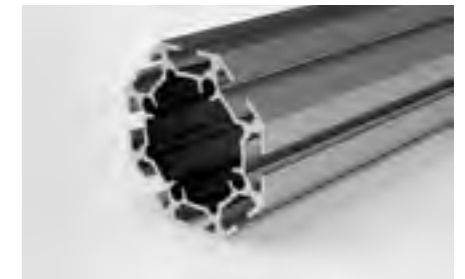
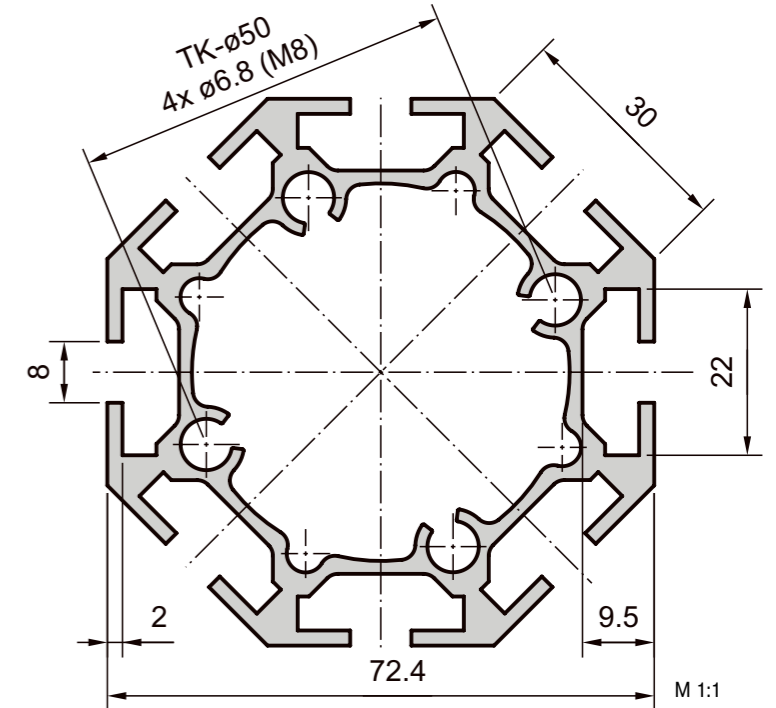

#### Application

Ideal for large, heavy duty machine enclosures in a round design, and as an axial extrusion for rotating structures. It can also have base plates bolted on and be used as a support extrusion.

An elegant extrusion for interior decoration such as tables, carriages, etc.

#### Technical data

I <sub>x, y</sub>	=	50.5 cm <sup>4</sup>
W <sub>x, y</sub>	=	14.02 cm <sup>3</sup>
Cross-section area	=	9.93 mm <sup>2</sup>
Weight	=	2.7 kg/m
Alloy	=	EN AW-6063

#### Order data

Order data	Order number
30 mm base octagonal extrusion	
Standard length 5000 mm	B15-3-5M
30 mm base octagonal extrusion	
Cut to length	B15-3-02-02/...
Extra machining	<a href="#">Pages 24-46</a>

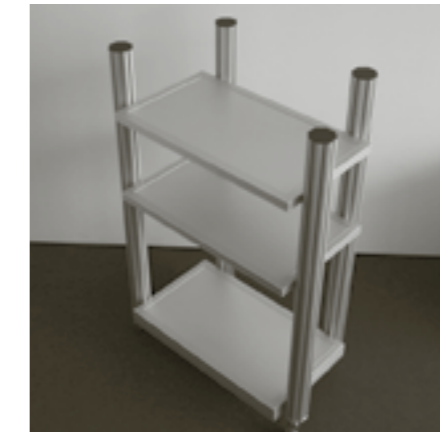

#### Technical data

I <sub>x</sub>	=	55.99 cm <sup>4</sup>
I <sub>y</sub>	=	7.94 cm <sup>4</sup>
W <sub>x</sub>	=	11.79 cm <sup>3</sup>
W <sub>y</sub>	=	5.29 cm <sup>3</sup>
Cross-section area	=	6.54 cm <sup>2</sup>
Weight	=	1.8 kg/m
Alloy	=	EN AW-6060

#### Order data

Order data	Order number
30x95 box frame extrusion	
Standard length 5850 mm	B01-7-5.85M
30x95 box frame extrusion	
Cut to length	B01-7-02-02/...



Extra machining

[Pages 24-46](#)



### 16x50 double clamping extrusion type A05-7

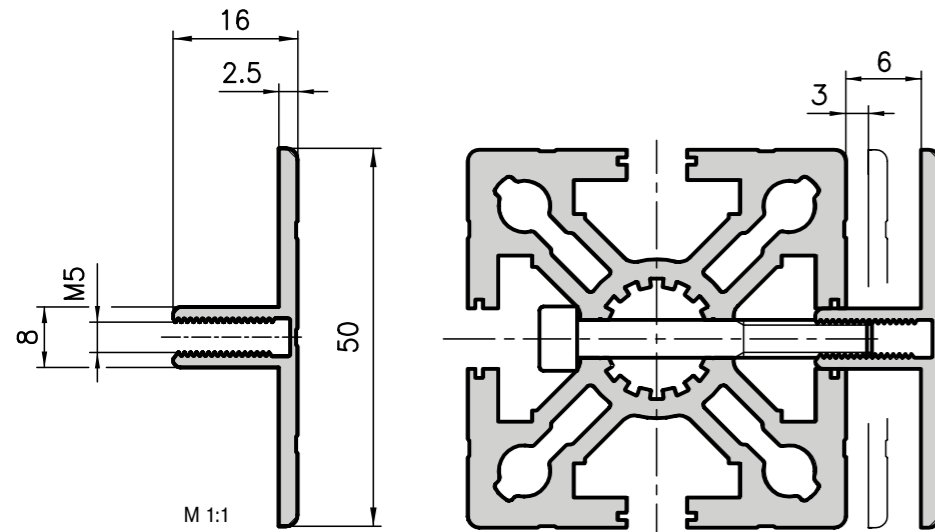

#### Application

Two ingenious extrusions to clamp panels of all kinds. They can be added to any existing 8 mm slots on extrusions base 40, 45 or 50 mm. Panels can be inserted or replaced easily, on one or two of the sides, without any need to dismantle the supporting structure!

#### Technical data

Cross-section area	=	1.70 cm <sup>2</sup>
Weight	=	0.46 kg/m
Alloy		EN AW-6063

#### Order data Order number

16x50 double clamping extrusion	
Standard length 5000 mm	A05-7-5M
16x50 double clamping extrusion	
Cut to length	A05-7-02-02/...



### Panel clamp extrusions type A05-8/C05-8

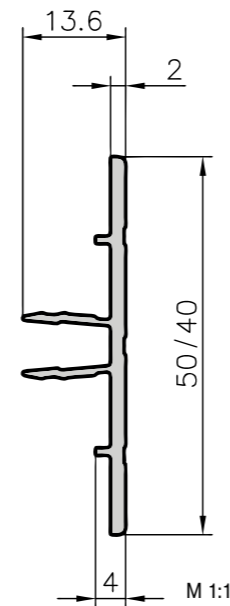

#### Application

Similar to the clamping extrusion but with the additional benefit, that this extrusion can be clipped in. Ideal for ALUCOBOND- and DIBOND- panels or other sheets with a thickness of 2mm and respectively 4 mm (2 snap-in positions for clamping!)

#### Technical data

Cross-section area	=	1.26 cm <sup>2</sup>
Weight	=	0.34 kg/m
Alloy		EN AW-6060

#### Order data Order number

13.5x50 panel clamp extrusion	
Standard length 6000 mm	A05-8-6M
13.5x50 panel clamp extrusion	
Cut to length	A05-8-02-02/...
13.6x40 panel clamp extrusion	
Standard length 6000 mm	C05-8-6M
13.6x40 panel clamp extrusion	
Cut to length	C05-8-02-02/...

### 8x13.5 U-clamping extrusion type B19-6

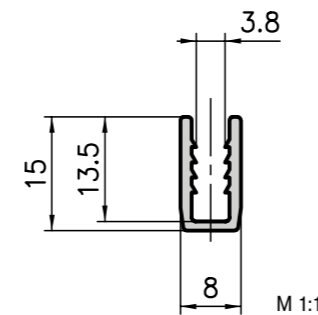

#### Application

A special extrusion for clamping the wire mesh. The U-extrusion fits into all extrusions with a base of 50, 40 and 30 mm.

#### Technical data

Cross-section area	=	0.53 cm <sup>2</sup>
Weight	=	0.14 kg/m
Alloy		EN AW-6060

#### Order data Order number

8x13.5 U-clamping extrusion	
Standard length 5000 mm	B19-6-5M
8x13.5 U-clamping extrusion	
Cut to length	B19-6-02-02/...

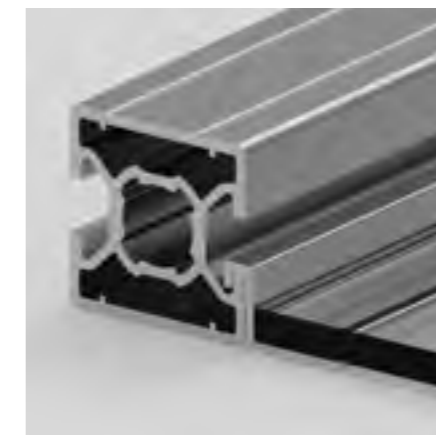

### Suspension extrusion base 30 / base 50

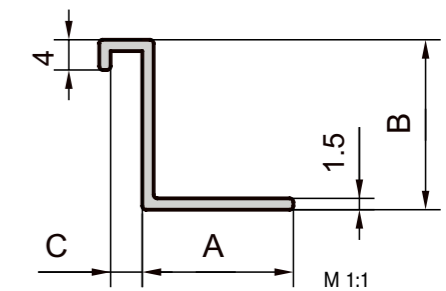

#### Measurements

Type	Base	A	B	C
S91-013	30	16.5	12.5	2.2
S91-014	50	20.0	22.5	4.0

#### Application

The suspension extrusion for aluminium extrusion of the base 30 and 50 is flush with the extrusion. It is used for supporting surface elements such as glass, etc. No fixing screws are required for this. No fixing screws are required for this as the panel elements are simply laid on top.

#### Technical data

Cross-section area	=	0.5 cm <sup>2</sup>
Weight	=	0.14 kg/m
Alloy		EN AW-6063

#### Order data Order number

Suspension extrusion base 30	
Standard length 5000 mm	S91-013
Suspension extrusion base 30	
Cut to length	S91-013-02-02/...
Suspension extrusion base 50	
Standard length 5000 mm	S91-014
Suspension extrusion base 50	
Cut to length	S91-014-02-02/...

### 11x30.5 support extrusion type B19-7

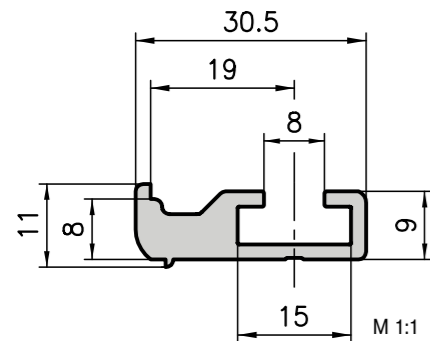

#### Application

A special extrusion for clamping the wire mesh. The U-extrusion fits into all extrusions with a base of 50, 45, 40 and 30 mm.

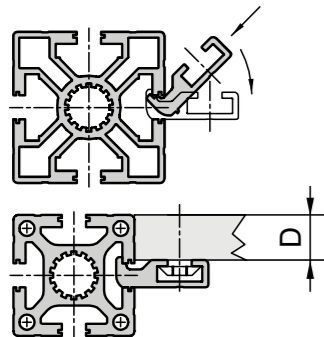

#### Measurement data

Extrusion size	D
Base 30	10
Base 40	15
Base 45	17.5
Base 50	20

#### Technical data

Cross-section area	= 1.62 cm <sup>2</sup>
Weight	= 0.44 kg/m
Alloy	EN AW-6060

#### Order data Order number

11x30.5 stop extrusion	
Standard length 5000 mm	B19-7-5M
11x30.5 stop extrusion	
Cut to length	B19-7-02-02/...

### Aluminium guide extrusion type B19-8

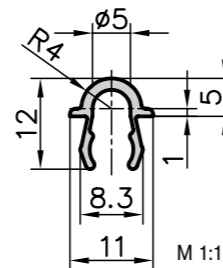

#### Application

This aluminium guide can be easily clipped into all slots of Base 50/45/40/30. With 30 base extrusions, a snap-in function prevents the guide from falling out. With 50/40 base extrusions, the guide is jammed in the slot. If necessary, a steel pin Ø 6 can also be pressed in on the side which prevents any possible movement of the guide. Advantages of this guide are:

- Quick and easy fitting, and inexpensive
- Closed slots reduce the build up of dirt
- Can be retrofitted at any time onto existing structures

Sliding doors are so easy and inexpensive to produce. Used especially in applications where the build up of dirt in an open slot or guide is to be prevented.

This extrusion is primarily used as a running rail for the concave roller.

Wheeled runner, see [Page 64](#).

Alloy EN AW-6060

#### Order data Order number

<b>Aluminium guide extrusion</b>	
Standard length 5000 mm	B19-8-5M
Cut to length	B19-8-02-02/...

### Support extrusion 25x25 Type B05-5

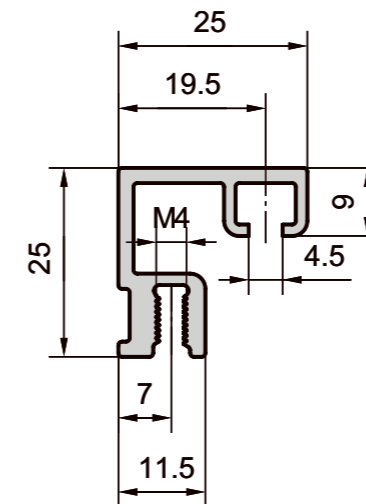

#### Application

The support extrusion is screwed onto a extrusion of the base 40 using stepped holes, thus forming a circumferential stop frame. Surfaces can now be screwed directly onto the integrated screw channel.

#### Technical data

Cross-section area	= 1.77 cm <sup>2</sup>
Weight	= 0.48 kg/m
Alloy	EN AW-6060

#### Order data Order number

Support extrusion 25x25	
Standard length 5000 mm	B05-5-5M
Support extrusion 25x25	
Cut to length	B05-5-02-02/...

### Frame extrusion 27x30 Type B05-6

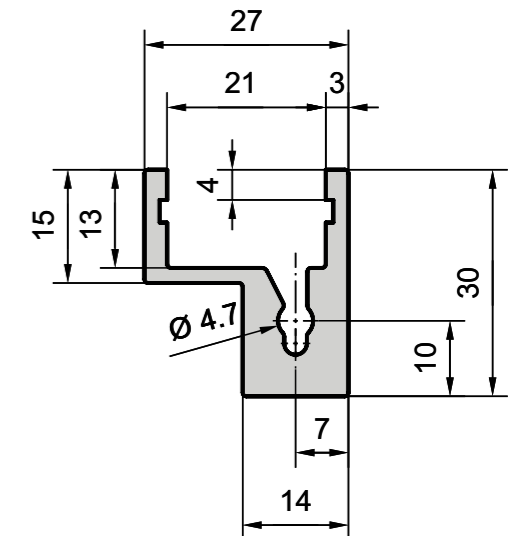

#### Application

The frame extrusion can be provided with stepped holes in the corners to form a stable frame for holding panel elements. The panel elements are inserted with the clamping sealing rubber. Together with the B05-5 support extrusion and the matching seal, the profile shape forms an attractive finish. For screwed surfaces, the frame extrusion is designed with a stepped hole and fixed directly to the screw channel of the B05-5.

#### Technical data

Cross-section area	= 2.91 cm <sup>2</sup>
Weight	= 0.79 kg/m
Alloy	EN AW-6060

#### Order data Order number

Frame extrusion 27x30	
Standard length 5000 mm	B05-6-5M
Frame extrusion 27x30	
Cut to length	B05-6-02-02/...

### Angle extrusion type A30-0/C30-0

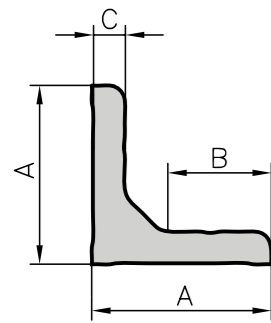

**Measurement data**

Type	A	B	C
A30-0	38	21	8
C30-0	31	17	6

**Technical data**

	A30-0	C30-0
Cross-section area	= 5.52 cm <sup>2</sup>	3.46 cm <sup>2</sup>
Weight	= 1.49 kg/m	0.94 kg/m
Alloy	EN AW-6060	

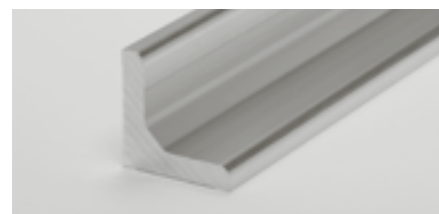

**Order data**

Order data	Order number
Angle extrusion raw 38x38	A30-0-3M
Standard length 3000 mm	
Angle extrusion raw 38x38	
Cut to length	A30-0-02-02/...
Angle extrusion raw 31x31	
Standard length 3000 mm	C30-0-3M
Angle extrusion raw 31x31	
Cut to length	C30-0-02-02/...

### Angle extrusion type A30-2

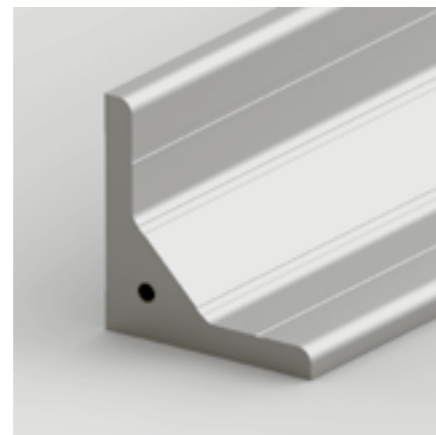
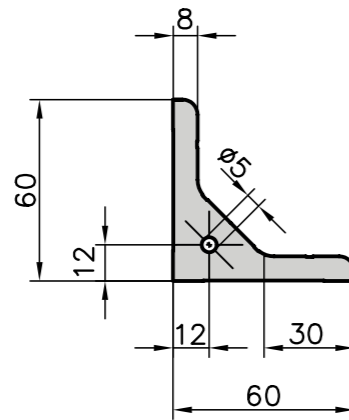

**Technical data**

Cross-section area	= 10.15 cm <sup>2</sup>
Weight	= 2.75 kg/m
Alloy	EN AW-6060

**Order data**

Order data	Order number
Angle extrusion raw 60x60	A30-2-3M
Standard length 3000 mm	
Angle extrusion raw 60x60	
Cut to length	A30-2-02-02/...

### Angle extrusion type C30-3

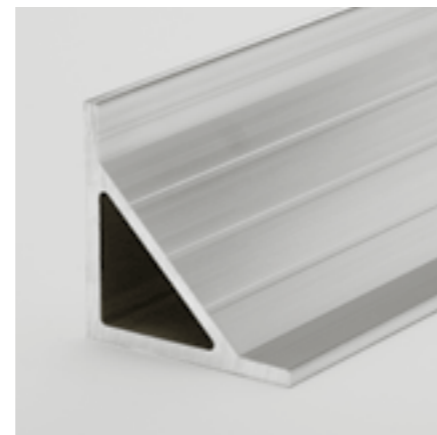
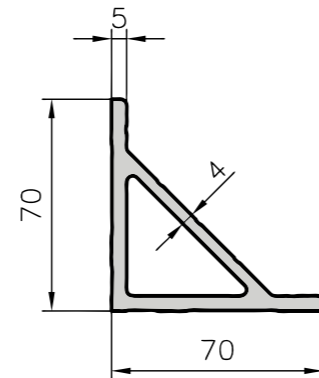

**Technical data**

Cross-section area	= 9.23 cm <sup>2</sup>
Weight	= 2.49 kg/m
Alloy	EN AW-6060

**Order data**

Order data	Order number
Angle extrusion raw 70x70	C30-3-3M
Standard length 3000 mm	
Angle extrusion raw 70x70	
Cut to length	C30-3-02-02/...

### Angle extrusion type E30-3

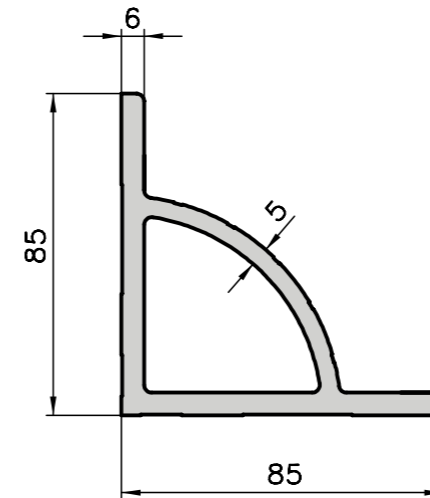

**Application**

This angle extrusion is the starting material for mounting brackets for the base 45 products. The support arch with the Kanya shadow slots appears very elegant.

**Technical data**

Cross-section area	= 13.44 cm <sup>2</sup>
Weight	= 3.70 kg/m
Alloy	EN AW-6060

**Order data**

Order data	Order number
Angle extrusion raw 85x85	E30-3-3M
Standard length 3000 mm	
Angle extrusion raw 85x85	
Cut to length	E30-3-02-02/...

### Angle extrusion type A30-4

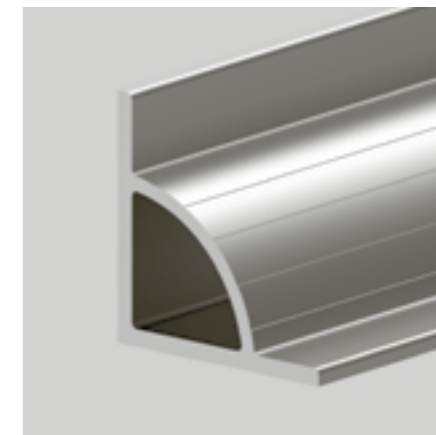
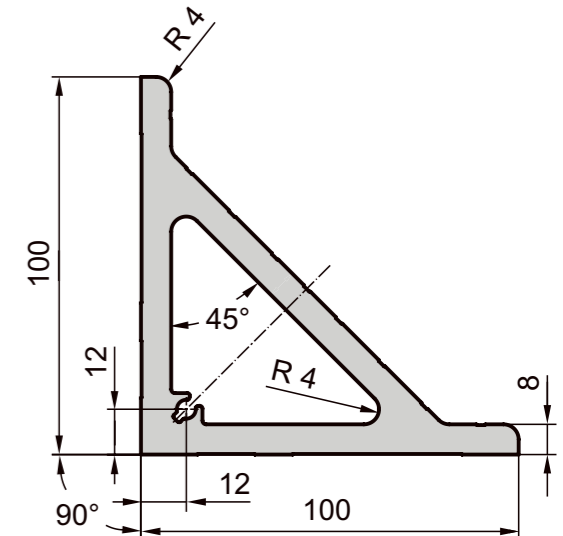

**Application**

These very strong angle extrusions are the source material for the mounting brackets. They're also used to reinforce heavily loaded constructions.

**Technical data**

Cross-section area	= 23.63 cm <sup>2</sup>
Weight	= 6.38 kg/m
Alloy	EN AW-6060

**Order data**

Order data	Order number
Angle extrusion raw 100x100	A30-4-3M
Standard length 3000 mm	
Angle extrusion raw 100x100	
Cut to length	A30-4-02-02/...

### Angle extrusion type A47-0

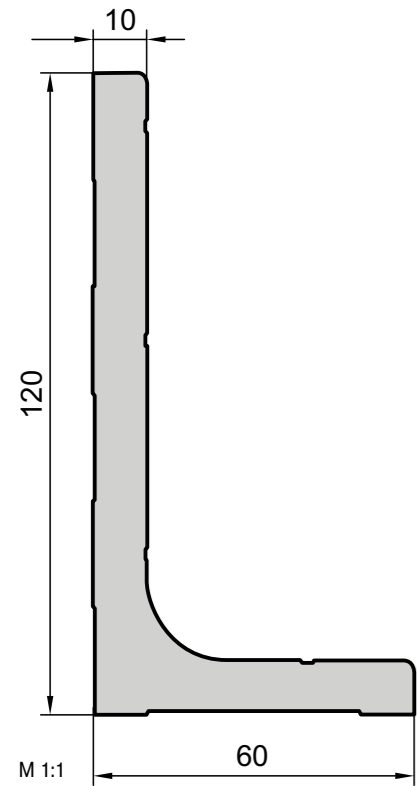

**Application**  
Source material for floor bolting brackets or for reinforcements.

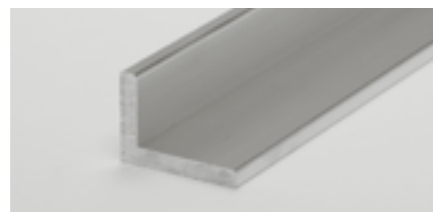
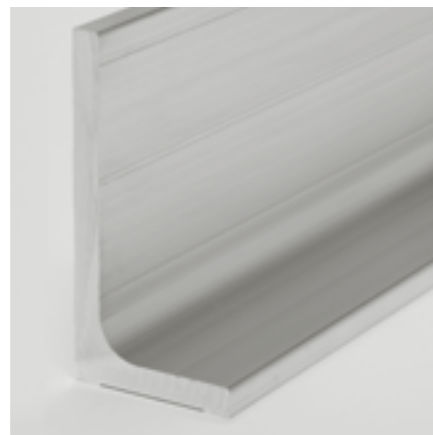

**Technical data**

Cross-section area	= 17.15 cm <sup>2</sup>
Weight	= 4.63 kg/m
Alloy	EN AW-6060

**Order data**      **Order number**

Angle extrusion raw 60x120	
Standard length 3600 mm	A47-0-3.6M
Angle extrusion raw 60x120	
Cut to length	A47-0-02-02/...

### Angle extrusion type A30-5

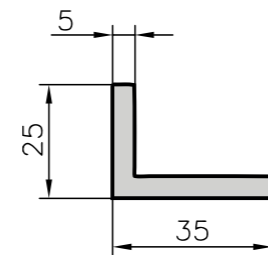

**Application**  
Source material for mounting and fixing brackets or as support bracket.

**Technical data**

Cross-section area	= 2.74 cm <sup>2</sup>
Weight	= 0.74 kg/m
Alloy	EN AW-6060

**Order data**      **Order number**

Angle extrusion raw 25x35	
Standard length 5000 mm	A30-5-5M
Angle extrusion raw 25x35	
Cut to length	A30-5-02-02/...

### Hinge extrusion type A60-6/C60-6

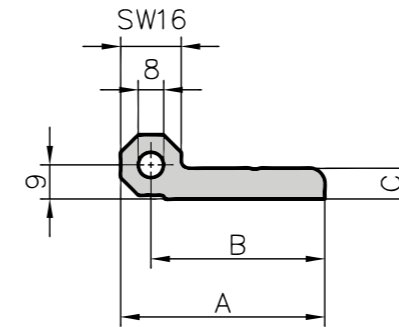

**Measurement data**

Type	A	B	C
A60-6	54	46	8
C60-6	44	36	8

**Application**  
Source material for the unhingable and the heavy duty hinges or for producing special hinges.

**Specification**  
Aluminium raw

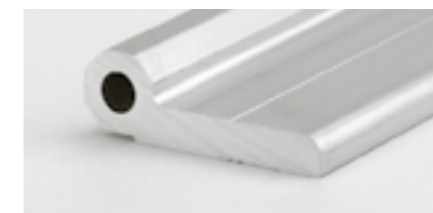

**Technical data**

	A60-6	C60-6
Weight	= 1.33 kg/m	1.11 kg/m
Alloy		EN AW-6060

**Order data**      **Order number**

17x54 hinge extrusion	
Standard length 3000 mm	A60-6-3M
17x54 hinge extrusion	
Cut to length	A60-6-02-02/...
17x44 hinge extrusion	
Standard length 3000 mm	C60-6-3M
17x44 hinge extrusion	
Cut to length	C60-6-02-02/...

### Hinge extrusion type A60-1, A60-2, B60-1, B60-2

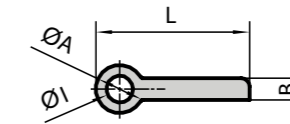

**Measurement data**

Type	L	B	ØA	ØI	kg/m
A60-1	57.5	8	18	10	1.33
B60-1	47.5	8	18	10	1.11
Alloy					EN AW-6063
A60-2	47.0	4	10	6	0.54
B60-2	37.0	4	10	6	0.43
Alloy					EN AW-6060

**Specification**  
Aluminium raw

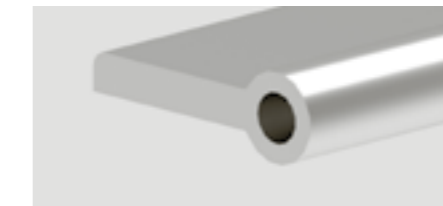

**Order data**      **Order number**

Hinge extrusion	
Standard length 3000 mm	A60-1-3M
Hinge extrusion	
Cut to length	A60-1-02-02/...
Hinge extrusion	
Standard length 3000 mm	B60-1-3M
Hinge extrusion	
Cut to length	B60-1-02-02/...
Hinge extrusion	
Standard length 3000 mm	A60-2-3M
Hinge extrusion	
Cut to length	A60-2-02-02/...
Hinge extrusion	
Standard length 3000 mm	B60-2-3M
Hinge extrusion	
Cut to length	B60-2-02-02/...

### Hinge extrusion type A60-5

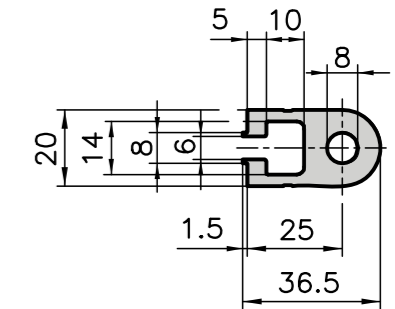

**Application**  
Source material for special hinges or as bearing for simple rotating-mechanism.

**Specification**  
Aluminium anodised

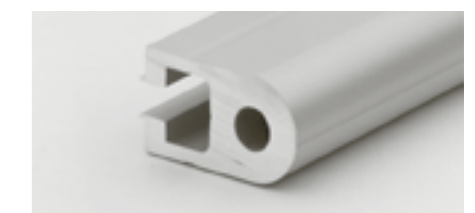

**Technical data**

Weight	=	1.19 kg/m
Alloy		EN AW-6063

**Order data**      **Order number**

20x36.5 hinge extrusion	
Standard length 5000 mm	A60-5-5M
20x36.5 hinge extrusion	
Cut to length	A60-5-02-02/...

### Handle strip extrusion type B65-6

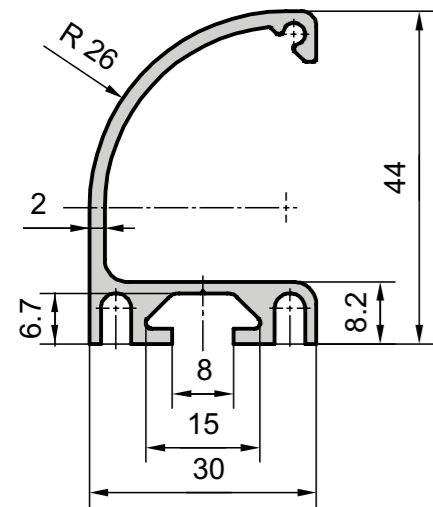

**Application**  
The handle strip can be used as a drawer handle or also as a handle for doors and windows.

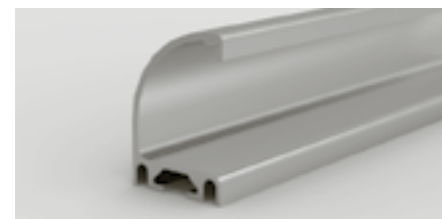

**Technical data**

Cross-section area = 2.37 cm<sup>2</sup>  
Weight = 0.64 kg/m  
Alloy EN AW-6063

**Order data**      **Order number**

Handle strip extrusion 30x44  
Standard length 5000 mm      B65-6-5M

Handle strip extrusion 30x44  
Cut to length      B65-6-02-02/...

### Clamping blocks

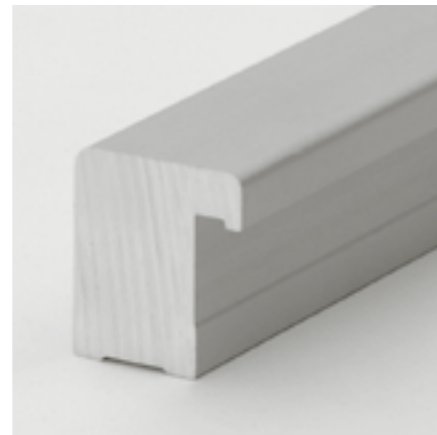
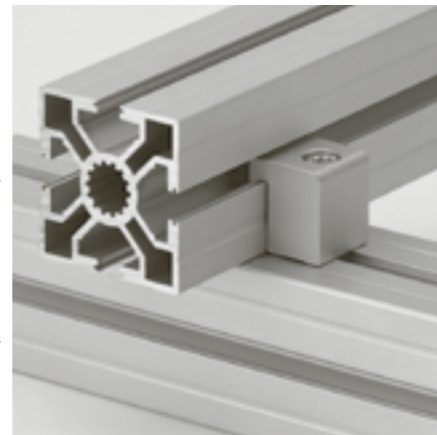
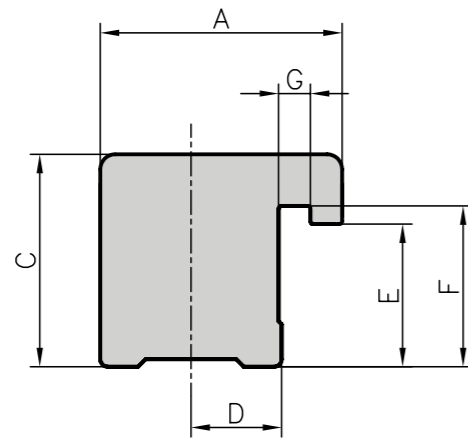

**Application**  
To connect two extrusions of base 50, 40 and 30. A very sturdy cross or parallel connection is produced. Two clamping blocks are required to create the parallel connection.

Clamping blocks machined, see [page 81](#).

Alloy EN AW-6060

**Measurement data**

Type	A	C	D	E	F	G	kg/m
30	17	15	6.5	9.4	10.6	2.1	0.51
40	25	22	10	14.4	15.6	4	1.31
50	25	27	10	19.4	20.6	4	1.58

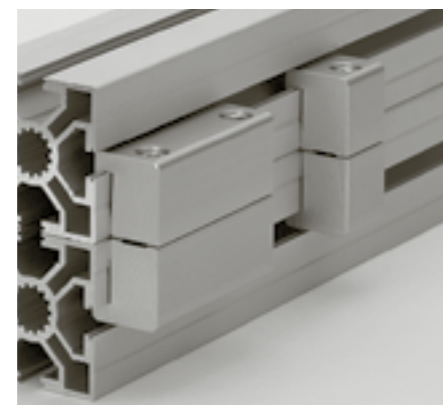

**Order data**      **Order number**

Clamping blocks raw	
<b>Extrusion base 50</b>	
Standard length 3000 mm	A34-0-3M
Cut to length	A34-0-02-02/...
<b>Extrusion base 40</b>	
Standard length 3000 mm	C34-0-3M
Cut to length	C34-0-02-02/...
<b>Extrusion base 30</b>	
Standard length 3000 mm	B34-0-3M
Cut to length	B34-0-02-02/...

### Rectangular tube

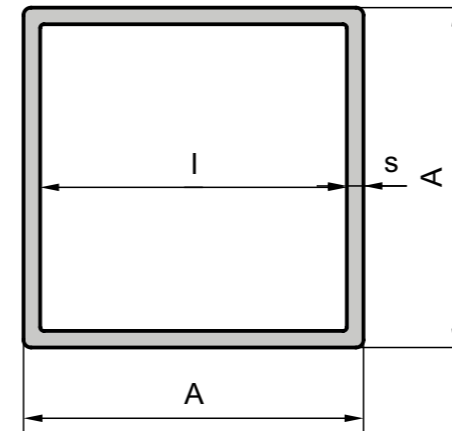

**Application**  
With the rectangular tube and with the combination of the extrusions base 50, 45, 40 und 30 a telescope function can be easily created. Can also be used as a guidance for a counter balance in a construction with a lift gate in addition to many «classic» rectangular tube applications.

**Measurement data**

	I	A	S
A19-5	50.6	55	2.2
C19-5	40.6	45	2.2
B19-5	31	35	2
E19-5	46	50	2

Alloy EN AW-6060

**Technical data**

	A19-5	E19-5	C19-5	B19-5
I <sub>x,y</sub>	21.58 cm <sup>4</sup>	14.75 cm <sup>4</sup>	11.4 cm <sup>4</sup>	4.80 cm <sup>4</sup>
W <sub>x,y</sub>	7.85 cm <sup>3</sup>	5.9 cm <sup>3</sup>	5.06 cm <sup>3</sup>	2.74 cm <sup>3</sup>
Cross-section area	4.64 cm <sup>2</sup>	3.85 cm <sup>2</sup>	3.75 cm <sup>2</sup>	2.64 cm <sup>2</sup>
Weight	1.25 kg/m	1.05 kg	1.02 kg	0.71 kg

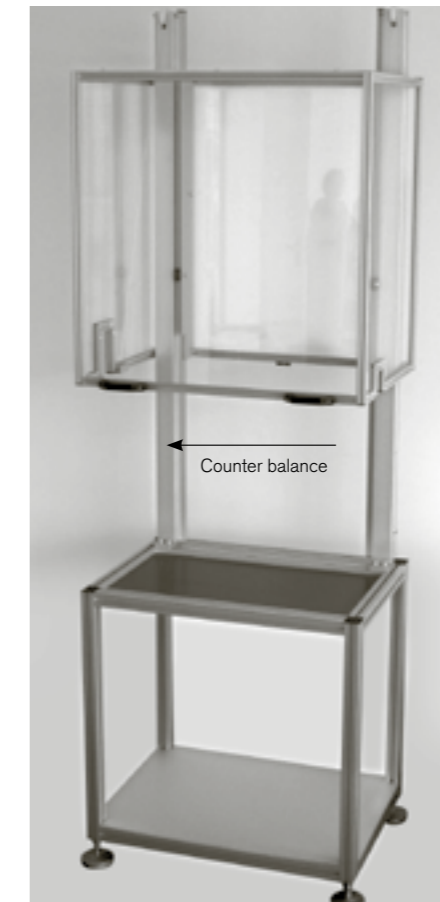
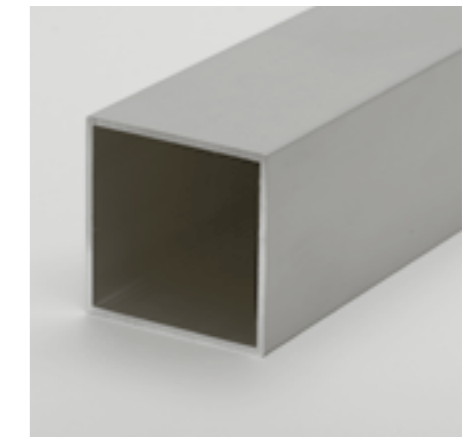
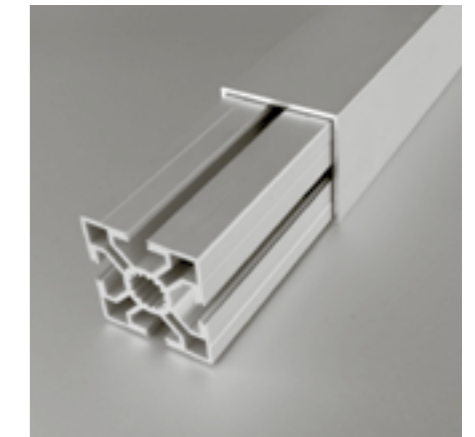

**Order data**      **Order number**

Rectangular tube 55x55 Standard length 6000mm	A19-5-6M
Rectangular tube 55x55 Cut to length	A19-5-02-02/...
Rectangular tube 50x50 Standard length 5000 mm	E19-5-5M
Rectangular tube 50x50 Cut to length	E19-5-02-02/...
Rectangular tube 45x45 Standard length 5000 mm	C19-5-5M
Rectangular tube 45x45 Cut to length	C19-5-02-02/...
Rectangular tube 35x35 Standard length 5000 mm	B19-5-5M
Rectangular tube 35x35 Cut to length	B19-5-02-02/...

## Counterweight extrusion 50x100 type A19-2

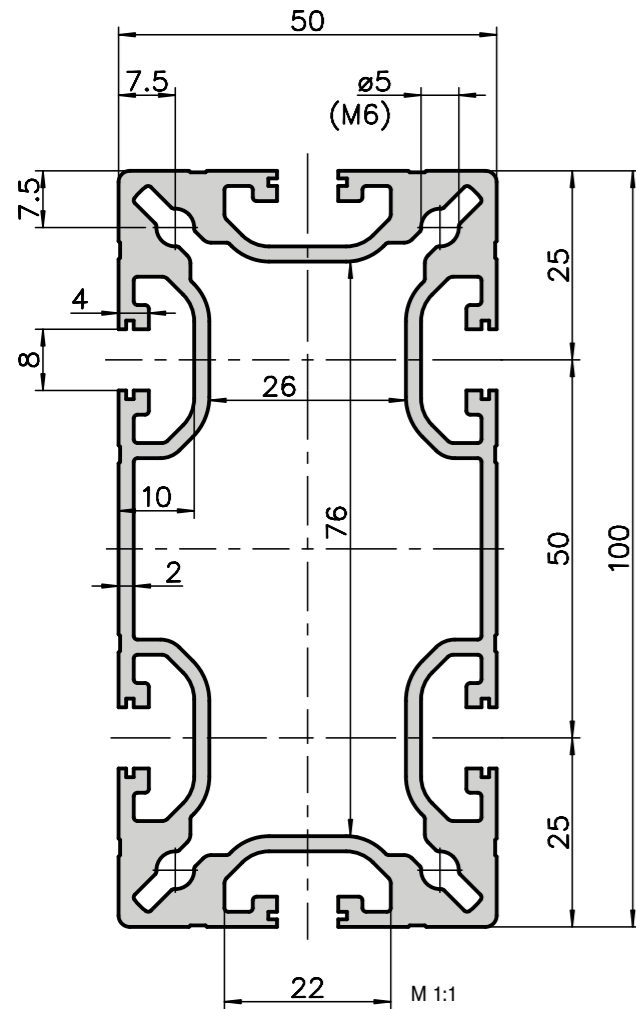

### Application

Counterweights can be inserted into this extrusion for vertical sliding doors. This is a combination extrusion of base 40 + 50. The slots are based on the geometry of base 40 which is why base 40 accessories are the most suitable to use.

This extrusion can be connected to the PVS® Direct ([page 77](#)).

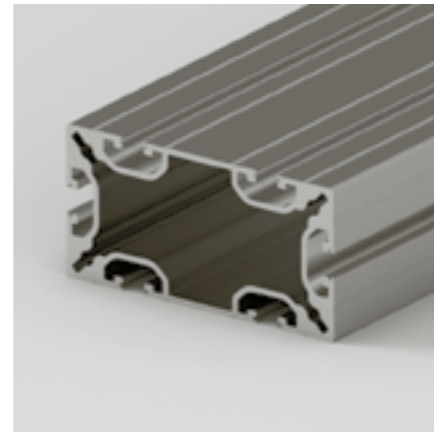

### Technical data

$I_x$	=	41.82 cm <sup>4</sup>
$I_y$	=	16.43 cm <sup>4</sup>
$W_x$	=	8.36 cm <sup>3</sup>
$W_y$	=	6.57 cm <sup>3</sup>
Cross-section area	=	12.33 cm <sup>2</sup>
Weight	=	3.33 kg/m
Alloy		EN AW-6063

### Order data      Order number

Counterweight extrusion 50x100	
Standard length 6000mm	A19-2-6M
Cut to length	A19-2-02-02/...



## Connection technology



Video connection technology

## Kanya connection technology

The extrusion connection system PVS® opens up new possibilities for all structural design problems, whether for machinery, transfer and handling systems, guards, machine enclosures, work benches, laboratory facilities, cabinets, room partitions or exhibition stands. Rectangular, round, square or diagonal, fixed or swivelling: Kanya is the perfect solution.

### Quick, secure connections:

Kanya PVS® makes it possible to erect any structure in a very short time. The system centers around Kanya's own invention, the internationally patented PVS® connector. Any extrusions can be joined together securely.

### Simple and versatile assembly:

The two fundamentals which allow you to build a structure to your own design are ease of assembly and a comprehensive range of extrusions and accessories. Modifications or additions can be easily made, when the need arises, without wasting any material.

### Highly cost-effective:

Any part can be customised. There is no need for expensive finishing or surface treatments. Expensive construction is minimised, saving time and reducing costs. All the parts can be reused repeatedly since all joints are simple to dismantle. That's what makes this system the most cost effective you can buy in the long run.

### An example of making a simple 90° connection.

All the Kanya PVS® connections work on this simple principle, regardless of direction or size.



1. Insert the barrel into the hole made in the second extrusion.



2. Insert the sprung anchor into the centre hole of the barrel.



3. Push the anchor head into the slot of the first extrusion; twist 90°. Tighten the Allen screw. That's all.



## PVS® connectors - overview

### 1. Universal connections

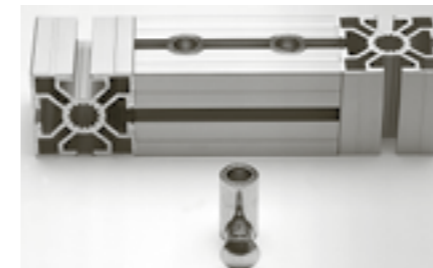

The round anchor head allows the extrusions to be set in any position, however it must first be pushed into the retaining slot. **Also available in stainless steel or providing electrical bonding. (electrically conducting)**



### 2. Standard connections

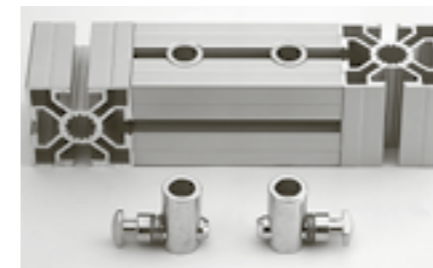

The milled anchor heads allow extrusions to be added subsequently. Horizontally and vertically milled anchor types are required to guarantee that every extrusion position is possible. **Also available in stainless steel or providing electrical bonding. (electrically conducting)**



### 3. Combination connections

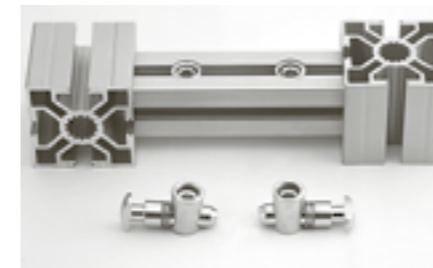

To provide the optimum connection for all cross-sections, the combination connectors are used in a similar way to the standard connection.



### 4. Special connections



The special anchor, which is available in different lengths, makes parallel and cross connections possible.



**5. Mitred connections**



The formed anchor head – 15°, 30° and 45° in both left and right designs – or with an articulated head to create connections at virtually any angle

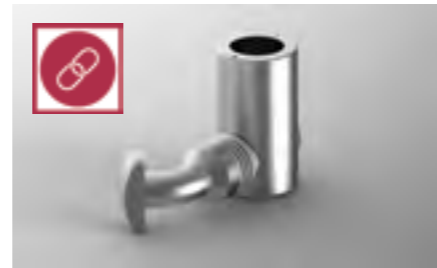

**6. Double mitred connections**



The anchor which can be swivelled from 0° – 90° can be used universally and creates a sturdy frame with slots all around.

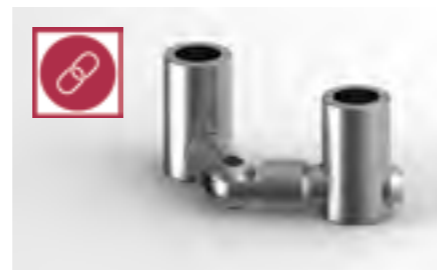

**7. Extrusion extensions**



The rigid anchor guarantees an extremely stable extrusion extension



**8. Threaded connections**



The threaded anchor (M6 / M8) enables the extrusion to be attached to other structures. And the erection of a machine safety guard on an existing work top without any additional fixings.



**1. Universal connector**

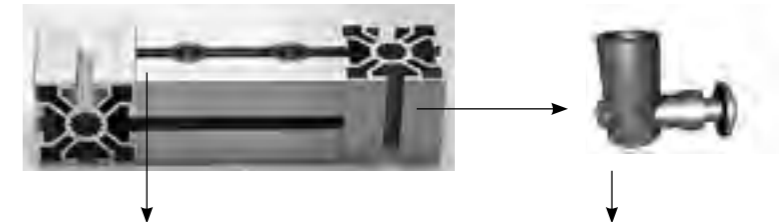

Extrusion with base	Order number				
	50	45	40	30	20
50	A20-90 (-I/-P)*				
45	E20-90 (-I/-P)*	E20-90 (-I/-P)*			
40	C20-90 (-I/-P)*	C20-90 (-I/-P)*	C20-90 (-I/-P)*		
30	B210-90 (-I/-P)*	B210-90 (-I/-P)*	B210-90 (-I/-P)*	B20-90	
Core hole 20 12.1 mm	D210-90 (-I/-P)*	D210-90 (-I/-P)*	D210-90 (-I/-P)*	D20-90	D20-90
Core hole 20 6.0 mm	DD210-90	DD210-90	DD210-90	DD20-90	DD20-90
A02-8	A20-95				
C02-8 / CO3-8	C20-95	C20-95	C20-95		
B01-8	B210-95	B210-95	B210-95	B20-95	

**2a. Standard connector  
Drill across to nut**

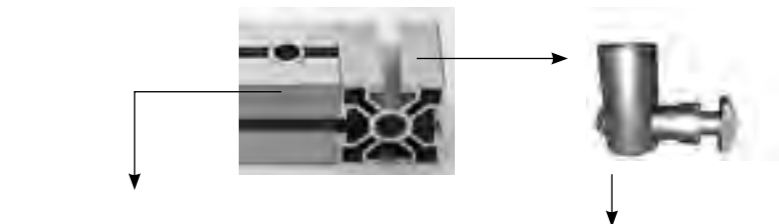

Extrusion with base	Order number				
	50	45	40	30	20
50	A20-10(-I/-P)*				
45		E20-10(-I/-P)*			
40			C20-10(-I/-P)*		
30				B20-10(-I/-P)*	
Core hole 20 12.1 mm					D20-10(-I/-P)*
Core hole 20 6.0 mm					DD20-10
A02-8	A20-50				
C02-8 / CO3-8	C20-50	C20-50	C20-50		
B01-8				B20-50	

**2b. Standard connector  
Drill parallel to nut**

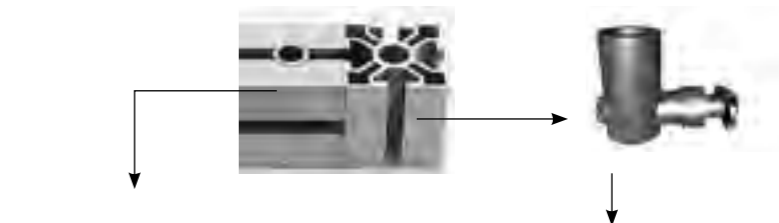



Extrusion with base	Order number				
	50	45	40	30	20
50	A20-20(-I/-P)*				
45		E20-20(-I/-P)*			
40			C20-20(-I/-P)*		
30				B20-20(-I/-P)*	
Core hole 20 12.1 mm					D20-20(-I/-P)*
Core hole 20 6.0 mm					DD20-20
A02-8	A20-51				
C02-8 / CO3-8	C20-51	C20-51	C20-51		
B01-8				B20-51	

\*...-P = connectors with electrical bonding

\*...-I = connectors stainless steel 1.4305



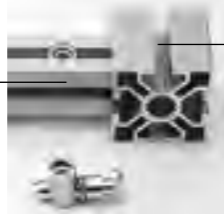

**3a. Combination connector  
Drill across to nut**

Order number

Extrusion with base	50	45	40	30	20
50	A20-10	A20-10	A20-10	AB20-10	AB20-10
45	E20-10	E20-10	E20-10	EB20-10	EB20-10
40	C20-10	C20-10	C20-10	CB20-10	CB20-10
30	B210-10	B210-10	B210-10	B20-10	B20-10
Core hole 20 12.1 mm	D210-10	D210-10	D210-10	D20-10	D20-10
Core hole 20 6.0 mm	DD210-10	DD210-10	DD210-10	DD20-10	DD20-10
<b>C02-8 / C03-8</b>	C20-50	C20-50	C20-50		
<b>B01-8</b>	B210-50	B210-50	B210-50	B20-50	
<b>A02-8</b>	A20-50	A20-50	A20-50		



**3b. Combination connector  
Drill parallel to nut**

Order number

Extrusion with base	50	45	40	30	20
50	A20-20	A20-20	A20-20	AB20-20	AB20-20
45	E20-20	E20-20	E20-20	EB20-20	EB20-20
40	C20-20	C20-20	C20-20	CB20-20	CB20-20
30	B210-20	B210-20	B210-20	B20-20	B20-20
Core hole 20 12.1 mm	D210-20	D210-20	D210-20	D20-20	D20-20
Core hole 20 6.0 mm	DD210-20	DD210-20	DD210-20	DD20-20	DD20-20
<b>C02-8 / C03-8</b>	C20-51	C20-51	C20-51		
<b>B01-8</b>	B210-51	B210-51	B210-51	B20-51	
<b>A02-8</b>	A20-51	A20-51	A20-51		

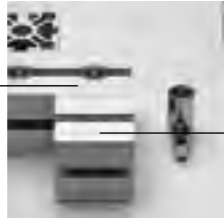

**4a. Special connector,  
from the side outgoing,  
vertical**

Order number

Extrusion with base	50	45	40	30	20
50	A20-10	A20-10	A20-10	AB20-10	AB20-10
45	E20-15	E20-15	E20-15	EB20-15	EB20-15
40	C20-15	C20-15	C20-15	CB20-15	CB20-15
30	B210-15	B210-15	B210-15	B20-15	B20-15
<b>A02-8</b>	A20-50	A20-50	A20-50		

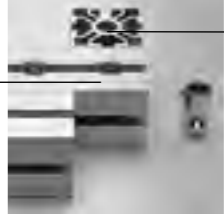

**4b. Special connector,  
from the side outgoing,  
horizontal**

Order number

Extrusion with base	50	45	40	30	20
50	A20-20	A20-20	A20-20	AB20-20	AB20-20
45	E20-25	E20-25	E20-25	EB20-25	EB20-25
40	C20-25	C20-25	C20-25	CB20-25	CB20-25
30	B210-25	B210-25	B210-25	B20-25	B20-25
<b>A02-8</b>	A20-51	A20-51	A20-51		

**5a. Mitred connector with  
formed anchor right**

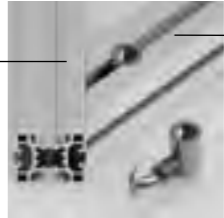

Order number

Extrusion with base	50	45	40	30	20	20*
50	A22- $\alpha$	E22- $\alpha$	C22- $\alpha$	B221- $\alpha$	on request	on request
45		E22- $\alpha$	C22- $\alpha$	B221- $\alpha$	on request	on request
40			C22- $\alpha$	B221- $\alpha$	on request	on request
30				B22- $\alpha$	D22- $\alpha$	DD22- $\alpha$
20					D22- $\alpha$	DD22- $\alpha$

Order code  $\alpha$  15° = -15,  $\alpha$  30° = -30,  $\alpha$  45° = -45

\*with core hole 6.0 mm

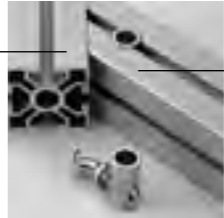
**5b. Mitred connector with  
formed anchor left**

Order number

Extrusion with base	50	45	40	30	20	20*
50	A23- $\alpha$	E23- $\alpha$	C23- $\alpha$	B231- $\alpha$	on request	on request
45		E23- $\alpha$	C23- $\alpha$	B231- $\alpha$	on request	on request
40			C23- $\alpha$	B231- $\alpha$	on request	on request
30				B23- $\alpha$	D23- $\alpha$	DD23- $\alpha$
20					D23- $\alpha$	DD23- $\alpha$

Order code  $\alpha$  15° = -15,  $\alpha$  30° = -30,  $\alpha$  45° = -45

\*with core hole 6.0 mm

**5c. Mitre connector with articulated anchor (up to max 55°)**

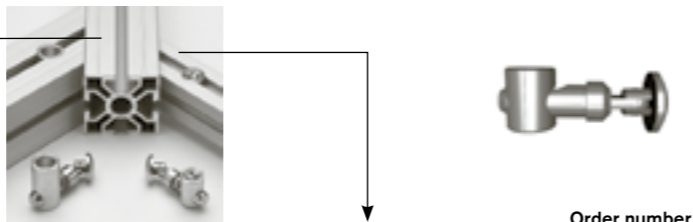

Extrusion with base	50	45	40	30	20	Order number
50	A22-00	E22-00	C22-00	B221-00	D221-00	
45		E22-00	C22-00	B221-00	D221-00	
40			C22-00	B221-00	D221-00	
30				B22-00	D22-00	

**5d. Mitre connector with articulated anchor 90° (up to max 55°)**

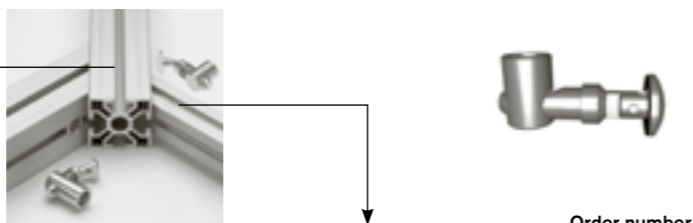

Extrusion with base	50	45	40	30	Order number
50	A22-90	E22-90	C22-90	B221-90	
45		E22-90	C22-90	B221-90	
40			C22-90	B221-90	
30				B22-90	

**6a. Double mitre connector with articulated anchor 90° (up to max 55°)**

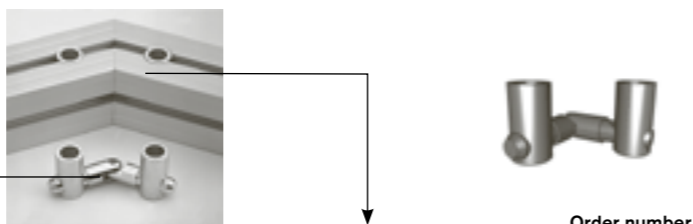

Extrusion with base	50	45	40	30	20	20*	A02-8	C02-8	B01-8	Order number
50	A24-10									
45		E24-10								
40			C24-10							
30				B24-10						
Core hole 20 12.1 mm					D24-10					
Core hole 20 6.0 mm						DD24-10				
A02-8							A24-51			
C02-8 / C03-8								C24-51		
B01-8									B24-51	

\*with core hole 6.0 mm

**6b. Double mitre connectors sideways**

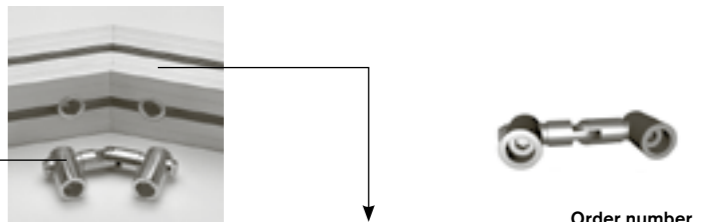

Extrusion with base	50	45	40	30	20	20*	A02-8	C02-8	B01-8	Order number
50	A24-19									
45		E24-19								
40			C24-19							
30				B24-19						
Core hole 20 12.1 mm					D24-19					
Core hole 20 6.0 mm										
A02-8							A24-59			
C02-8 / C03-8								C24-59		
B01-8									B24-59	

\*with core hole 6.0 mm

**7. Extrusion extension connectors**

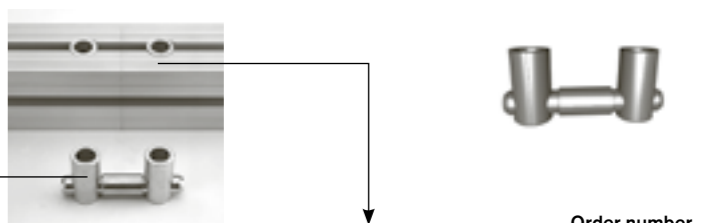

Extrusion with base	50	45	40	30	20	20*	A02-8	C02-8	B01-8	Order number
50	A24-00									
45		E24-00								
40			C24-00							
30				B24-00						
Core hole 20 12.1 mm					D24-00					
Core hole 20 6.0 mm						DD24-00				
A02-8							A24-50			
C02-8 / C03-8								C24-50		
B01-8									B24-50	

\*with core hole 6.0 mm

**8. Threaded connectors**

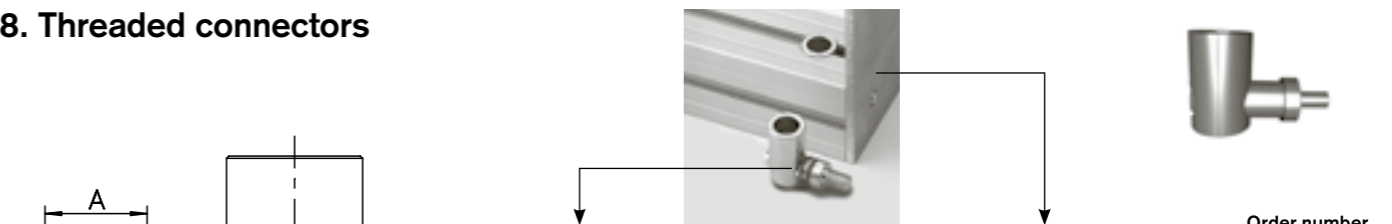

Extrusion with base	Gewinde	M6	M8	A	Order number
50		A20-66	A20-60	13	
45		E20-66	E20-60	13	
40		C20-66	C20-60	13	
30		B20-66	B20-60	10	
Core hole 20 12.1 mm		D20-66	D20-60	10	
Core hole 20 6.0 mm		DD20-66		7	
A02-8		on request	A20-65		
C02-8 / C03-8		on request	C20-65		
B01-8		on request	B20-65		

9a. Tube connector transverse to extrusion axle

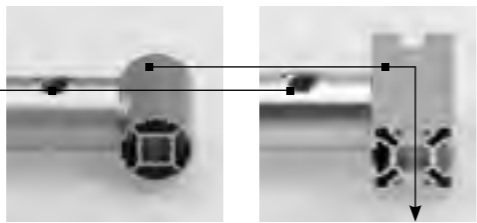

Order number

Extrusion tube Ø	Ø 30	■ 30	■ 40/45/50
30	R30-30-10	R30-35-10	R30-45-10

9b. Tube connector parallel to extrusion axle

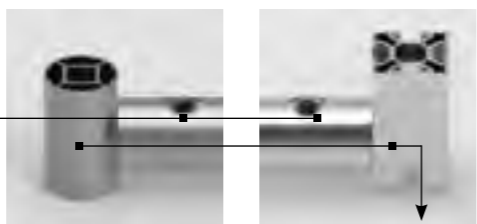

Order number

Extrusion tube Ø	Ø 30	■ 30	■ 40/45/50
30	R30-30-20	R30-35-20	R30-45-20

10. Tube tread connector

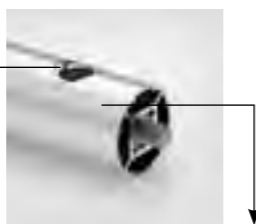

Order number

Extrusion tube Ø	M6	M8
30	R30-30-66	R30-30-60

Covering cap for PVS-connector

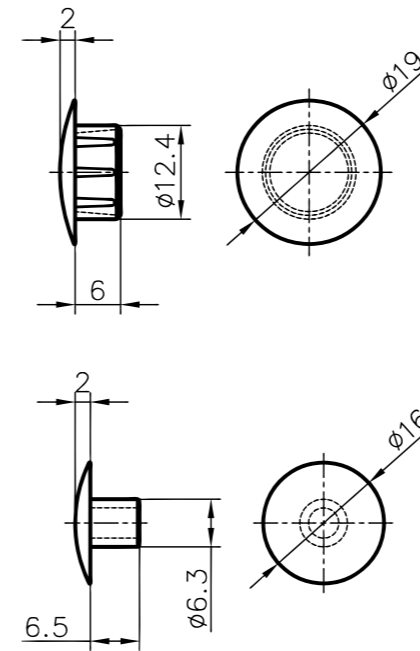

PVS® screw «Safe»



Special PVS® screw Safe M12x12 for safety constructions which must not be easy to dismantle by unauthorised persons. A pin inhibits access to the screw so that it cannot be unscrewed using a commercially available Allen key.

Application

The covering cap for the PVS-connectors have two functions: aesthetics and protection. With the connector on a face side of an extrusion, it covers the visible part of the connector. If the application is in a dirty environment, it is wise to protect the screws from dirt to allow functionality.

Covering cap



Specification

Material PE, gray

Order data	Order number	
Plastic cap	grey	black
Base 50 / 45 / 40	A40-99	A40-98
Base 30	B40-99	B40-98

Order data	Order number
PVS® screw Safe	125-80-S

## Strength specifications

That chart shows the shearing forces in relation to torque and number of connectors of the most important extrusion combinations.

At a torque of 30Nm lies the shearing force for a connection with one connector at approximately 4000N.

Recommended torque: for the universal and standard connectors:

Extrusion base 50/45/40: 30–35Nm

Extrusion base 30/20: 20–25Nm

Extrusion base 20 (Ø6): max. 6Nm  
(other connectors on request)

### Remark:

The tightening torques should not exceed above mentioned recommended specifications:

⇒ The anchor head may be damaged or broken.

Those in the chart stated tractive forces are approximate value. Conditions: Preload of connectors with max. tightening torques!

### Thrust forces

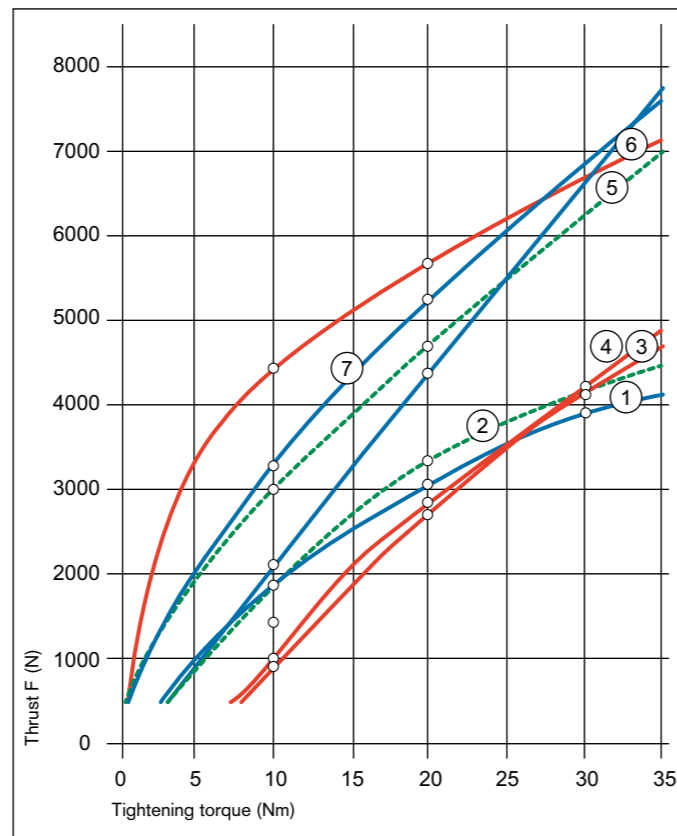

No.	extrusion	joints
1	50x50	1
2	40x40	1
3	30x30	1
4	30x50	1
5	40x80	2
6	30x100	2
7	50x100	2

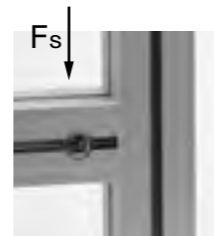

### Tractive forces (strong slot version)

Tractive force extrusion	Fz Universal connectors	Fz Standard connectors
Base 50	14'000N	10'000N
Base 45	14'000N	10'000N
Base 40	14'000N	10'000N
Base 30	4'000N	3'500N
Base 20	2'000N	1'800N

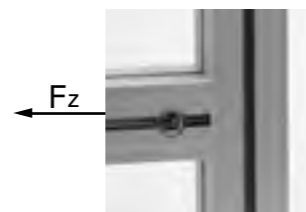

### Tightening torques and tensile forces for threaded plates and sliding blocks



#### Tightening torques for threaded plates

	M5	M6	M8
Base 40/45/50	6Nm	10Nm	15Nm
Base 20/30	4Nm	6Nm	6Nm

#### Pull-out force threaded plates

Base 50 / 45 / 40	10'000N
Base 30	3'500N
Base 20	1'800N

#### Pull-out force nuts\*

Base 50 / 45 / 40	8'000N
Base 30	3'000N
Base 20	1'500N

\*Swivel in nut with strong nut

The tear-out force depends basically on the nut geometry, as the weakest point is the aluminium nut. Pay attention to the nut thickness.

strong version

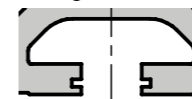

light version

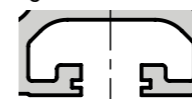

### Frontal pull-out forces from the central thread length 25mm

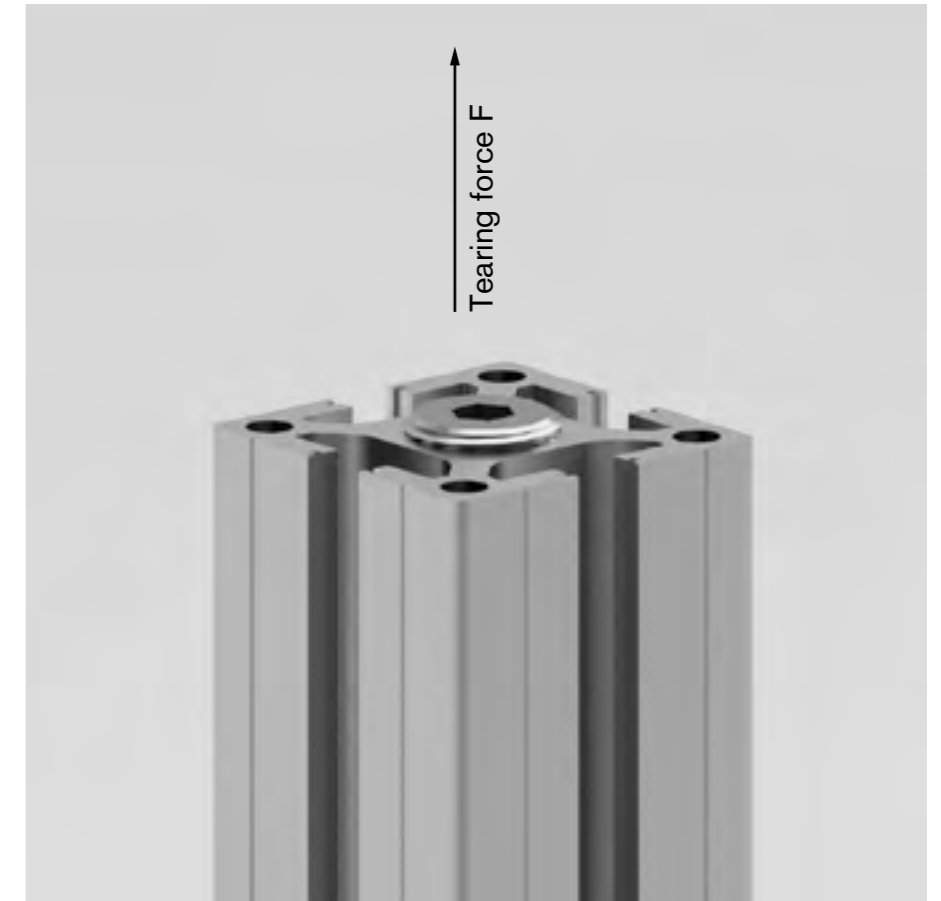

#### Centre hole Extrusion base 40/45/50

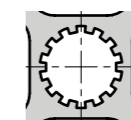

F in N  
65'000

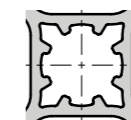

42'000

#### Centre hole Extrusion base 30

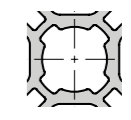

F in N  
48'000

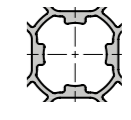

22'000

The tightening torques for the self-cutting thread inserts are 8Nm for all extrusion sizes.

## PVS® direct connectors

### Base 50

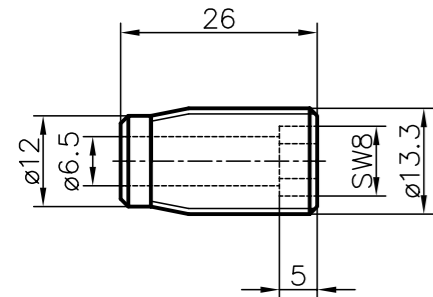

### Base 45

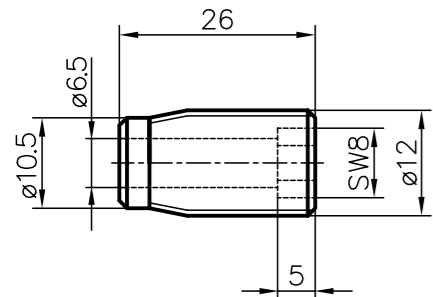

### Base 40

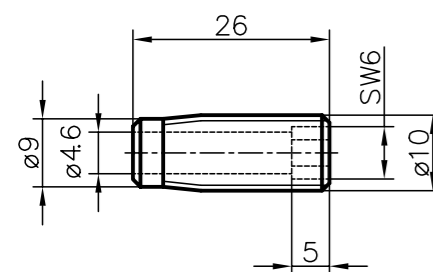

### Base 30

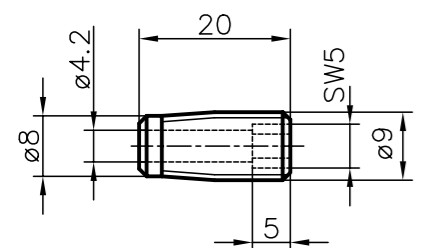

Connectors of different profile sizes on request

### Application

The extrusion does not need to be machined for this connection. This selfcutting threaded sleeve has a shank for an Allen key which is simply used to screw it into the longitudinal slot. The screw is mounted into the threaded sleeve in advance, thereby connecting the extrusion to the extrusion nuts in the counter extrusion. These can be installed afterwards. This stable connection, assembly is slightly more complex than with the PVS® standard connector. The prerequisite for this connection is access on both sides to the slots.

### Note

The side slots are blocked by the connection. Panels would therefore have to be machined the site of the fasteners. The partial thread flanks reduce the strength of the force transmission. The strength is therefore slightly lower than that of the standard PVS® connector. The

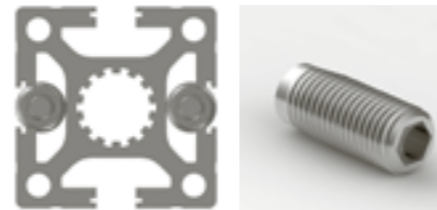

Selfcutting threaded sleeve

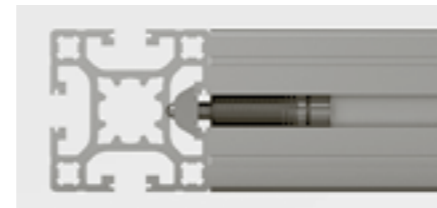

Built-in connector

nut can bend open under moment loads. In addition, the nut depth of base 30 is too shallow to fully insert the connector into the nut; the thread insert protrudes slightly from the nut.

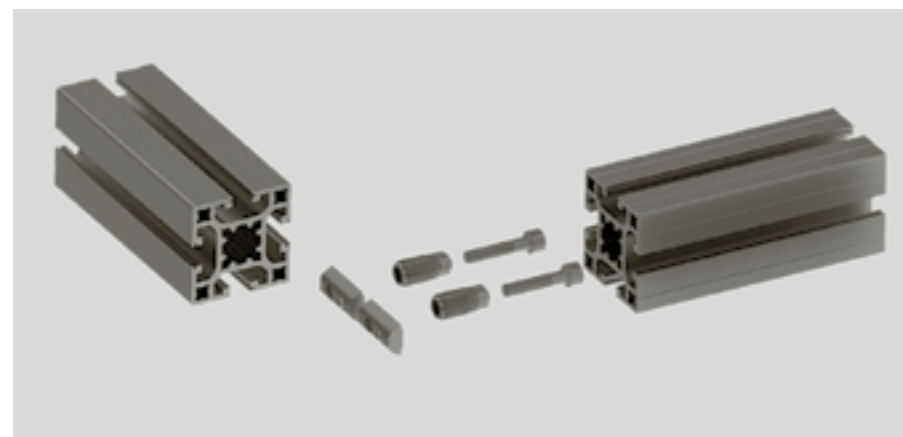

### Parts supplied

- 2 screws
- 2 threaded sleeves
- 1 double extrusion nuts (Base 30: 2 swivel in nuts)

Order data	Order number
Base 50	A33-90
Base 45	E33-90
Base 40	C33-90
Base 30	B33-90

## The Kanya connection technology

### PVS®-SUPERLIGHT

1. Insert the self-cutting threaded insert into the extrusion centre hole.

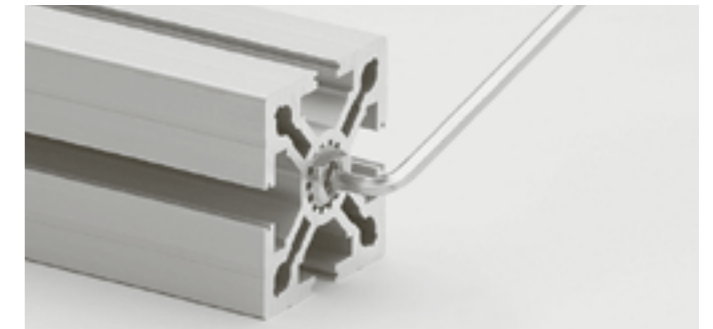

2. Drill a stepped hole into the extrusion.

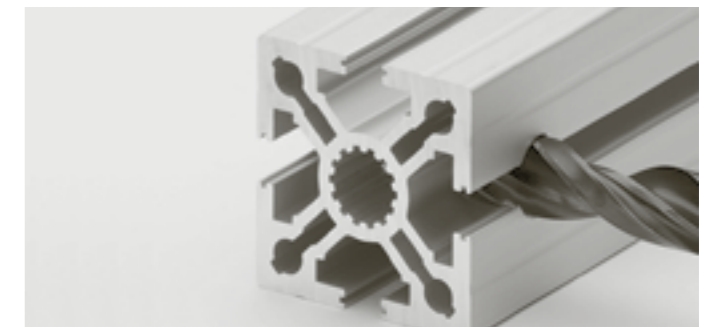

3. Tighten the socket-head cap screw – finished!



### Note:

Instead of a stepped hole, you can also just drill a simple hole for the allen key and then insert a round-head screw into the counter slot.

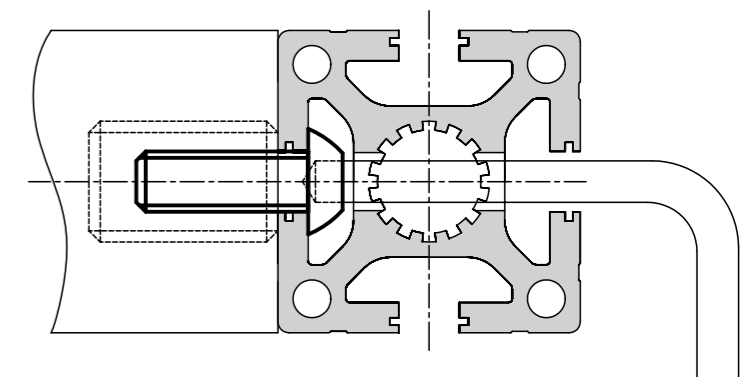

## Cable bridge for electrical conductivity

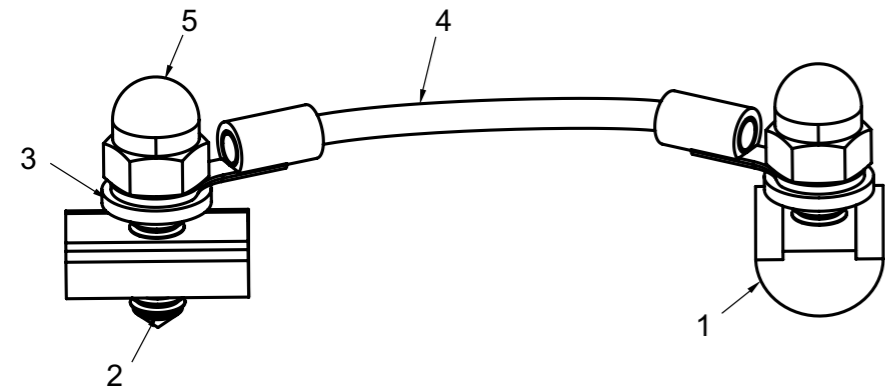

### Application

If extrusions have to be electrically connected with other components, e.g. ESD, these connections can be realized with simple components.

We recommend the connectors with potential equalization (-P) for Kanya extrusions.

### Parts supplied

- 1 Swiveled extrusion nut (2)
- 2 grub screws with point (2x)
- 3 washers (2x)
- 4 cables with cable lug (1mm<sup>2</sup>) approx. 100mm (1x)
- 5 swiveling cap nuts (2x)



Order data	Order number
Cable bridge	
Base 30	B36-00
Base 40	C36-00
Base 45/50	AE36-00

## Allen key set SW 1.5 – 10

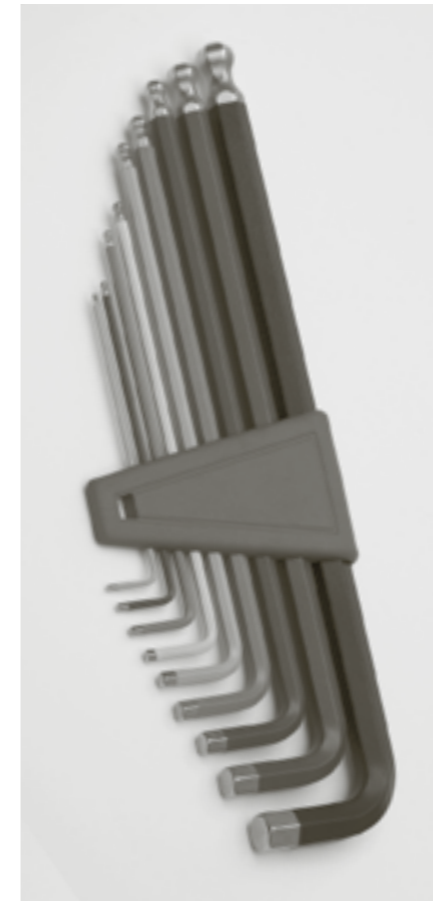

### Application

For all screw-in parts with hex key.

The ball-shaped ends allows it to screw into angular positions with the allen key. This is necessary for the function of the new patent PVS®-EASY connector.

Order data	Order number
Allen key set SW 1.5 – 10	E97-5

SW = wrench size

## Kanya Allen key SW 6



### Specification

Zinc-coated steel

Order data	Order number
KANYA Allen key SW 6 short	E97-1
KANYA Allen key SW 6 long	E97-2

## Allen key for PVS® screw Safe



### Application

Special Allen key for the PVS® connectors with PVS® screw Safe M12x12.

Order data	Order number
KANYA Allen key for PVS® screw Safe	E97-2-S 125-80-S



**Accessories**

## Mounting brackets

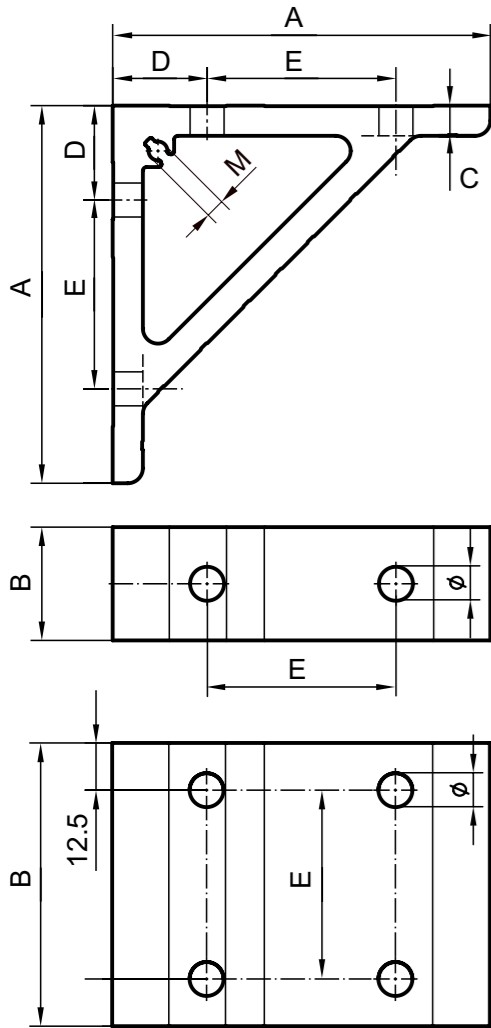

**Application**

Mounting brackets are simple joining parts which can also be used in combination with PVS®. They are used primarily for reinforcement.

**Specification**

Aluminium, matt, anodised in natural colours

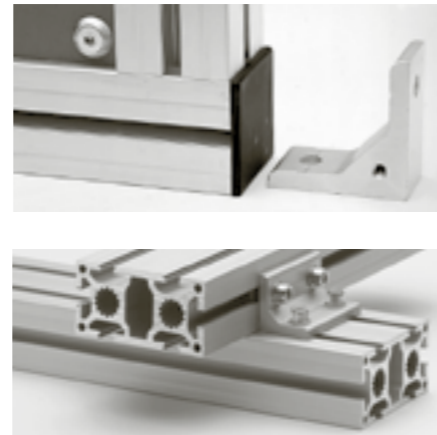
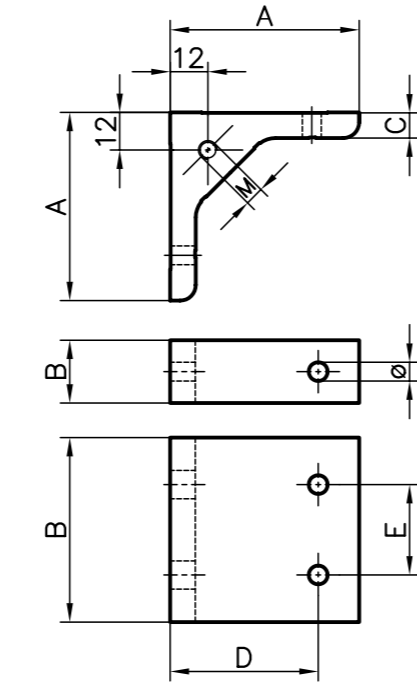
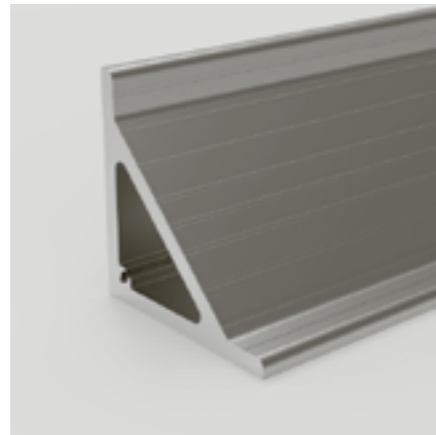

**Measurement data**    **Order number**

A	B	C	D	E	Ø	M*	
100	30	8	25	50	9	-	A30-41
100	75	8	25	50	9	-	A30-42
100	30	8	35	55	9	-	A30-43
100	30	8	35	55	9	M6	A30-44
100	20	8	35	55	6.5	-	B30-43
100	20	8	35	55	6.5	M6	B30-44
70	25	5	20	40	6.5	-	C30-30
70	65	5	20	40	6.5	-	C30-32

\*insert



**Measurement data**    **Order number**

A	B	C	D	E	Ø	M*	
60	20	8	45	-	6.5	-	B30-12
60	20	8	45	-	6.5	M6	B30-22
60	30	8	45	-	9	-	A30-12
60	30	8	45	-	9	M6	A30-22
38	70	8	22.5	45	9	-	E30-02
38	30	8	22.5-25	-	9	-	AE30-00
38	80	8	25	50	9	-	A30-02
31	20	6	20	-	6.5	-	C30-00
31	60	6	20	40	6.5	-	C30-02

\*Thread

## Mounting brackets

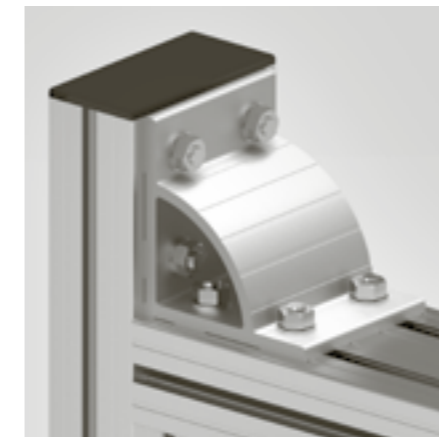
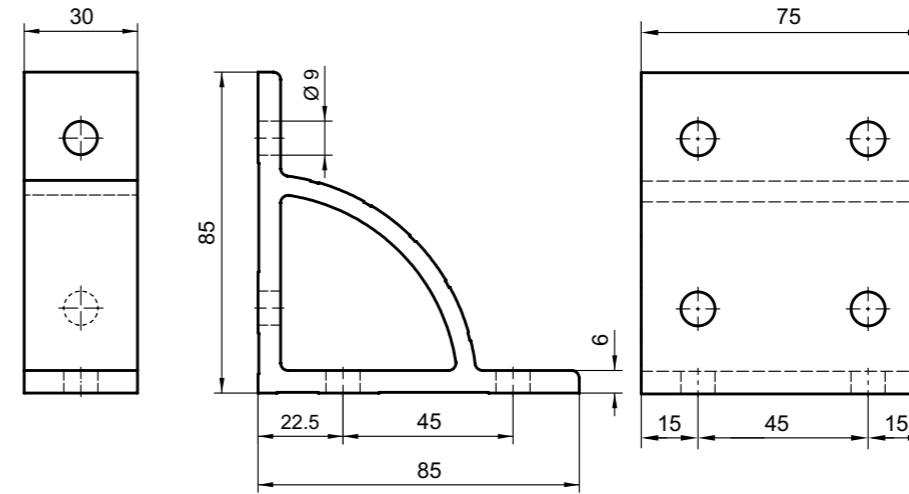

**Application**

The bracket is aligned in the centre distances for base 45. The elegant support arch permits good access for tightening the bolts.

**Specification**

Aluminium, matt, anodises in natural colours

**Order data**    **Order number**

Mounting bracket 85x85x30	E30-30
Mounting bracket 85x85x75	E30-32

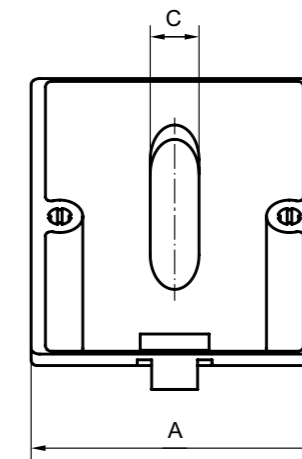

Base	A	B	C
50	50	25	8.5
40	40	20	7

## Brackets

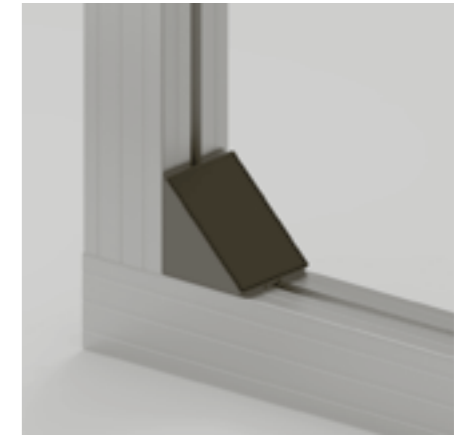

**Application**

Due to its size, the small bracket can be mounted lengthwise, but also crosswise to the extrusion. The matching cover cap conceals the screws and also meets design requirements.

**Specification**

Die-cast zinc, grey powder-coated RAL 7035

**Scope of delivery**

- 1 zinc die-cast angle
- 1 black plastic cover cap

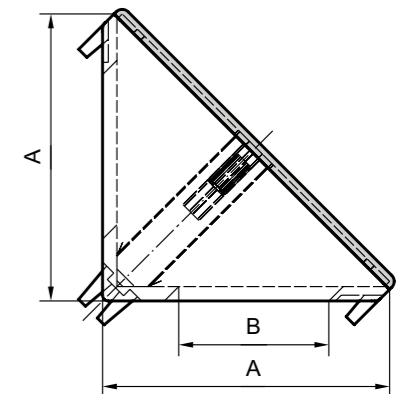

**Order data**    **Order number**

Bracket, Base 50	A25-10
Bracket, Base 40	C25-10





### Attachment bracket

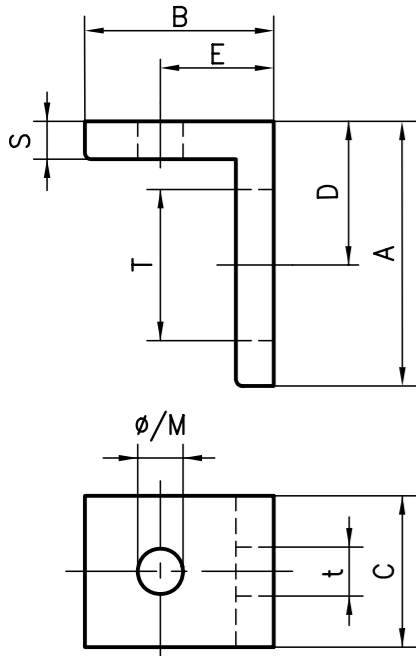

**Application**

The fixing angle is used to mount additional equipment, panelling, work tops, valves, electrical switchgear, etc. The advantage of these is that they are slotted on one side, allowing fine adjustment.

**Specification**

Aluminium, matt, anodised in natural colours

### T-bolts

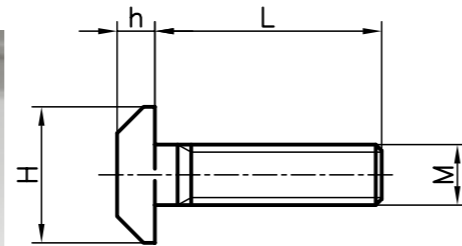

**Application**

T-bolts are used to fasten all types of components and are simple to insert, even after assembly. The anti-twist shape is a help during assembly.

**Specification**

8.8 steel, zinc-coated

**Scope of delivery**

Screw, hexagonal nut, washer



### Threaded plates

**Extrusion base of 50 / 45 / 40**

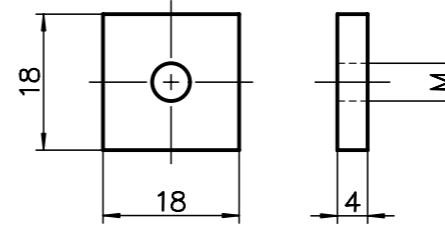

**Extrusions base of 30 and 20**

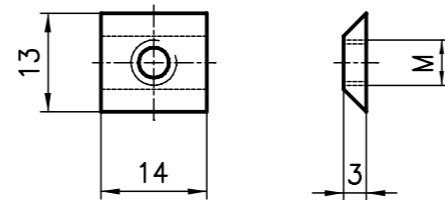

**Application**

For attaching components which are anything up to medium weight. Threaded plates must be inserted into the front-end of the extrusion slots.

**Specification**

Threaded plates: Zinc-coated / stainless steel  
Base 50/45/40 supporting cage: PP  
Base 30 spring steel retaining spring

### Double threaded plates

**Extrusions base of 50 / 45 / 40**

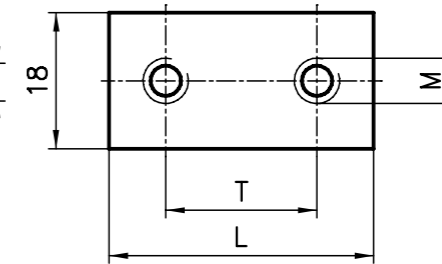

**Extrusions base of 30 and 20**

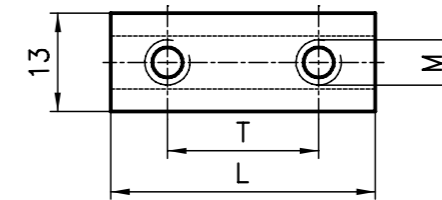

**Measurement data**

Extrusion base	L	T	M
50/45/40	45	30	M6
	30	18	M5
30/20	45	30	M6
	28	18	M5

**Application**

The M6 double extrusion nuts are used for attaching hinges, M5 is used for arrester plate.

### Halfround threaded plates Base 50

**Extrusions base of 50**

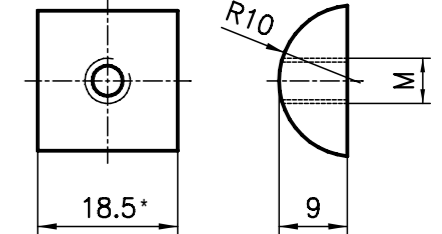

**Application**

Halfround threaded plates can only be used with 50 mm base extrusions. These plates are only available threaded M10.

**Specification**

zinc-coated steel

Order data									Order number	
A	B	C	D	E	S	Txt	Ø	Thread	Through-hole Ø	Thread
45	45	20	25	25	5	20x6.5	6.2	M6	A30-76	A30-86
35	25	20	19	15	5	20x6.5	4.2	M4	A30-54	A30-64
35	25	20	19	15	5	20x6.5	5.2	M5	A30-55	A30-65
35	25	20	19	15	5	20x6.5	6.2	M6	A30-56	A30-66
25	25	15	14	15	4	13.5x6	3.2	M3	B30-53	B30-63
25	25	15	14	15	4	13.5x6	4.2	M4	B30-54	B30-64
25	25	15	14	15	4	13.5x6	5.2	M5	B30-55	B30-65
25	25	15	14	15	4	13.5x6	6.2	M6	B30-56	B30-66

Order data			Order number
MxL	H	h	
<b>Extrusion base 50 / 45 / 40</b>			
M8x20	18	5	A35-20
M8x25	18	5	A35-25
M8x30	18	5	A35-30
M8x40	18	5	A35-40
M8x60	18	5	A35-60
<b>Extrusion base 50 / 45 / 40</b>			
M6x18	18	5	C35-18
M6x25	18	5	C35-25
M6x30	18	5	C35-30
<b>Extrusion base 30</b>			
M6x15	13	4	B35-15
M6x20	13	4	B35-20
M6x30	13	4	B35-30
M6x40	13	4	B35-40



Order data	Order number	
Thread M	Extrusions base	
	50 / 45 / 40	30 / 20
M3	-	B32-30 (-I)
M4	AC32-40 (-I)	B32-40 (-I)
M5	AC32-50 (-I)	B32-50 (-I)
M6	AC32-60 (-I)	B32-60 (-I)
M8	AC32-80 (-I)	B32-80 (-I)*

(-I=Inox) \* No full torque possible.



Order data	Order number	
Double extrusion nuts	Extrusions base	
Thread M	50 / 45 / 40	30 / 20
M5	A32-58	B32-58
M6	A32-68	B32-68



Order data	Order number
Halfround threaded plates	Extrusions base 50
Thread M	
M6	A32-61
M8 *	A32-81
M10	A32-91

\* 25 mm

Further dimensions on request

### Extrusion nuts Clamping nuts

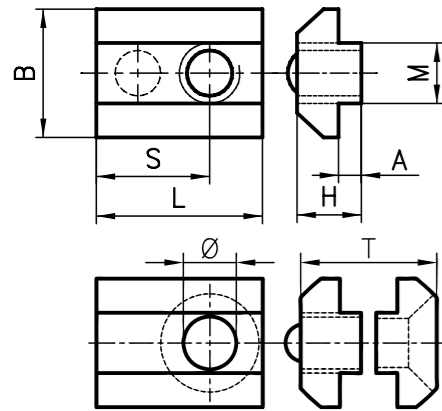

**Measurement data**

Extrusion base	B	H	L	S	A	T	Ø
50	18	12.2	25	15	2.8	-	-
45	20	9	20	14	1	-	-
40	17	8	22	15	2.8	-	-
50/50	18	12.2	25	15	2.8	23	6.5
50/40	18	12.2	25	15	2.8	23	6.5
40/40	17	8	25	15	2.8	19	6.5

**Application**

The extrusion nut is recommended for securing heavy components with high tightening torques. Threaded plates and extrusion nuts are inserted before assembly into the end of the extrusion slots.

**Specification**

zinc-coated steel

Order data	Order number		
<b>Extrusion nuts</b>	<b>Extrusion base</b>		
Thread M	50	45	40
M6	A32-63		C32-63
M8	A32-83	E32-83	C32-83
M10	-	E32-93	C32-93
<b>Clamping nuts</b>	<b>50/50</b>	<b>50/40</b>	<b>40/40</b>
M6	A32-69	A32-69	C32-69

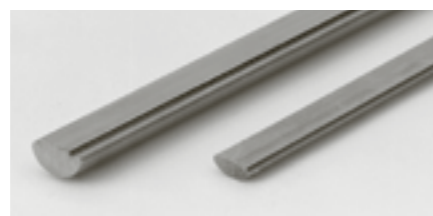
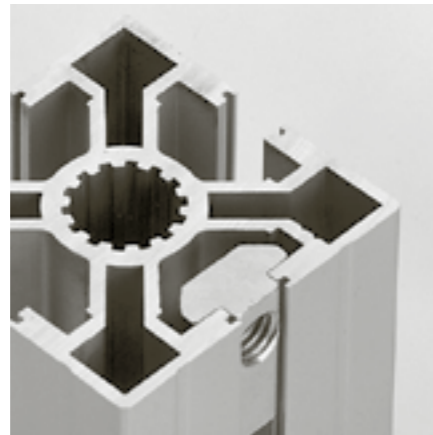

\* no full torque possible (l=Inox)

### Swivel in nut

**Extrusion base 50/45/30**

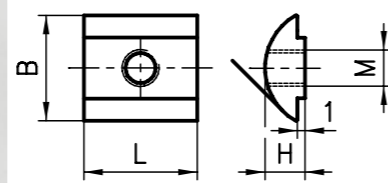

**Extrusion base 40**

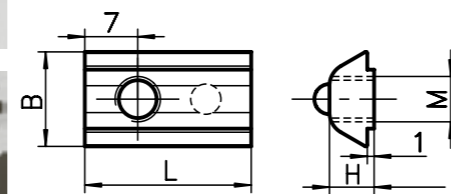

**Measurement data**

Extrusion base	B	H	L
50/45	14	7.8	20
40	12.5	5.9	22
30	11	4.1	20

**Application**

The advantage of the swivel in nut is that they can also be inserted diagonally into the extrusion slots. The disadvantage is that the tightening torques >12 Nm may result in dents in the aluminium extrusion. Raw steel bars are available if you wish to machine special nuts.

If these nuts are tightened to a torque > 10Nm, they meet the ESD guidelines for use with lightweight extrusions.

Order data	Order number		
<b>Swivel in nut</b>	<b>Extrusion base</b>		
Thread M	50/45	40	30
M4	A32-45	C32-45	B32-45 (-l)
M5	A32-55 (-l)	C32-55 (-l)	B32-55 (-l)
M6	A32-65 (-l)	C32-65 (-l)	B32-65 (-l)
M8	A32-85 (-l)	C32-85 (-l)	B32-85* (-l)

<b>Extrusion (raw)</b>			
<b>Swivel in nut</b>			
1.5 m	A32-52	C32-52	B32-52
<b>Heavy nuts</b>			
1.5 m	A32-12	C32-12	

### Double extrusion nuts

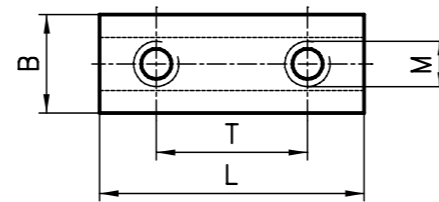

**Measurement data**

<b>Double extrusion nuts</b>						
Extrusion base	B	H	L	T	M	
50 (ball)	18	12.2	80	50	M8	
40 (ball)	17	8	60	40	M8	
50/45	14	7.8	48	33	M6	
40 (ball)	13.6	5.9	38	28.7	M6	

**Swivel in double extrusion nuts**

Extrusion base	B	H	L	T	M
50/45	14	7.8	40	30	M6
40 (ball)	13.6	5.9	40	30	M6
30	11	4.1	40	30	M6
30	11	4.1	30	18	M4

**Application**

Double extrusion nuts should be used with PVS® threaded connectors where extremely high strength joints are required. Swivel in double extrusion nuts are used for the assembly of hinges (page 195) and quick-release fasteners (page 204).



Order data	Order number		
<b>Double extrusion nuts</b>	<b>Extrusion base</b>		
Thread M	50	40	30
M8	A32-84	C32-84	-
<b>Swivel in double extrusion nuts</b>			
M6	A32-67*	C32-67	B32-67
M6	A32-36*	-	-
M5	-	C32-36	-
M4	-	-	B32-47

\* for base 50+45

### Hammer nuts

**Base 50/45/40**

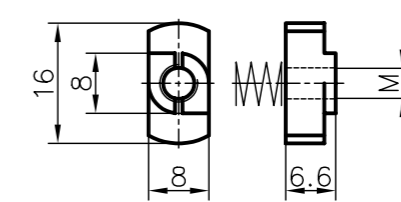

**Base 30/20**

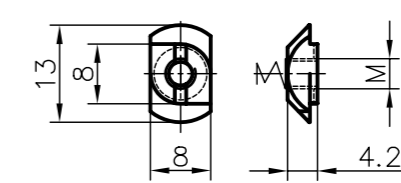

**Application**

The hammer nut can be subsequently inserted into the profile slot. The nuts can be spaced close together because they are only 8 mm wide. However, their load-bearing capability is clearly lower than those of threaded plates and extrusion nuts.

**Specification**

Zinc-coated steel; retaining springs: spring steel



Order data	Order number	
<b>Thread M</b>	<b>Extrusion base</b>	
M3	50/45/40	30/20
M4	AC31-35	BD31-35
M5	AC31-45	BD31-45
M6	AC31-55	BD31-55
M6	AC31-65	BD31-65

### Magnet nuts

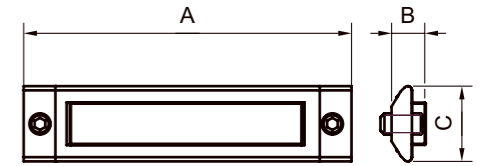

**Measurement data**

Extrusion base	A	B	C
50	58	11.5	15
40	58	8	15
30	62	6.3	14.2

**Application**

The magnetnuts can be inserted into the extrusions of the base 50 and 40 on the open cross section. They can be fixed on position with 2 small screws. With the magnet-nuts you can do a flat door fixing, fixing of metal housing or use it for holding tools.

**Specification**

Surround: plastic  
Screws: zinc-plated  
Magnet: zinc-plated  
Operating temperature: up to 80 °C  
Adhesive strength 150 N

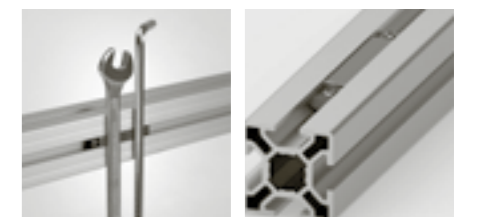

Order data	Order number
<b>Magnet nuts</b>	
Extrusion base 50	A32-86
Extrusion base 40	C32-86
Extrusion base 30	B32-86

## End caps

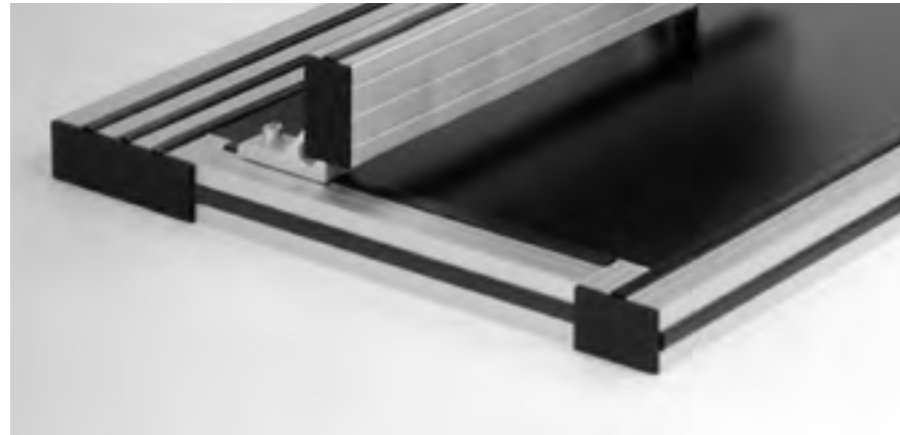
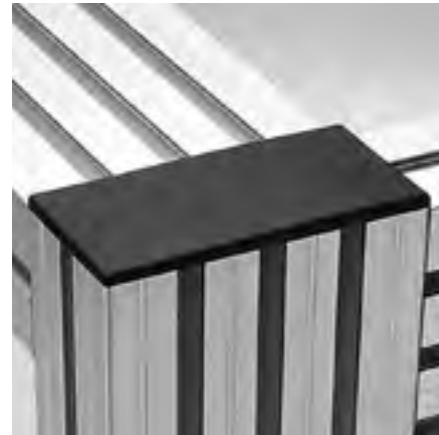

### Application

End caps are used as covers for the exposed ends of extrusions. They prevent injury from the sharp edges of the extrusions. Special centring elements make them easy to fix and prevent the caps from twisting. Two end caps can be used together to cap off larger extrusions, eg extrusion 80x120 uses two 40x120 end caps.

### Specification

PA-GF, black / -G grey

Extrusion	Cap height
Base of 50 / 45 / 40	4 mm
Base of 30 / 20	3 mm



Order data	Order number
------------	--------------

End caps	50x50	A40-10 (-G)
End caps	50x50	A40-19 (Profil A19-1)
End caps	50x45°	A40-80
End caps	50x100	A40-20 (-G)
End caps	50x150	A40-30
End caps	55x55	A40-55 (Profil A19-5)
End caps	100x100	A40-50 (-G)
End caps	45x45	E40-10
End caps	45x90	E40-30
End caps	90x90	E40-50
End caps	45x45	E40-83 (Profil E03-1)
End caps	40x40	C40-10 (-G)
End caps	40x40	C40-83 (Profil C03-8)
End caps	40x45°	C40-80 (Profil C02-8)
End caps	40x45°	C40-84 (Profil C04-4)
End caps	40x80	C40-30 (-G)
End caps	40x120	C40-90
End caps	40x120-G	C40-12 (Profil C08-4)
End caps	80x80	C40-40 (-G)
End caps	16x40	C40-81 (Profil C08-1)
End caps	20x80	C40-82 (Profil C08-2)
End caps	45x45	C40-45 (Profil C19-5)

Order data	Order number
------------	--------------

End caps	30x30	B40-30 (-G)
End caps	30x30	B40-80 (Profil B01-8)
End caps	30x30°	B40-33
End caps	30x45°	B40-45
End caps	30x60°	B40-66
End caps	30x50	B40-90 (-G)
End caps	30x60	B40-60 (-G)
End caps	30x95	B40-50
End caps	30x100	B40-20
End caps	30 8-Kt.	B40-15
End caps	60x60	B40-65
End caps	20x20	D40-30 (-G)
End caps	20x20	D40-80 (Profil D03-8)
End caps	20x40	D40-60
End caps	20x50	D40-50
End caps	ø30	R40-30

## Threaded inserts

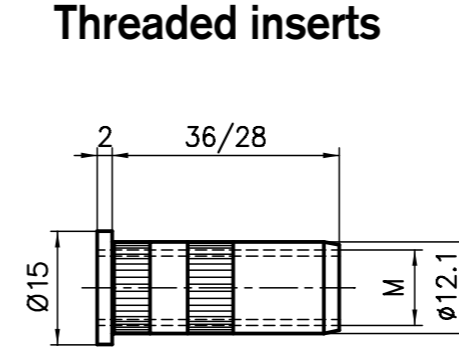

### Application

The threaded insert, which is manufactured with an external knurl, is inserted into a 12 mm hole across the line of the extrusion, enabling levelling feet and casters to be fixed to horizontal extrusions.

### Specification

Zinc-coated steel

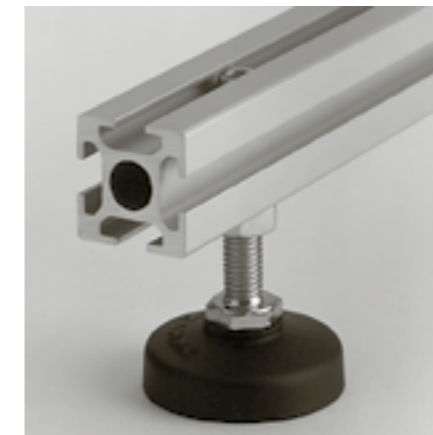

Order data	Order number
------------	--------------

Thread M	Extrusion base	
	50/45/40 (L=36)	30 (L=28)
M10	C33-20	B33-20
M8	C33-22	B33-22

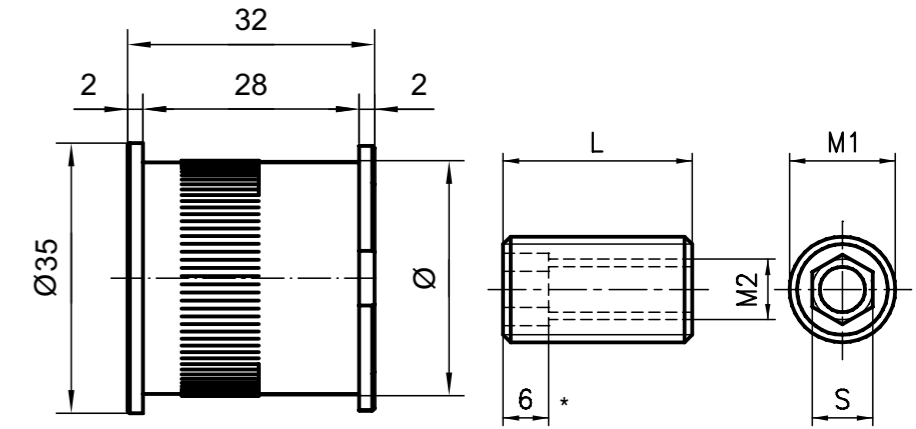

### Application

Once the threaded insert has been pressed into the front side of extrusions B02-6/C03-4/, levelling feet or casters can be attached.

### Specification

Raw aluminium

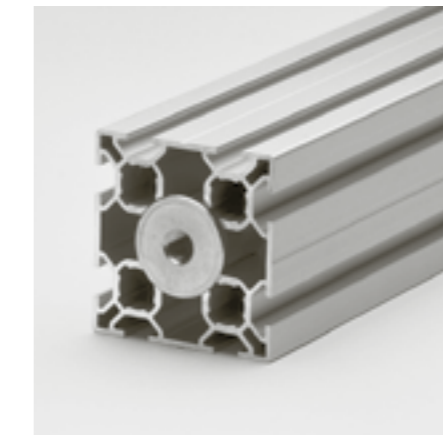

Order data	Order number
------------	--------------

Thread	M	D	L	Extrusion base	
				B02-6	C03-4
M10	ø 24.6	30	B33-60	-	
M14	ø 24.6	30	B33-64	-	
M16	ø 30	30	-	C33-16	

### Application

The screw-in threaded insert is primarily used to take levelling feet and casters or to fix end panels or base plates in place.

Note that there is no thread around \* the hexagon socket.

### Specification

Zinc-coated steel



Order data	Order number
------------	--------------

Thread	M1	M2	S	L	Extrusion base	
					50/45/40	30
M16	M12	12	25	A33-12		
M16	M10	10	25	A33-20 (-I)		
M16	M8	8	25	A33-28 (-I)		
M16	M6	6	25	A33-26		
M14	M10	10	25		B33-21 (-I)	
M14	M8	8	25		B33-28	
M14	M6	6	25		B33-26	

(-I=Inox)

### Self-cutting threaded insert

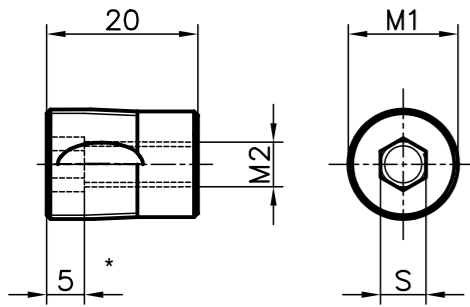

**Application**  
The self-cutting threaded insert has the advantage that no machining is required in order to attach elements on the face. Connections subject to tensile stress are primarily only ideal. This means that attaching levelling feet or casters is not recommended.

Note that there is no thread around \* the hexagon socket.

**Specification**  
Zinc-coated steel

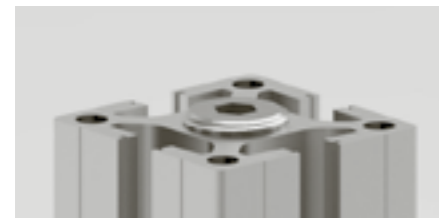

Order data	Order number
------------	--------------

Self-cutting *			Extrusion base	
Thread	M1	M2	S	
	M1	M2	S	50/45/40 30
	M14.5	M6	6	A33-06
	M14.5	M8	8	A33-08
	M14.5	M10	8	A33-10
	M13	M5	6	B33-05
	M13	M6	6	B33-06
	M13	M8	8	B33-08

\* Not suitable for casters/levelling feet

### Expanding sleeve

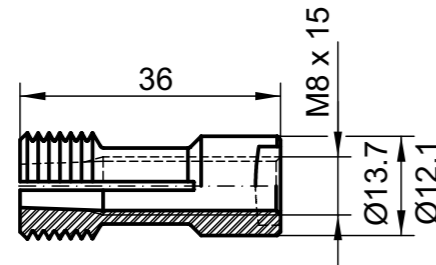

**Application**  
The expanding sleeve is used to create a thread in the centre hole of the cross section. Hammering it in and clamping it with the expansion screw in the cross-section results an M8x15mm.

**Tightening torques**  
Expanding screw:  
min. 10Nm, max. 12Nm

**Specification**  
Zinc-coated steel

**Parts supplied**  
Expanding sleeve, expanding screw



Order data	Order number
------------	--------------

Extrusion base 40, 45, 50 (core drilling Ø13.7)	A20-00
Extrusion base 20 and 30 (core drilling Ø12.1)	B20-00

### Anti-twist spigots

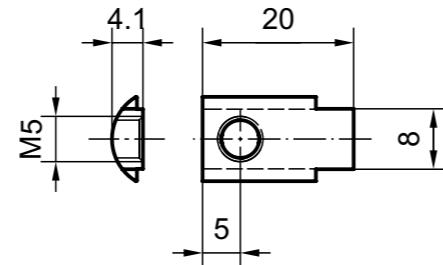

**Application**  
For all extrusions which are assembled with a PVS® connector and which must not twist. The spigot can also be fitted to existing extrusions (does not apply to 20x20 extrusions).

**Specification**  
Zinc-coated steel

**Parts supplied**  
Spigot, adjusting screw

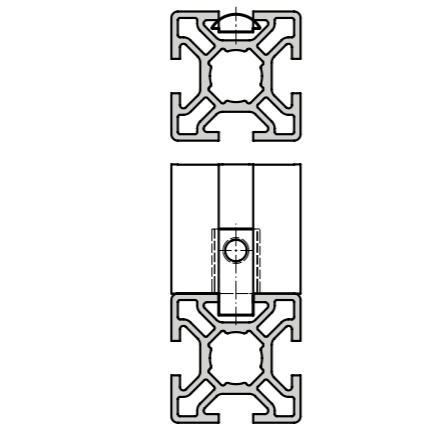

Order data	Order number
------------	--------------

	50/45/40	30/20
Anti-twist spigots	AC29-01	BD29-01

### Levelling feet

#### Levelling feet

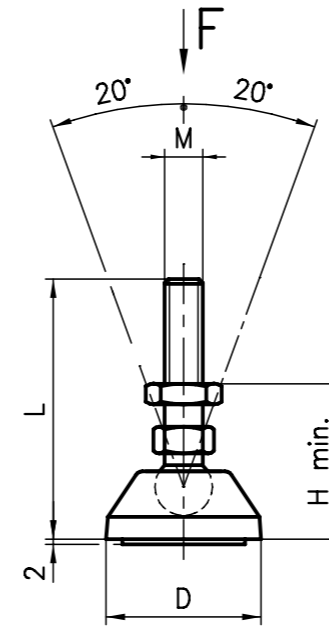

**Specification**  
Cup: glass-filled Polyamide (PA-GF) black  
Bolt/locknut: 8.8 steel, zinc-coated  
Anti-slide pad: NBR rubber



Order data	Order number
------------	--------------

MxL	D	H	F	Order number
M6x57	19	20	500 N	B43-02
M10x75	29	35	2000 N	B43-10
M10x75	39	35	3000 N	B43-11
M10x75	49	37	3000 N	B43-12
M16x155	39	38	8000 N	B43-16

Other dimensions or special feet are available on demand.

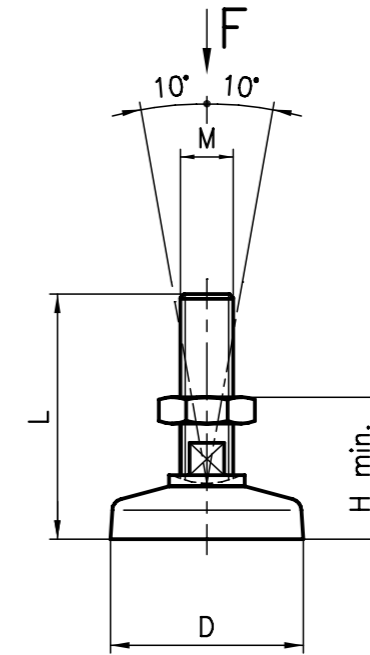

**Application**  
These continuously variable levelling feet are used for many different applications. The cup is attached in such a way as to compensate for uneven floors.

**Specification**  
Cup: PA-GF black  
Bolt/locknut: 8.8 steel, zinc-coated



Order data	Order number
------------	--------------

MxL	D	H	F	Order number
M10x70	50	30	2500 N	B42-50
M10x122	50	30	2500 N	B42-00
M14x65	50	25	3000 N	B42-54
M14x115	50	25	3000 N	B42-14
M16x65	50	25	3500 N	B44-50
M16x115	50	25	3500 N	B44-00

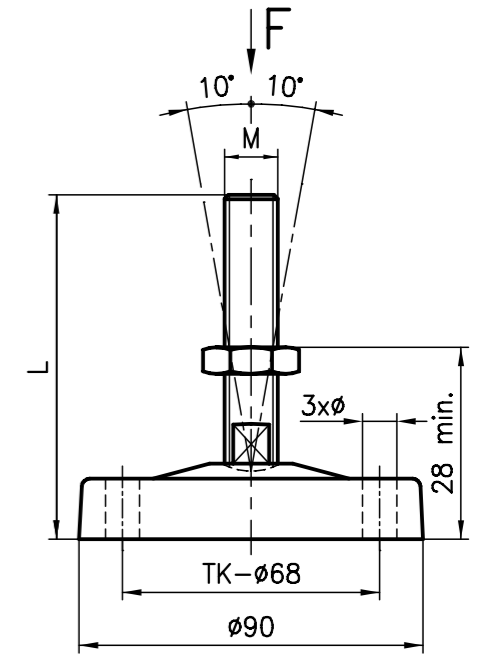

**Specification**  
Cup: PA-GF black or aluminium  
Bolt: 8.8 steel, zinc-coated



Order data	Order number
------------	--------------

MxL	Ø	F	PA-GF	Aluminium
M14x70	9	4000 N	B45-54	
M14x120	9	4000 N	B45-14	
M16x70	9	5000 N	B45-50	
M16x120	9	5000 N	B45-00	
M14x70	9	8000 N		B45-55
M14x70	-	8000 N		B45-56
M14x120	9	8000 N		B45-03
M14x120	-	8000 N		B45-04
M16x70	9	10'000 N		B45-51
M16x70	-	10'000 N		B45-52
M16x120	9	10'000 N		B45-01
M16x120	-	10'000 N		B45-02

### Levelling feet with shock absorbers

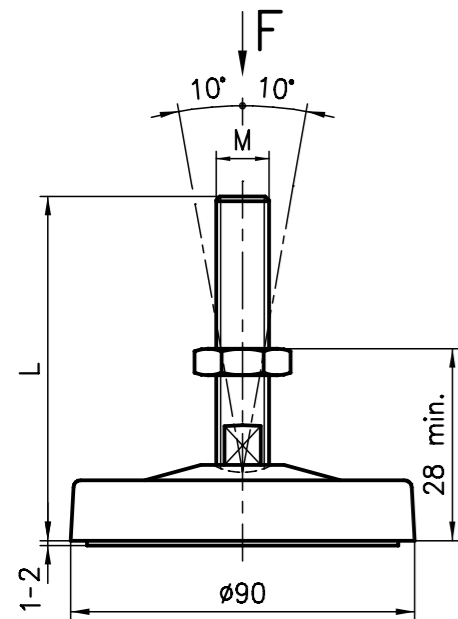

**Application**  
The aluminium levelling foot is available with a special shock absorber insert. This ensures that vibrating structures sit securely on the floor.

**Specification**  
Cup: aluminium  
Roundel:  $\varnothing$  80x18  
Multi-layer, non-slip, vibration-absorbent, composite structure.  
Bolt: 8.8 steel, zinc-coated

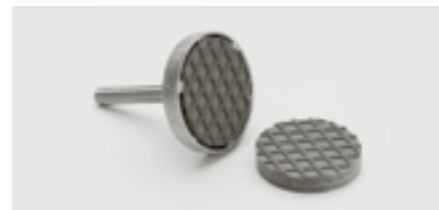

Order data	Order number	
MxL	F	
M14x70	5000 N	B45-56-D
M14x120	5000 N	B45-04-D
M16x70	5000 N	B45-52-D
M16x120	5000 N	B45-02-D

### Electrically conductive levelling feet

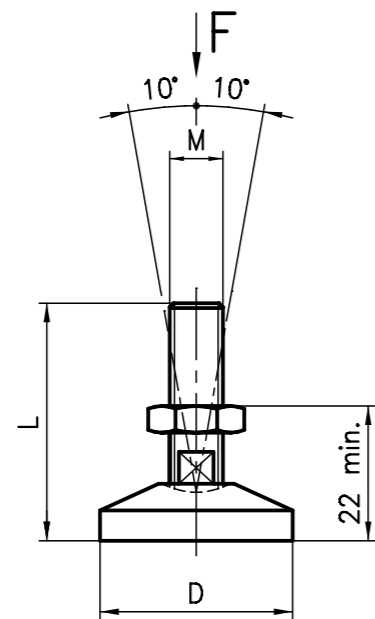

**Application**  
It is essential to use these levelling feet in applications where electrostatic charges must be earthed. (See also PVS connectors with electrical bonding)

**Specification**  
Cup: aluminium raw  
Bolt: aluminium raw



Order data	Order number	
MxL	D	F
M14x65	30	3000 N
M16x115	50	3500 N
M16x115	30	3500 N

### Base plates

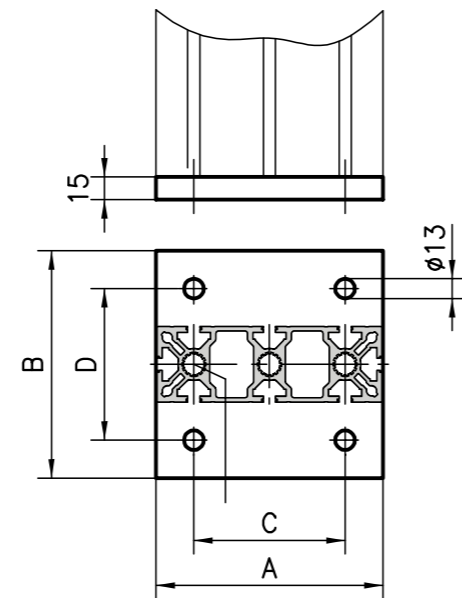

**Application**  
When structures are subjected to heavy loads, structural stability is extremely important. The solid steel base plate meets this requirement in every respect, guaranteeing a high level of safety.

**Specification**  
Steel, gunmetal finish

**Fixing kit\***  
Bolt(s) M16x30



Order data	Order number				
Extrusion	A	B	C	D	
50x50	150	50	120	-	A47-50*
50x150	150	150	100	100	A47-70*
100x100	200	100	150	70	A47-80*
40x40	120	40	90	-	C47-40*
80x80	150	80	120	50	C47-80*

\* Fixing kit: add -S to the order number  
Example: A47-50-S

### Foot plates

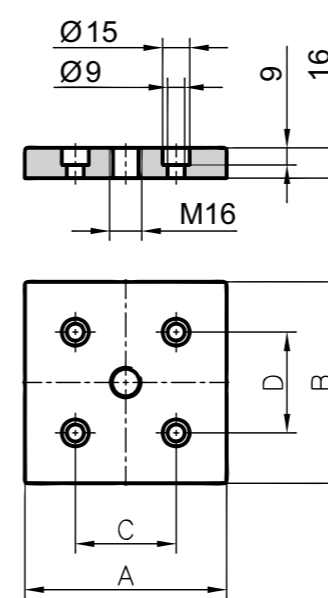

**Application**  
For use with extrusions without a central core hole when fixing levelling feet and casters.

**Specification**  
Zinc die-cast, galvanised

**Fixing kit\***  
Screws and threaded inserts

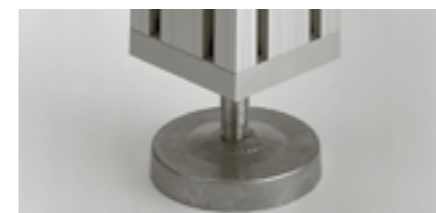

Order data	Order number				
Extrusion	A	B	C	D	
100x00	100	100	50	50	A80-20*
90x90	90	90	45	45	E80-20*
80x80	80	80	40	40	C80-20*
45x90	45	90	-	45	E80-24*
40x80	40	80	-	40	C80-24*

\* Fixing kit: add -S to the order number  
Example: A80-20-S

Other dimensions on demand.

### Floor bolting bracket

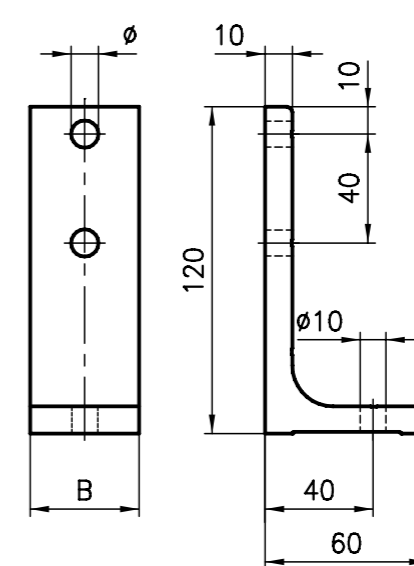

**Application**  
A floor bolting bracket is used when a system has been aligned and has to be bolted to the floor. It is very easy to use because its height can be adjusted in the extrusion slot and the bracket can be easily secured to the floor using anchor bolts.

**Specification**  
Aluminium, anodised in natural colours

**Fixing kit\***  
2 screws, 2 threaded plates, 2 washers



Order data	Order number		
Extrusion base	B	ø	
50/45/40	40	8.5	A47-00*
30	30	6.5	B47-00*

\* Fixing kit: add -S to the order number  
Example: A47-00-S

### Gusset plate

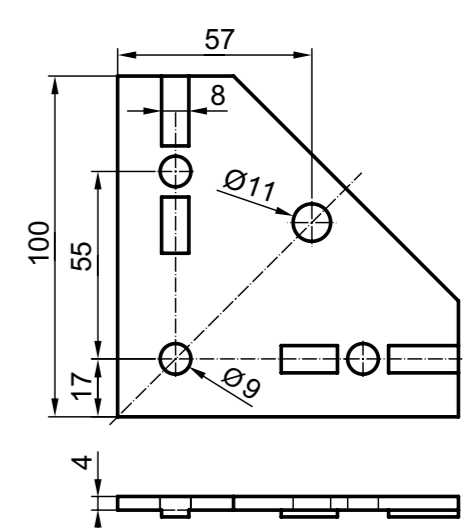

**Application**  
With the gusset plate you create a reinforced connection of 2 extrusions. The punched beads position the extrusion. In the middle hole swivel castors can be mounted offset inwards.

**Specification**  
steel, blue galvanised

suitable for base 40/45/50



Order data	Order number
Gusset plate 100x100x4	C30-50

### Double bolting bracket

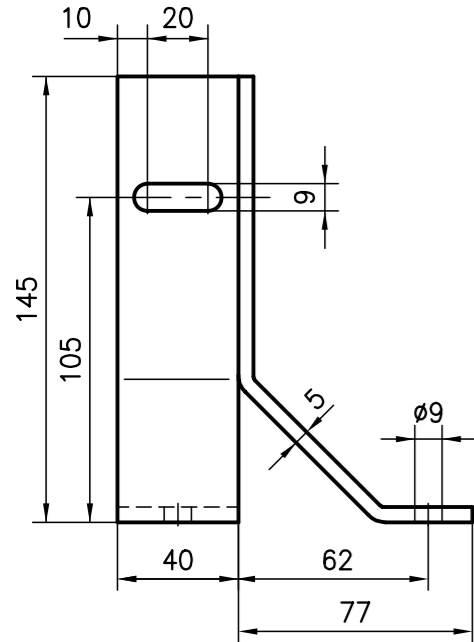

**Application**

An advance on the normal floor bolting bracket, with the added advantage that it can be used together with large levelling feet (Ø 90). The double bolting bracket also secures the supporting extrusions in two directions.

**Specification**

Steel, powder-coated in black



Order data	Order number
Double bolting bracket	A47-20(-S)*

### Single bolting bracket

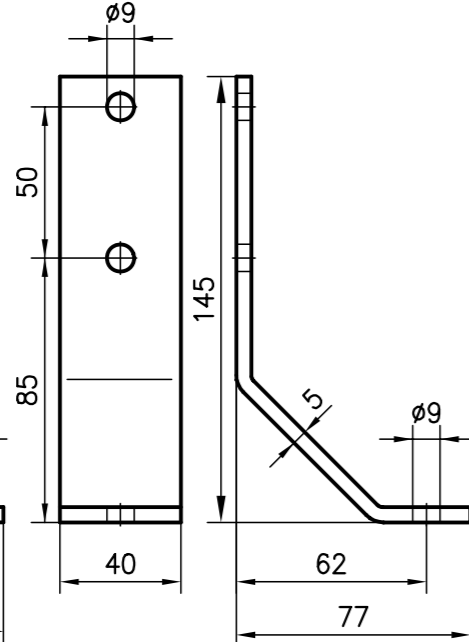

**Application**

For easy fixing to the floor. As with the double bolting bracket, this single bolting bracket can be combined with a levelling foot.

**Specification**

Steel, powder-coated in black

**Fixing kit\***

- 2 screws
- 2 (3) threaded plates
- 2 washers

\*Fixing kit: add -S to the order number

Order data	Order number
Single bolting bracket	A47-21(-S)*

### Single bolting bracket reinforced

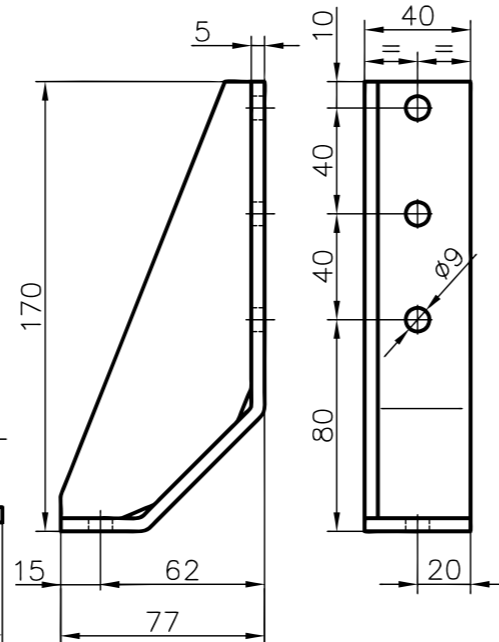

**Application**

Same as the aluminium floor bolting bracket with the added advantage that it can be used together with large levelling feet Ø90.

**Specification**

Steel, powder-coated in black

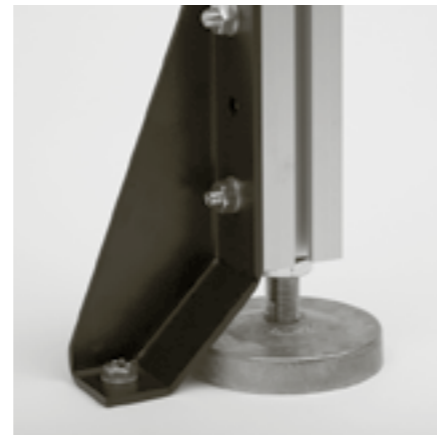

Order data	Order number
Single bolting bracket	A47-22(-S)*

### Ground anchoring bracket

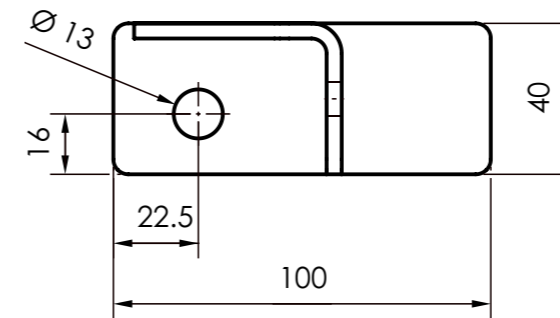
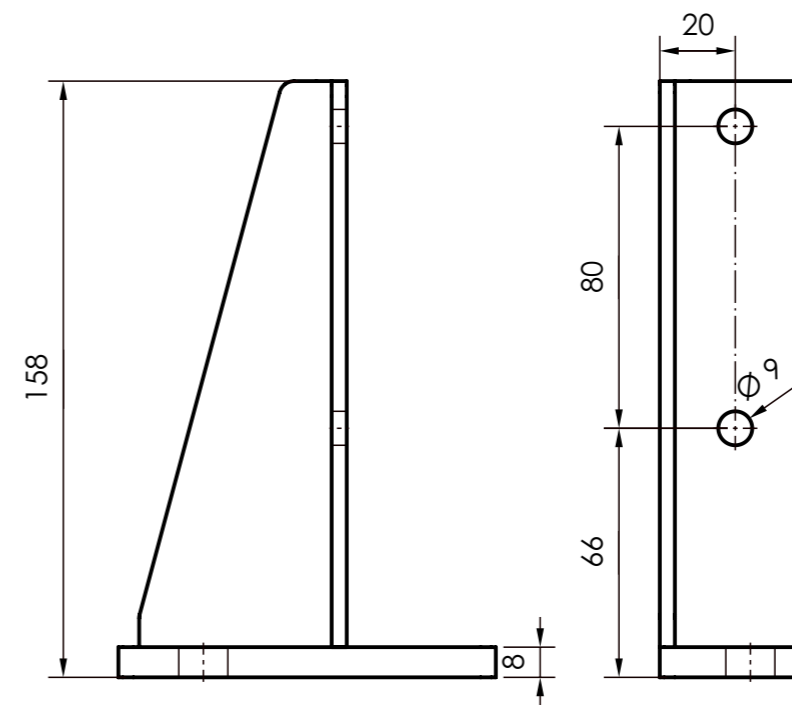

**Application**

The ground anchoring bracket enables simple floor mounting of 40x40 and 40x80 aluminium extrusion including levelling option.

**Specification**

Steel, grey powder-coated

**Fixing kit\***

- 2 T-bolts
- 1 levelling screw M10x60
- 1 threaded insert A33-20

\*Fixing kit: add -S to the order number

Order data	Order number
Ground anchoring bracket	C47-31(-S)*

## Leg bolt-down socket

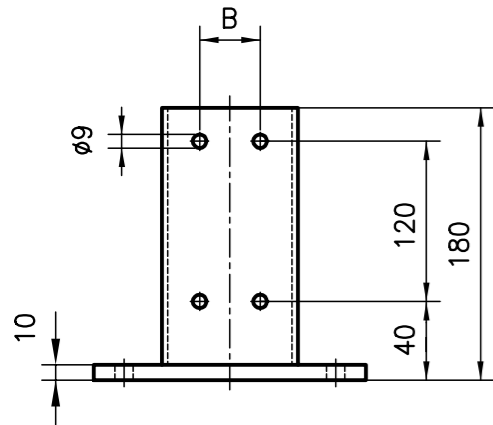

### Application

The bolt-down socket is used in applications where the legs have to be very firmly secured to the ground. The extrusion can be adjusted easily within the guide socket and can be secured in place using the fixing kit included. The bolt-down socket should be chosen, from the three available, to suit the space available.

### Specification

Steel, powder-coated in black

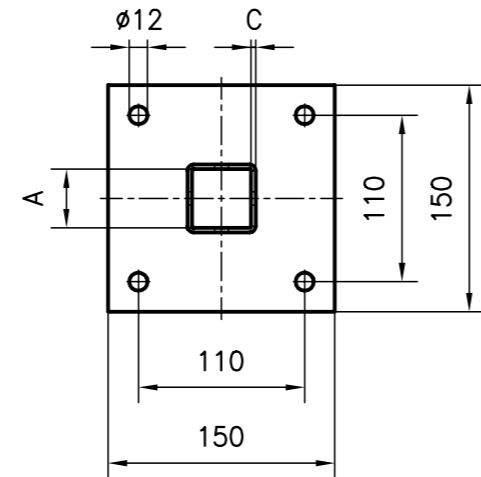
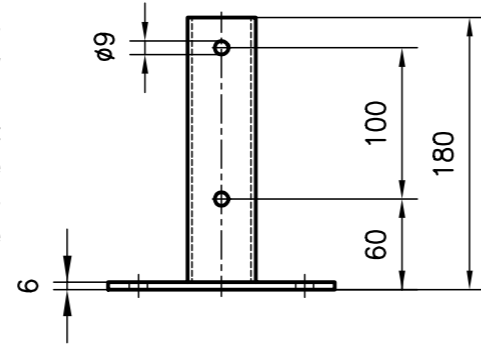
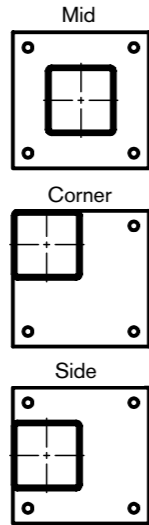
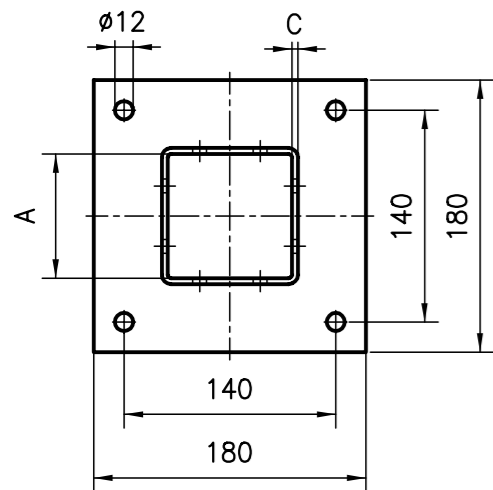

### Fixing kit\* (applies to all types)

8 cylinder screws, 8 threaded plates  
8 washers



### Fixing kit\* (applies to all types)

4 cylinder screws, 4 threaded plates,  
4 washers

Order data	Order number	Order data	Order number
Extrusion 80x80		Extrusion 40x40	
A 82	C47-36	A 41	C47-32
B 40	C47-37	B -	C47-33
C 4	C47-38	C 2	C47-34
Type Middle	C47-36-S	Type Middle	C47-32-S
		Type Corner	C47-33
		Type Side	C47-34
*Fixing kit		*Fixing kit	C47-32-S
Extrusion 90x90		Extrusion 50x50	
A 92	E47-36	A 52	A47-32
B 45	E47-36-S	B -	A47-33
C 4		C 4	A47-34
Type Middle		Type Middle	A47-32-S
		Type Corner	
		Type Side	
*Fixing kit		*Fixing kit	

## Castors

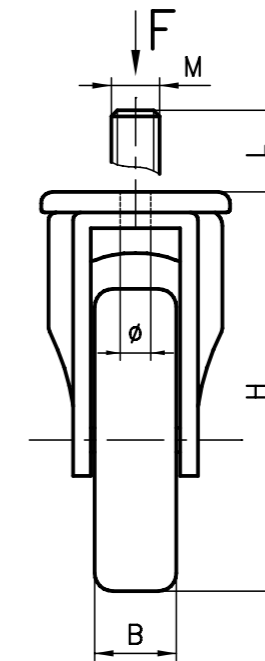
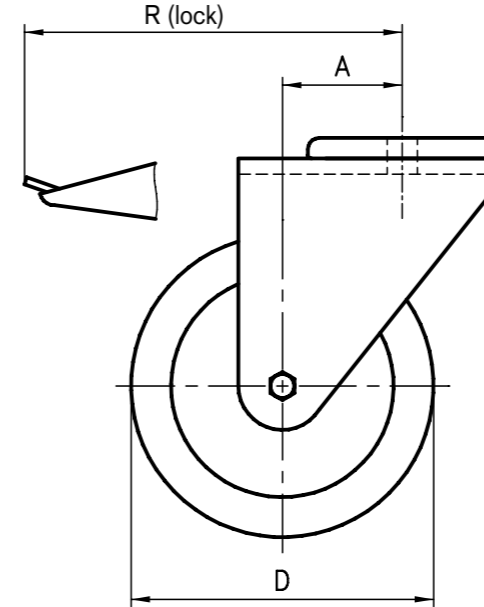

## Non-swivel castors

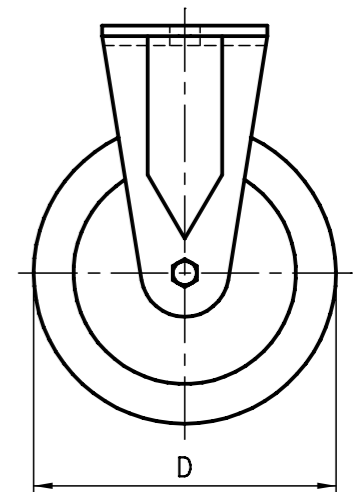

### Application

Can be used in any application where mobility is required. There are four diameters of wheels available (with or without locks) depending on the load capacity required. Swivel and non-swivel castors have the same load capacity. (F)

The castors can be simply attached to the extrusions either with an M10 bolt or by means of an M16 / 14x25 threaded stud. Range of application -17° to +60°C

### Specification

Fork: Zinc-coated steel,  
Ball bearing  
Wheel: Rubber tyre 87° Shore,  
Ball bearing  
with «fender» made of POM light gray

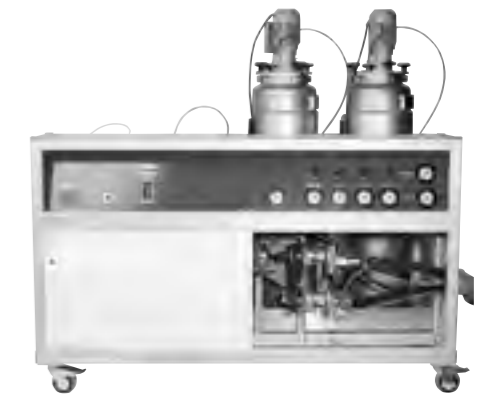

Order data	Order number	Order data	Order number
Castor		Castor	
D 50	B48-50	D 75	B48-75
B 18	B48-54	B 25	B48-74
H 69	B48-75	H 100	B48-100
A 24	B48-74	A 44	B48-100
R 72	B48-100	R 118	B48-125
Ø / MxL Ø 10.3	B49-50	Ø / MxL Ø 10.3	B49-75
F 400 N	B49-54	F 700 N	B49-74
	B49-75	F 800 N	B49-100
	B49-74	F 800 N	B49-100
	B49-100	F 1200 N	B49-101*
	B49-101*	F 1000 N	B49-125
	B49-125	F 1000 N	B49-125
	A48-125		A49-125

For load of >800N we recommend castors with PO-wheels.

Castors with PO-Wheels and other sizes, heavy duty and anti-static castors are available on request.

\* PO wheels

Order data	Order number
Non-swivel castors	
D 75	B48-77*
B 25	B48-78*
H 98	B48-107
Ø / MxL Ø 11	B48-107
Ø / MxL M14x25	B48-108
Ø / MxL Ø 12	B48-127
Ø / MxL M16x25	B48-127
Ø / MxL M16x25	B48-128

\*incl. washer of 2 mm

Load data F for non-swivel castor:

ø75 = 750N  
ø100 = 1000N  
ø125 = 1000N



### Casters with backplate

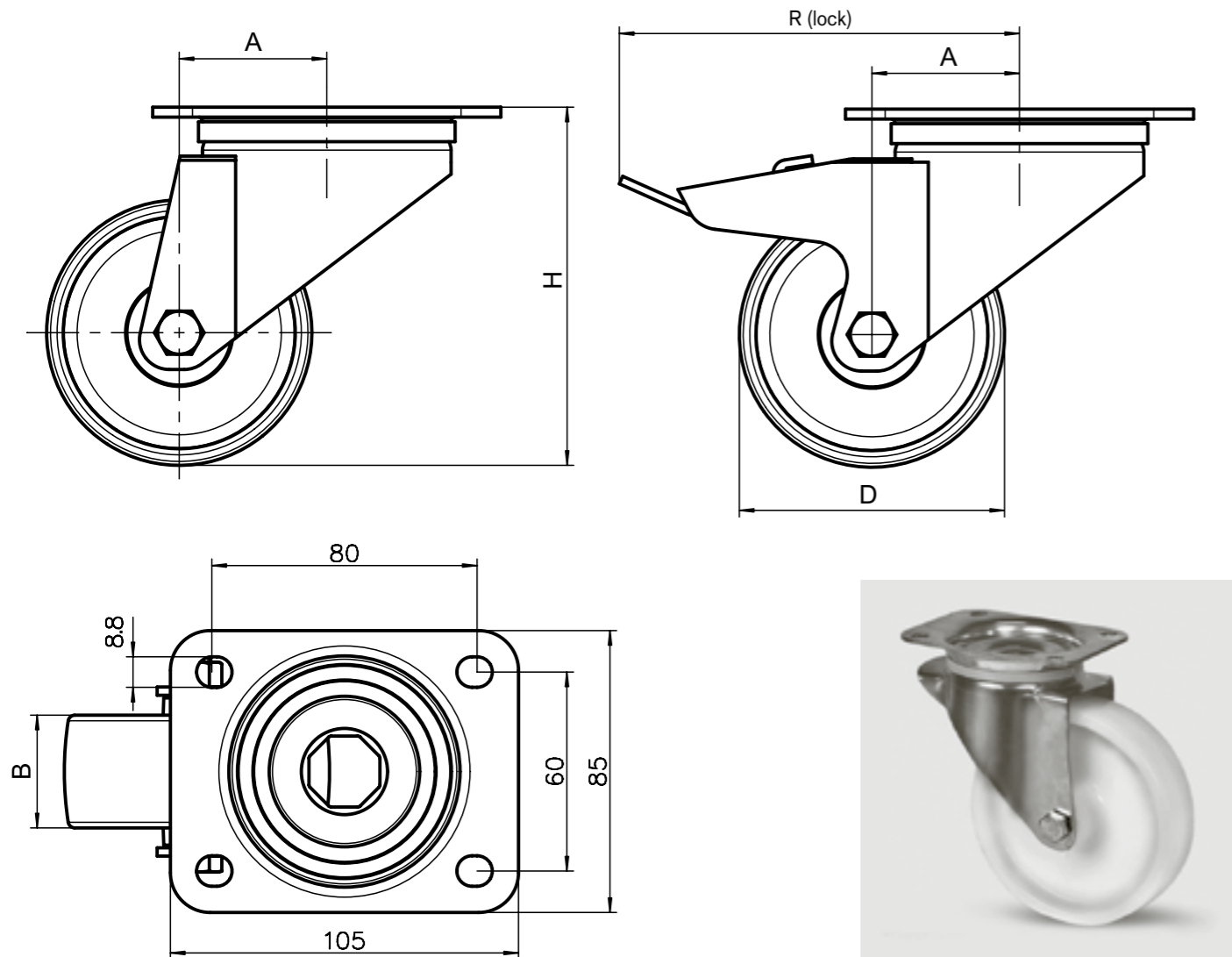

**Application**

These casters with backplate can be screwed directly into the extrusion slot. Can even be used on workstations or storage racks, any application where mobility is required.

**Specification**

Fork: zinc-coated steel, ball bearing  
 Wheel: PO, ball bearing

Order data	Order number							
	D	B	H	A	R	F	no lock	with lock
Castor	80	33	108	44.5	115	2000N	B48-80	B48-81
Castor	125	40	160	50	120	3500N	B48-126	B49-126

### Rollers

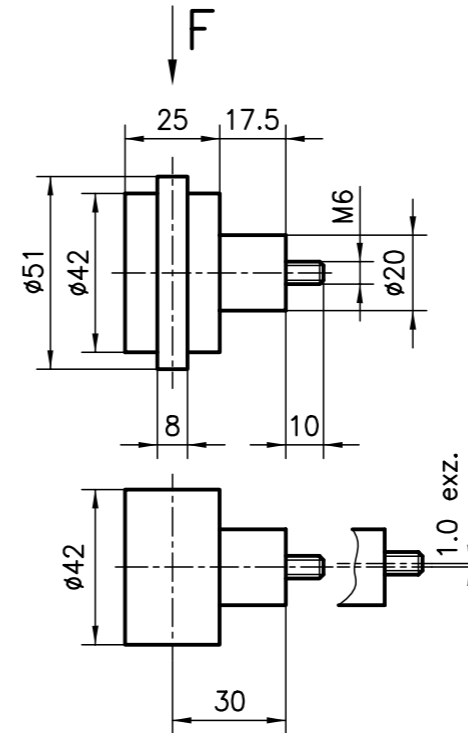

**Application**

This roller is suitable for heavy sliding doors, as a wheel for workpiece holders or for general structures which have to move freely. Insert the guide flange into the extrusion slot. Fit the flat roller onto the other side. This creates the perfect trolley/rail combination independent of the extrusion tolerance.

**Specification**

Plastic roller, ball bearing mounted, steel spacer, gunmetal finish  
 Radial load  
 F = 500 N

Order data	Order number	
	Centric	Eccentric
Roller with guide flange	C48-00	C48-01
Roller without guide flange	C48-10	C48-11

**Application**

This ball bearing-mounted roller is mainly used in an assembly with the trolley extrusion, although it can also be attached directly to any extrusion.

**Specification**

PA 6 black  
 2 deep groove ball bearings with cover disks  
 F = 150 N



Order data	Order number
Roller PA	B48-05

### Concave roller

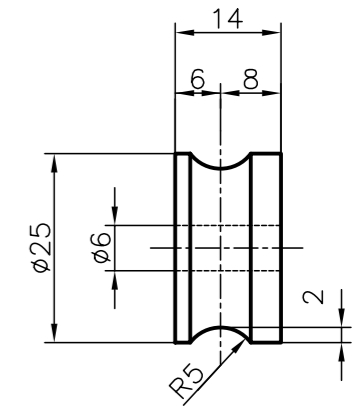

**Application**

This ball bearing-mounted roller is mainly used in an assembly with the trolley extrusion. It can however also be attached directly to any extrusion. The corresponding aluminium guide extrusion type B19-8 is used to produce an inexpensive roller guide in next to no time.

**Specification**

Plastic PA 6 black  
 2 deep groove ball bearings with cover disks  
 F = 150 N

Order data	Order number
Roller, concave	B48-10

### Concave double-wheeled trolley

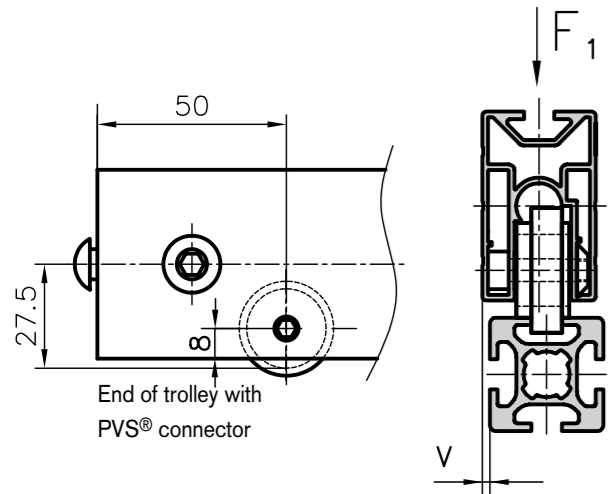

### Double-wheeled trolley

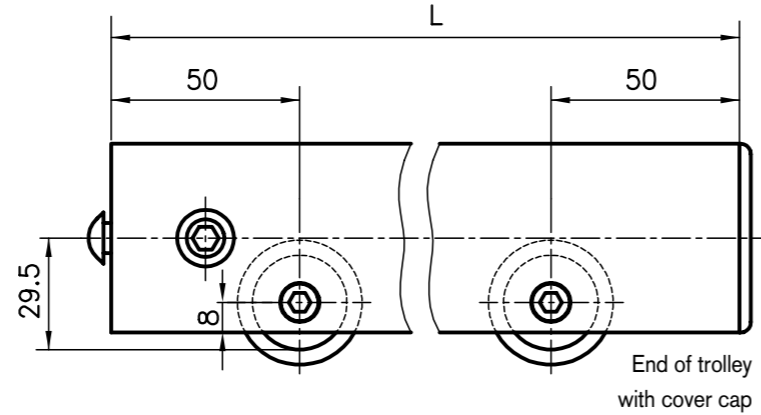

#### Application

A wide range of different applications is possible with the double-wheeled trolley. It provides a simple and mechanically reliable way of creating equipment chassis, sliding doors, lifting devices etc. Any lengths of extrusion can be used. However, the spaces between rollers should not exceed 1000 mm for large trolleys. Trolleys are also available with more than 2 rollers. Using the concave rollers, together with the aluminium extrusion guide B19-8 on page 122, it is easy to produce easy cleaning guides.

#### Parts supplied

Aluminium extrusion with  $\geq 2$  rollers.  
PVS® connector and/or cover caps fitted.

End of trolley (page 89) with PVS® connector

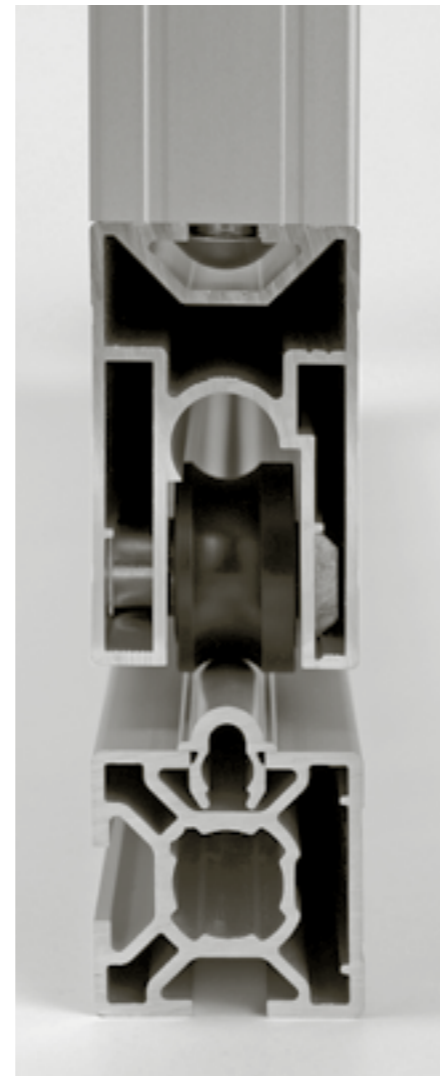
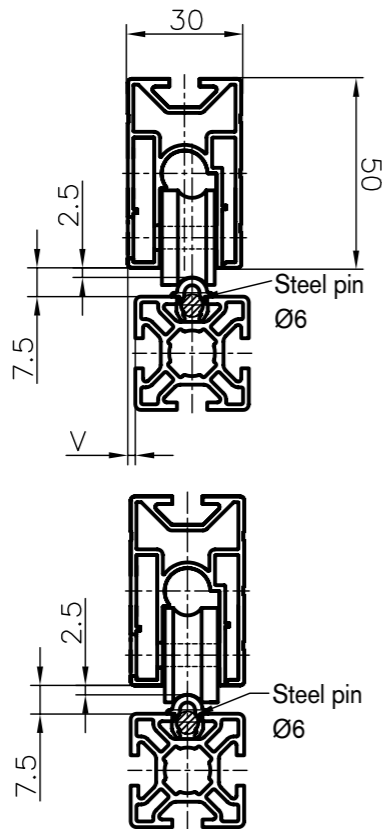

Order data		Order number	
		<b>v = 0 mm</b>	<b>v = 2 mm</b>
Double-wheeled trolley	L= ... with cover caps	B37-52-02-02/...	B37-53-02-02/...
Double-wheeled trolley	L= ... with PVS® connector	B37-52-10-10/...	B37-53-10-10/...
Concave double-wheeled trolley	L= ... with cover caps	B37-12-02-02/...	B37-13-02-02/...
Concave double-wheeled trolley	L= ... with PVS® connector	B37-12-10-10/...	B37-13-10-10/...

### Plastic slide extrusions

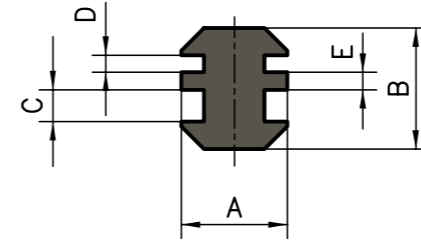

#### Specification

Black PE  
Sliding friction coefficient: 0,2  
Heat resistance to DIN 53461:  
-250 °C to 100 °C  
Indentation hardness to DIN 53456:  
39N/mm<sup>2</sup>

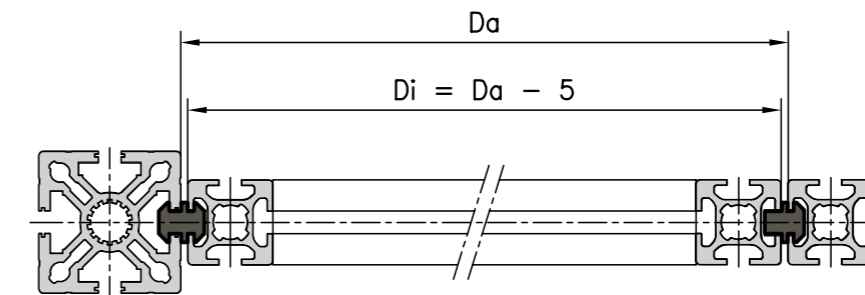

#### Measurement data

Extrusion base	A	B	C	D	E
50/40	21	21	4.1	4.1	2.3
50/40-30/20	14	16	4.1	2.2	2.3
30/20	14	14	2.2	2.2	2.3



#### Order data

Order data	Order number
Plastic slide extrusion	Base of 50/45/40
Standard length 5000 mm	A39-00-5M
Cut to length	A39-00-02-02/ ...
Plastic slide extrusion	Base of 50/45/40 - 30/20
Standard length 5000 mm	AB39-00-5M
Cut to length	AB39-00-02-02/ ...
Plastic slide extrusion	Base of 30/20
Standard length 5000 mm	B39-00-5M
Cut to length	B39-00-02-02/ ...

#### Application

Ideal for any shape of slide guide, for instance for sliding doors or drawer runners. Simply push the slide extrusion into the aluminium extrusion slots – you can create a perfect, hard-wearing guide as easily as that. Make the inner frame 5 mm smaller than the inner width of the outer frame. It is also ideal for static extrusion assemblies.

#### Order data

Order data	Order number
Plastic slide extrusion	Base of 50/45/40
Standard length 5000 mm	A39-05-5M
Cut to length	A39-05-02-02/...
with 2mm offset	
Standard length 5000 mm	A39-02-5M
Cut to length	A39-02-02-02/...
Plastic slide extrusion	Base of 30/20
Standard length 5000 mm	B39-05-5M
Cut to length	B39-05-02-02/...
with 2mm offset	
Standard length 5000 mm	B39-02-5M
Cut to length	B39-02-02-02/...

#### Base of 50/45/40

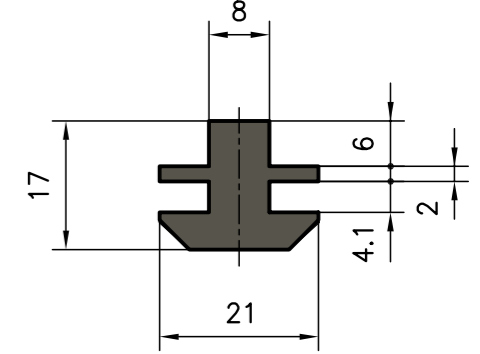

#### Base of 50/45/40 with offset

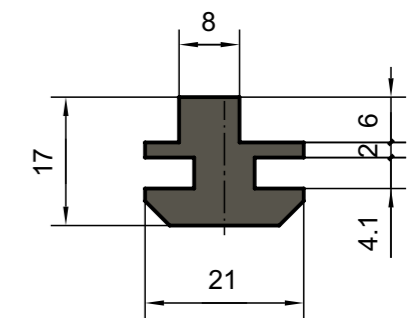

#### Base of 30/20

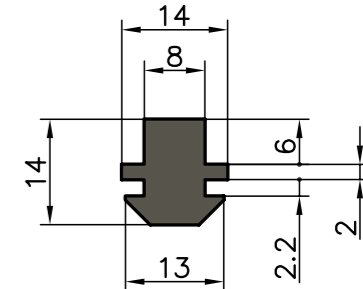

#### Base of 30/20 with offset

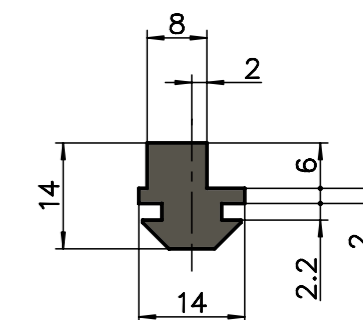

## Plastic slide extrusions

Base of 50/45/40

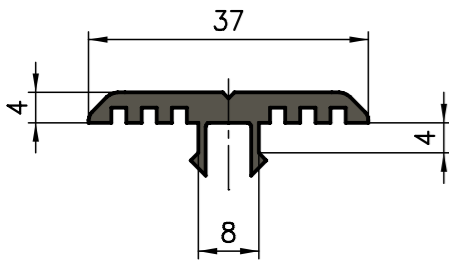

Base of 30

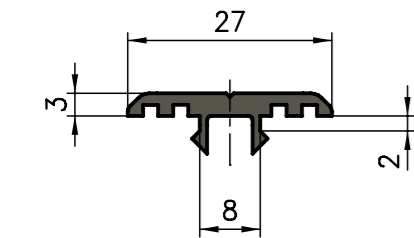

### Application

This slide extrusion is mounted on the extrusion, acting as a sliding carrier for goods or pallets. The slide extrusion can also be used as a protective strip.

### Specification

PP with Talkum 30%, black

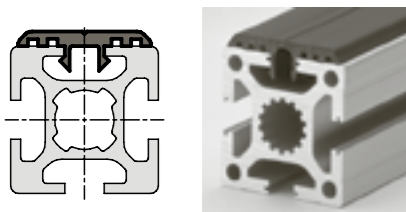

Order data	Order number
Plastic slide extrusion	Base of 50/45/40
Standard length 5000 mm	AC39-20-5M
Cut to length	AC39-20-02-02/...
Plastic slide extrusion	Base of 30
Standard length 5000 mm	B39-20-5M
Cut to length	B39-20-02-02/...

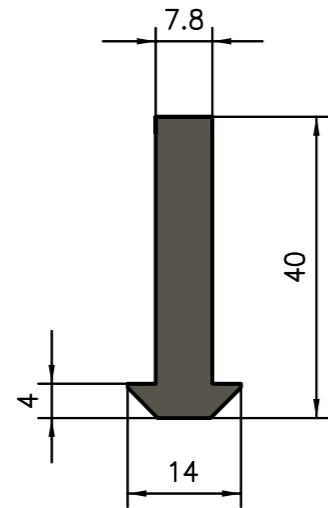

### Application

For single sliding doors, suspended fittings, cable supports and many other uses. Fits all standard KANYA extrusions.

### Specification

PE, black



Order data	Order number
Plastic slide extrusion	Base 50/45/40/30/20
Standard length 5000 mm	A69-0-5M
Plastic slide extrusion	Base of 50/45/40/30/20
Cut to length	A69-0-02-02/...

## Sliding hook

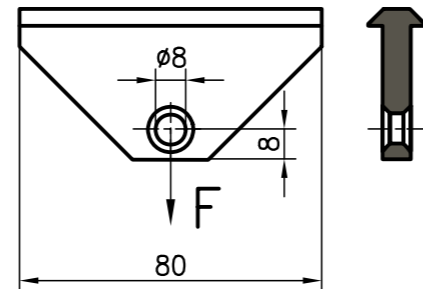

### Application

The sliding hook is ideally suited for suspended tool applications or as a cable guide. It is simply pressed into the extrusion slot and moves freely. Other lengths of multiple-hole versions are available on request.

### Specification:

Slider: PE, black  
made from a plastic slide extrusion, A69-0-00  
load-bearing capacity: F = 300 N  
Spring hook: chromium-plated steel

Order data	Order number
No spring hook	A69-00
With a spring hook	A69-01

## Cable ducts

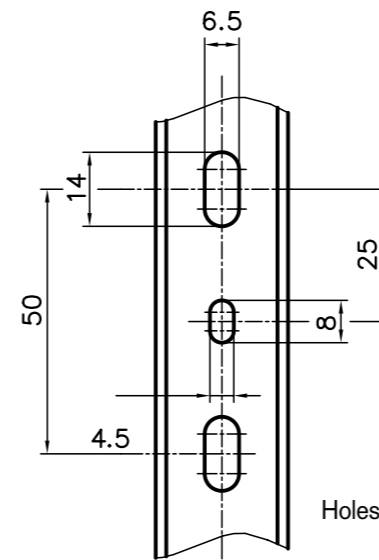
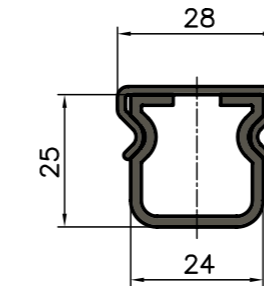

Holes only in slotted model

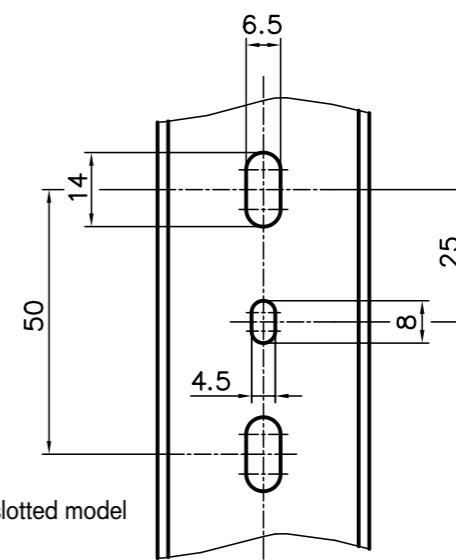
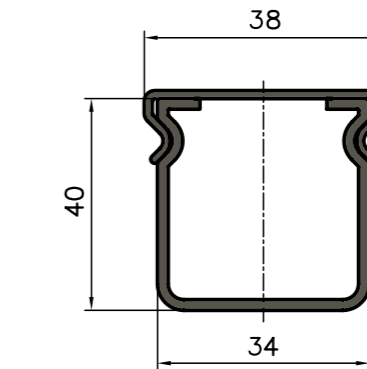

### Application

The cable ducts are placed directly onto the extrusions and are secured using either the retaining clips or extrusion nuts available. The duct is easy to open or close any time as it is fitted with a press-on cover. The slotted sides enable cables to be fed in and out at any point.

### Specification

UPVC, light grey  
(standard length: cable ducts 2000 mm)

Order data	Order number
<b>Cable ducts</b>	<b>closed</b> <b>slotted</b>
40 mm wide	Standard length      C38-00-2M      C38-01-2M
	auf Länge geschnitten      C38-00-02/...      C38-01-02/...
25 mm wide	Standard length      B38-00-2M      B38-01-2M
	auf Länge geschnitten      B38-00-02/...      B38-01-02/...
Other dimension on demand.	

## Retaining clips

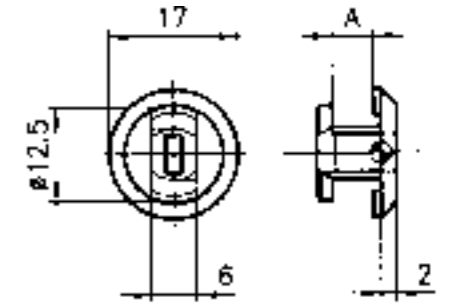

### Application

The quarter turn retaining clips allow the easy fixing of either cable ducts or thin sheet material onto the extrusions Base 50, 45, 40 and 30.

### Specification

PA-GF, black



Order data	Order number
Retaining clips A = 5.5	AC38-20
Retaining clips A = 3.5	B38-20

### «Velcro» Cable ties

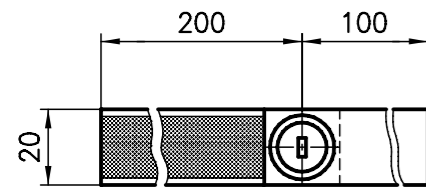

#### Application

This universal cable tie is made from a combination of Velcro material and a retaining clip. The Velcro can be cut to length with scissors. The quarter turn retaining the clip ensures easy fixing to the extrusions Base 50, 45, 40 and 30. On the tie-wrap-base you can fix standard tie wraps. Fix with a M5-screw.



Order data	Order number
«Velcro» Cable ties	Extrusion base 50/45/40 30 B50-50 B50-53

### Tie wrap «base»

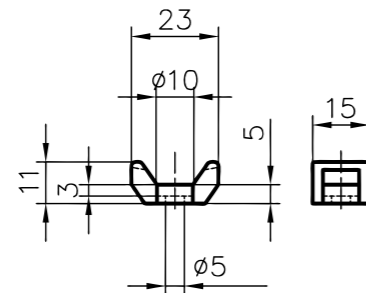

#### Specification

Clips: glass-filled Polyamide (PA-GF) black  
Ribbon: Velcro black  
Tie wrap Base: PA black



Order data	Order number
Tie wrap «base»	Extrusion base 50/45/40/30/20 B50-55

### Cross-cable tie block

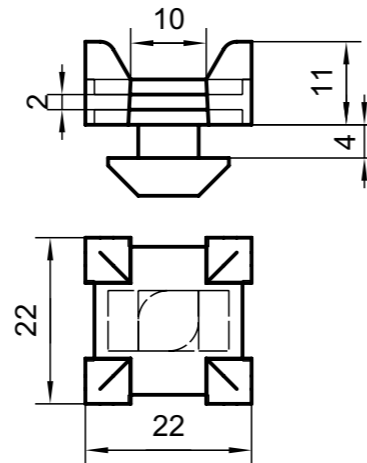

#### Application

The cross-cable tie block can be screwed into the nut. The block is locked after 90° rotation. Commercially available cable ties can be attached.

#### Specification

PA-GF, black



Order data	Order number
Cross-cable tie block	Extrusion base 40/45/50 B50-56

### Aluminium cable ducts 40x40, 40x80, 80x80

#### Application

The cable ducts can be placed directly on to the extrusions and secured using screws and threaded plates / extrusion nuts. The duct is easy to open or close any time as it is fitted with a press-on cover.

#### Description

Size 40x40mm, 40x80 and 80x80

#### Specification

Anodised aluminium

#### Aluminium cable duct with cover

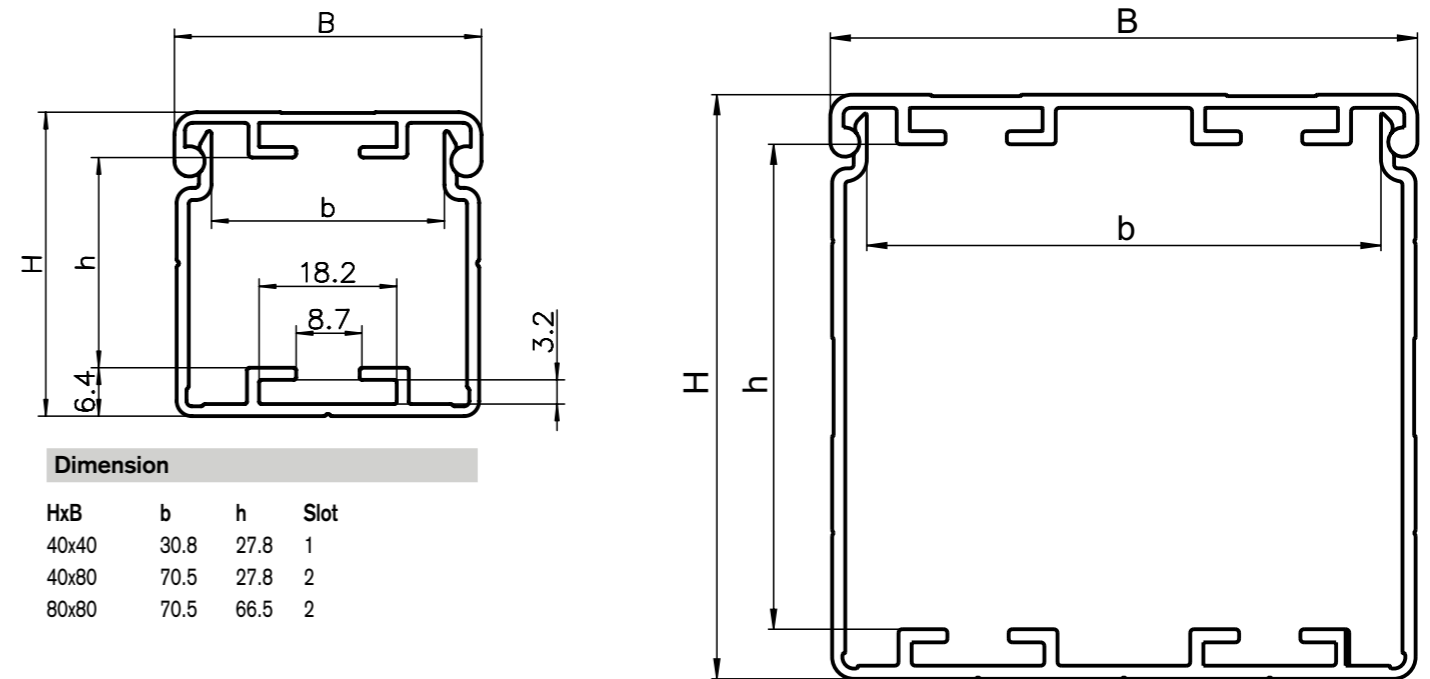
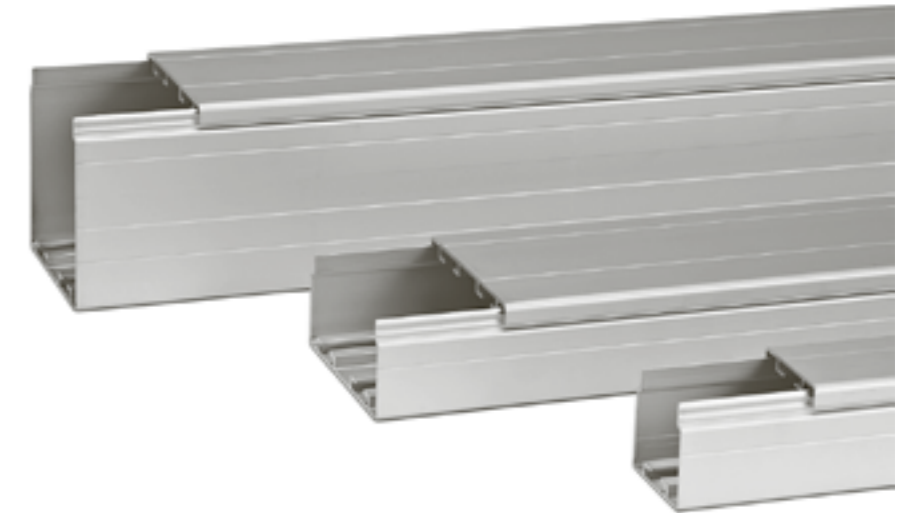

Dimension			
HxB	b	h	Slot
40x40	30.8	27.8	1
40x80	70.5	27.8	2
80x80	70.5	66.5	2

Order data	Order number
Aluminium cable duct 40x40 (B=40, H=40) incl. cover	
Standard length 6000 mm	C38-11-6M
Cut to length	C38-11-02-02/...

Order data	Order number
Aluminium cable duct 40x80 (B=80, H=40) incl. cover	
Standard length 6000 mm	C38-21-6M
Cut to length	C38-21-02-02/...

Order data	Order number
Aluminium cable duct 80x80 (B=80, H=80) incl. cover	
Standard length 6000 mm	C38-31-6M
Cut to length	C38-31-02-02/...

## Front cover

### Application

A range of different covers and designs are available for the aluminium cable ducts 40x40, 40x80 and 80x80 to cover the open cross-sections. Available with or without outlet holes for possible cable passage.

Specification: Zinc-coated steel

Parts supplied:

Front cover with adjusting screws

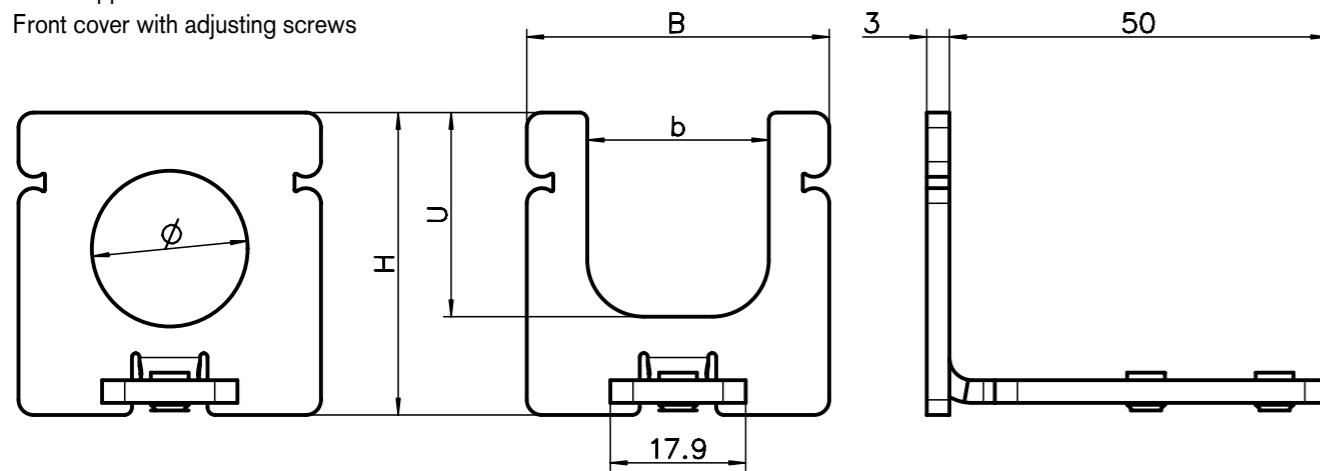
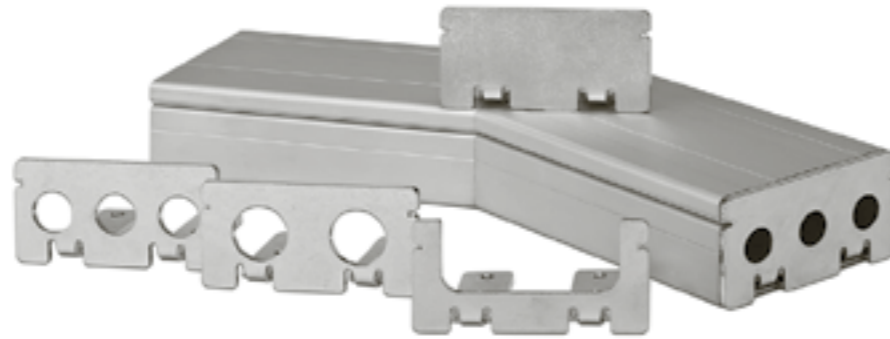

Design with Ø 40x40



Design with U-shape 40x80



Closed design 80x80

Design 40x40	Order number	Design 40x80	Order number	Design 80x80	Order number
closed	C38-14	closed	C38-24	closed	C38-34
U-shape 24x27mm (Uxb)	C38-15	U-shape 26x60mm (Uxb)	C38-25	U-shape 60x66mm (Uxb)	C38-35
1x Ø20.6	C38-18	3x Ø16	C38-26	4x Ø16	C38-36
		2x Ø20.6	C38-28	4x Ø20.6	C38-38

## Cable duct connector

### Application

The connectors are used to extend the cable ducts and create a 90° mitred connection (other angles on request). 2 connectors are required for the aluminium cable ducts 40x80 and 80x80. The threaded pins used to fix the ducts are included with the parts supplied.

Specification: zinc-coated steel  
Adjusting screws: M5

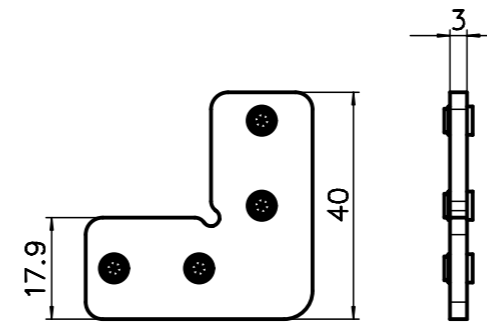

Connector, straight

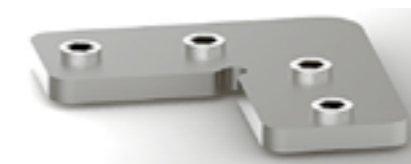

Connector, 90°, other angles on request

Order data	Order number
Connector, 90°	C38-90
Connector, straight	C38-91

## Covering cap for front cover

### Application

The covering cap is used to cover unnecessary openings on the front plates.

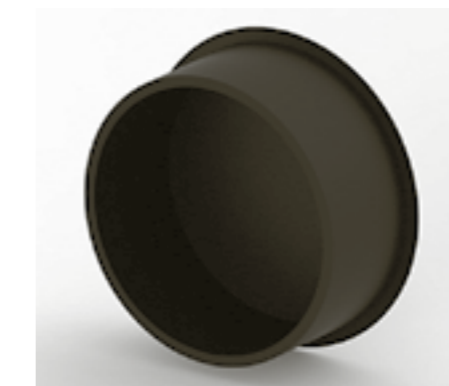
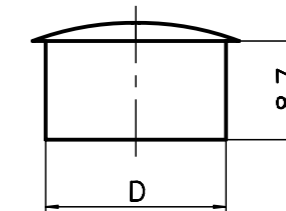
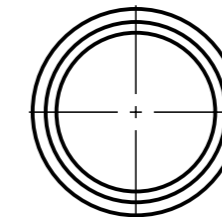

Plastic, black

Order data	Order number
Ø 16	C38-46
Ø 20	C38-47

## Cable passage to front cover

### Application

This edge protection is used at places where cables need to be fed through the cable duct on the front face. Available for the relevant holes in the front covers.

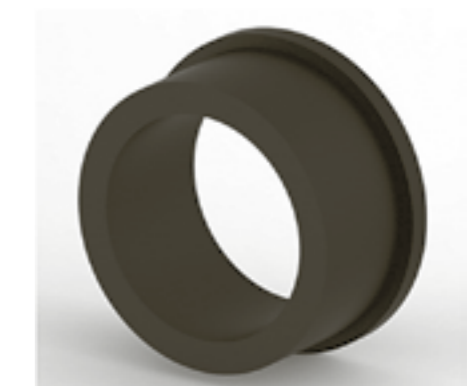
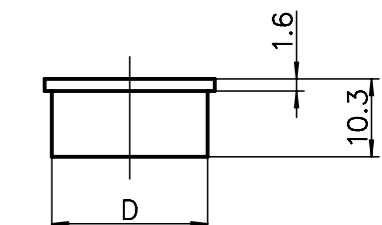
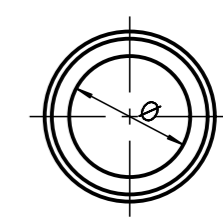

Plastic, black

Order data	Order number
D= 16 Ø 12.7	C38-56
D= 20 Ø 16	C38-57

## Composite panels

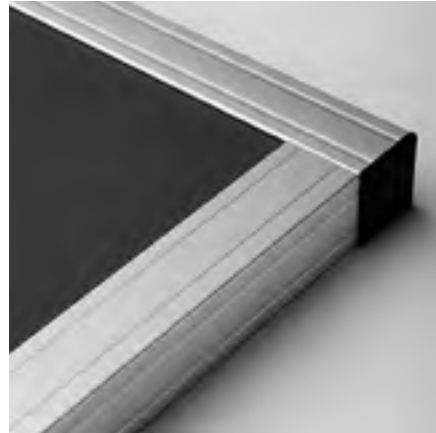

## Micro chipboard



## Acrylic glass

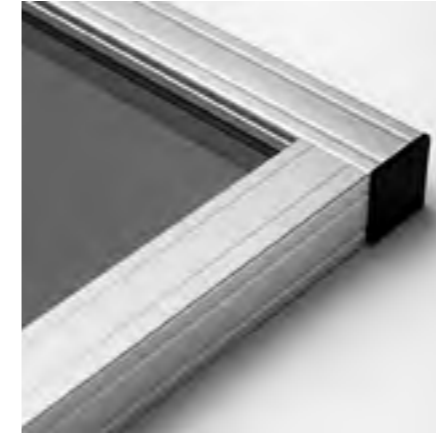

## Polycarbonate



### Application

Intrinsically high strength enclosure panels. The thicknesses of the panels fit the narrow slots of the different 30 mm base extrusions, guaranteeing a tidy finish.

### Application

This inexpensive panelling is inserted directly into the 8 mm slot on extrusions. The panels are lined with a white film on either side. They are highly fire-retardant and are used most commonly in the construction of exhibition stands and shop fittings.

### Application

For machine safety enclosures, room partitions and display cases. (suitable for metal machining). Hot forming possible using special tool.

### «DIBOND» specification

Composite panel lined on either side with 0.3 mm thick aluminium sheets. Stove-enamelled on either side.

Thickness: 2.0 mm

Colour: aluminium metallic finish

Size: max. 1250 x 3050 mm

Weight: 2.9 kg/m<sup>2</sup>

Thickness: 3.0 mm

Colour: white, similar to RAL 9016  
black, similar to RAL 9005

Size: max. 1500 x 3050 mm

Weight: 3.0 mm: 3.8 kg/m<sup>2</sup>

Thickness: 4.0 mm

Colour: Alu-metallic

Size: max. 1500 x 3100mm

Weight: 4.75 kg/m<sup>2</sup>

### «DILITE» specification

Composite panel lined on either side with 0.2 mm thick aluminium sheets.

Thickness: 2.0 mm

Colour: white, similar to RAL 9016  
and aluminium metallic finish

Size: max. 1250 x 3050 mm

Thickness: 3.0 mm

Colour: white, similar to RAL 9016

Size: max. 1500 x 3050 mm

### Specification

Plastic-coated pressboard.

Highly fire-retardant according to DIN 4102

Thickness: 8 mm

Size: max. 1390 x 2070 mm

Colour: white

Weight: 5.2 kg/m<sup>2</sup>

### Specification for acrylic glass

Colours: clear as glass, or on request

Thicknesses: 3, 4, 5, 6, 8 mm

Size: max. 2000 x 3000 mm

Weight: 3 mm: 3.55 kg/m<sup>2</sup>

4 mm: 4.70 kg/m<sup>2</sup>

5 mm: 5.90 kg/m<sup>2</sup>

6 mm: 7.10 kg/m<sup>2</sup>

8 mm: 9.45 kg/m<sup>2</sup>

### Application

This panel is extremely impact-resistant and is used for windows and doors in safety guards. Metal machining and cold or hot forming is possible. We can provide blank cuts or ready-machined panels.

### Specification for polycarbonate

Colours: clear as glass

Thicknesses: 3, 4, 5, 6, 8 mm

Size: max. 2000 x 3000 mm

Weight: 3 mm: 3.60 kg/m<sup>2</sup>

4 mm: 4.80 kg/m<sup>2</sup>

5 mm: 6.00 kg/m<sup>2</sup>

6 mm: 7.20 kg/m<sup>2</sup>

8 mm: 9.60 kg/m<sup>2</sup>

Order data	Order number
------------	--------------

DIBOND 2 mm	A51-12 A x B
-------------	--------------

DIBOND 3 mm, state colour	A51-13 A x B
---------------------------	--------------

DILITE 2 mm	A51-32 A x B
-------------	--------------

DILITE 3 mm	A51-33 A x B
-------------	--------------

DIBOND 4 mm	A51-14 A x B
-------------	--------------

Order data	Order number
------------	--------------

Micro dense fibreboard	A50-58 A x B
------------------------	--------------

Order data	Order number
------------	--------------

Acrylic glass 3 mm	A50-13 A x B
--------------------	--------------

Acrylic glass 4 mm	A50-14 A x B
--------------------	--------------

Acrylic glass 5 mm	A50-15 A x B
--------------------	--------------

Acrylic glass 6 mm	A50-16 A x B
--------------------	--------------

Acrylic glass 8 mm	A50-18 A x B
--------------------	--------------

Order data	Order number
------------	--------------

Polycarbonate 3 mm	A50-33 A x B
--------------------	--------------

Polycarbonate 4 mm	A50-34 A x B
--------------------	--------------

Polycarbonate 5 mm	A50-35 A x B
--------------------	--------------

Polycarbonate 6 mm	A50-36 A x B
--------------------	--------------

Polycarbonate 8 mm	A50-38 A x B
--------------------	--------------

### PET-G



#### Application

This transparent panel is food-safe and can be used in clean-room applications and medical technology. Metal machining and cold or hot forming is possible

#### Specification for Pet-G

impact-resistant, oil-resistant, food-safe

Colour: clear as glass, transparent  
 Thicknesses: 3, 4, 5, 6, 8 mm  
 Size: max. 2000 x 3000 mm  
 Weight: 3 mm: 4.14 kg/m<sup>2</sup>  
 4 mm: 5.52 kg/m<sup>2</sup>  
 5 mm: 6.90 kg/m<sup>2</sup>  
 6 mm: 8.28 kg/m<sup>2</sup>  
 8 mm: 11.0 kg/m<sup>2</sup>

Order data	Order number
PET-G plate 3 mm	A50-73 A x B
PET-G plate 4 mm	A50-74 A x B
PET-G plate 5mm	A50-75 A x B
PET-G plate 6 mm	A50-76 A x B
PET-G plate 8 mm	A50-78 A x B

Other plastic plates available on request

### PVC foam plates



#### Application

For enclosures or as shelves for light elements. Metal machining and cold or hot forming is possible. The plastic plates are placed directly in the extrusion slots or mounted using fixing elements such as brackets, Uniblocks or quick-release fasteners.

#### Specification

PVC foamed  
 scratch-proof and impact-resistant  
 oil-resistant  
 highly fire-retardant according to DIN 4102 (self-extinguishing)

Colour: white  
 Thickness: 3, 4, 6, 8 mm  
 Size: max. 2000 x 3000 mm  
 Weight: 3 mm: 2.1 kg/m<sup>2</sup>  
 4 mm: 2.8 kg/m<sup>2</sup>  
 6 mm: 4.2 kg/m<sup>2</sup>  
 8 mm: 5.6 kg/m<sup>2</sup>

Other colours may be supplied on request.

Order data	Order number
PVC foamed 3mm	A50-63 A x B
PVC foamed 4mm	A50-64 A x B
PVC foamed 6mm	A50-66 A x B
PVC foamed 8mm	A50-68 A x B

### Aluminium sheets

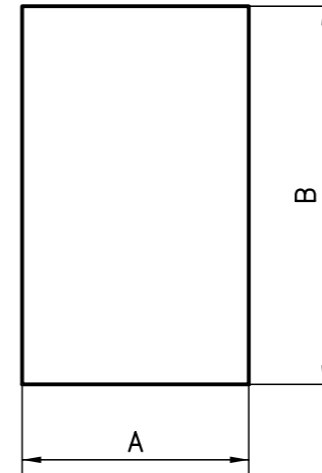

#### Application

All types of enclosures.

#### Specification

Al-sheet 2 and 3.0 mm  
 Anodised in a natural colour, one side with a protective sheet  
 Maximum size: 1000 x 2000mm  
 Other dimensions or powder coated sheets are available on request  
 Weight: Al 2 mm: 5.4 kg/m<sup>2</sup>  
 Al 3 mm: 8.1 kg/m<sup>2</sup>



Order data	Order number
Aluminium sheet, 2 mm	A53-20 A x B
Aluminium sheet, 3 mm	A53-30 A x B

### Expanded metal

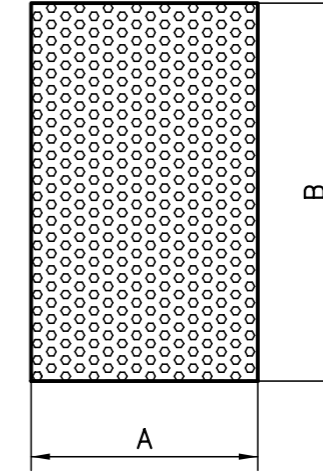

#### Application

The panel for designers with taste – light and attractive, but nonetheless sturdy. Can be used for virtually any purpose.

#### Specification

Aluminium 2 mm, raw  
 Maximum size: 1000 x 2000 mm  
 Weight: 2.0 kg/m<sup>2</sup>



Order data	Order number
Expanded metal	A54-20 A x B

### Perforated sheet

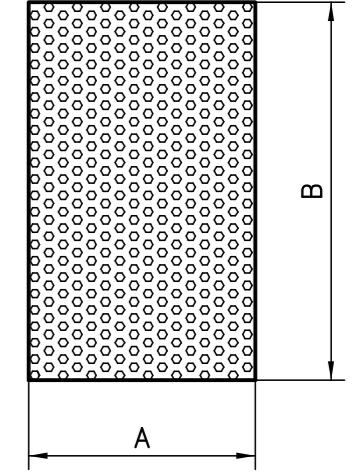

#### Application

The perforated aluminium sheet as a housing surface for ventilated areas. Where heat accumulation can occur, e.g. from a motor or other electronic components. This anodised sheet is also an aesthetic surface element.

#### Specification

Size of hole 8 mm with 11 mm grid in 60° placement.  
 Weight: 2.85 kg/m<sup>2</sup>  
 Size: 952 x 2000 mm  
 Surface: bright rolled

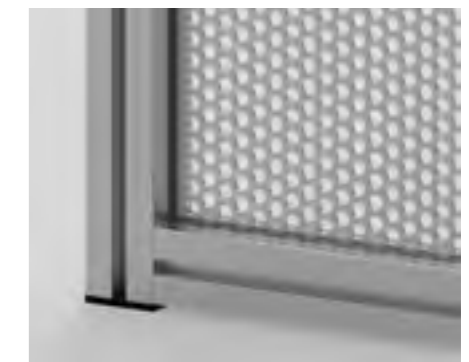

Order data	Order number
Perforated sheet, 2 mm	A54-40

## Steel wire mesh

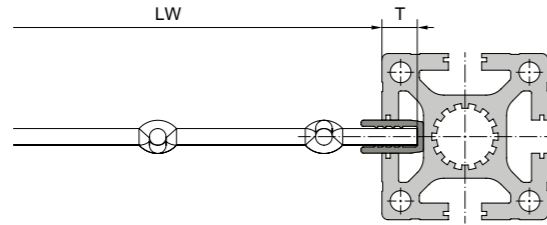

Application with U-Clamping extrusion B19-6

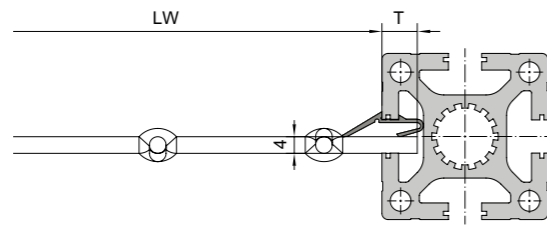

Application with wedge extrusion C39-45

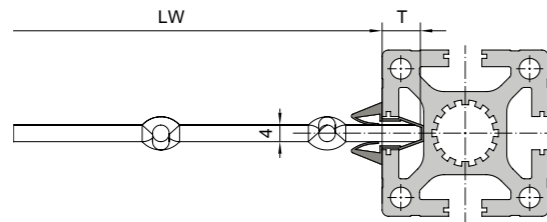

Application with grid extrusion C39-70

### Application

Safety guards, store partitions, restricted access, etc.

This wire mesh can be inserted directly into the 8mm slot on the extrusion together with the surround extrusion C39-70 and the clamping extrusions B19-6.

### Specification

Zinc-coated steel

Mesh width: 40 mm  
 Wire thickness: 4 mm  
 Size: max. 1000 x 2000 mm  
 Weight: 4.5 kg/m<sup>2</sup>

### Measurement data

B19-6	Base 30	Base 40	Base 45	Base 50
Mesh case depth T	5 mm	8 mm	10 mm	12.5 mm
Mesh size A50-44	LW + 10 mm	LW + 16 mm	LW + 20 mm	LW + 25 mm
U-clamp extrusion length in a mitre cut	LW + 13 mm	LW + 19 mm	LW + 22 mm	LW + 28 mm

C39-45	Base 30	Base 40	Base 45	Base 50
Mesh case depth T	-	8.5 mm	11 mm	13 mm
Mesh size A50-44	-	LW + 17 mm	LW + 22 mm	LW + 26 mm

C39-70	Base 30	Base 40	Base 45	Base 50
Mesh case depth T	-	9 mm	9 mm	9 mm
Mesh size A50-44	-	LW + 18 mm	LW + 18 mm	LW + 18 mm
U-edging extrusion length in a mitre cut	-	LW + 20 mm	LW + 20 mm	LW + 20 mm

### Order data

Steel wire mesh      A50-44 AxB

## Channel reducing strips

### Channel reducing strip

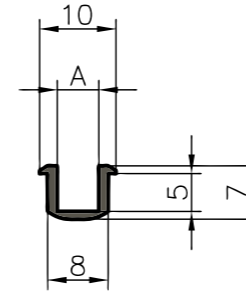

### Application

Channel reducing strips are used if 3, 4 or 5 mm panels are to be inserted into the extrusion slots.

### Specification

Grey PVC for panels of 3, 4 or 5 mm in thickness

Plate insertion depth: 4 mm

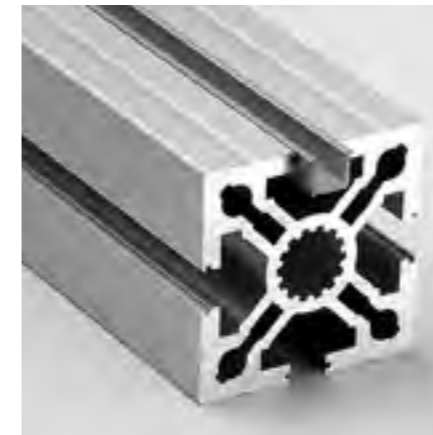

### Order data

Channel reducing strip	Order number
Standard length 5000 mm	A = 3.5 mm A39-33-5M
Cut to length	A39-33-02-02/...
Standard length 5000 mm	A = 4.5 mm A39-32-5M
Cut to length	A39-32-02-02/...
Standard length 5000 mm	A = 5.5 mm A39-34-5M
Cut to length	A39-34-02-02/...

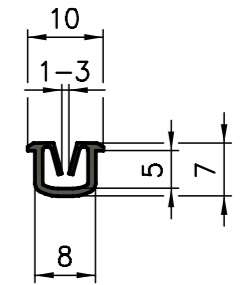

### Application

For thin sheets e.g. expanded metal, steel sheets, etc.

### Specification

Grey PVC for panels up to 3 mm  
 Plate insertion depth: 4 mm

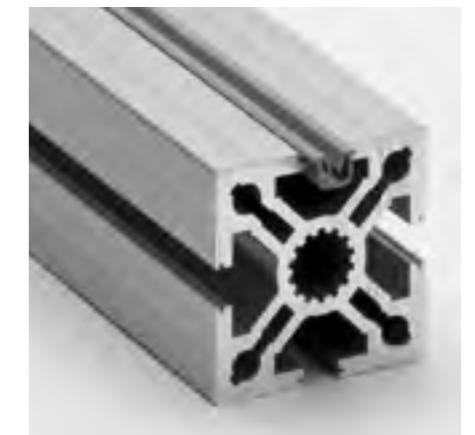

### Order data

Channel reducing strip	Order number
Standard length 5000 mm	A39-31-5M
Cut to length	A39-31-02-02/...



## Insert extrusion PVC Base 30

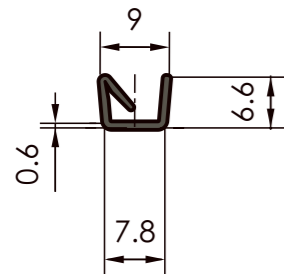

### Application

The inlay extrusion is used when installing panel elements with a thickness of 5 and 6 mm.

### Specification

PVC grey for panel thicknesses: 5 and 6 mm

## PVC filler strips

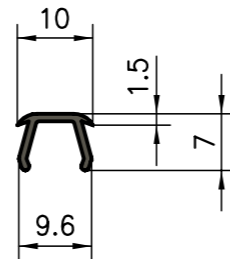

### Application

The PVC filler strip can be clipped into the 8 mm longitudinal slot on any extrusion after assembly and is available in grey or black.

### Specification

Grey or black PVC

## Aluminium filler strip

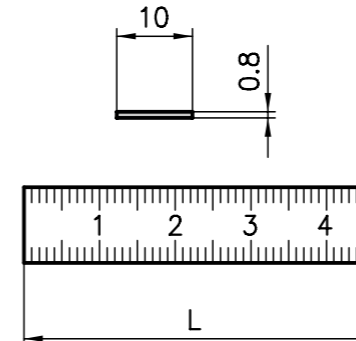

### Application

These aluminium strips can be used to blank off the longitudinal slots on all extrusions with a base of 40, 45 and 50. They are extremely easy to cut to length using tin snips or shears. They can be supplied at short notice in any RAL colour in addition to the standard colours (natural anodised or black powder coated).

### Specification

Aluminium 0.8x 10 anodised or black anodised with millimetre scale

## Aluminium sealing extrusion 50/40/30

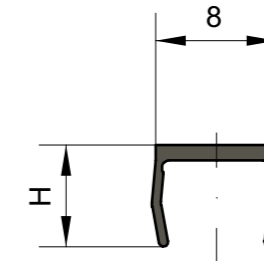

### Application

The grooves of the construction profiles are undoubtedly very practical. With certain constructions, however, they disrupt the appearance and attract dirt. The cover profiles made of aluminium facilitate a closed appearance despite maximum flexibility offered by the open grooves. Dirt can thus no longer be deposited either.

### Specification

Aluminium anodised

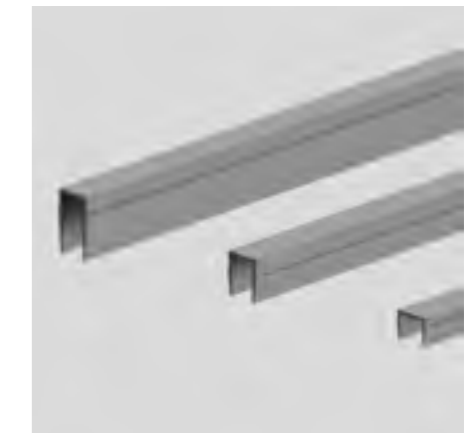
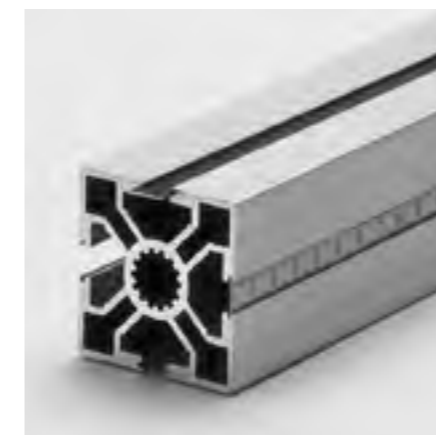
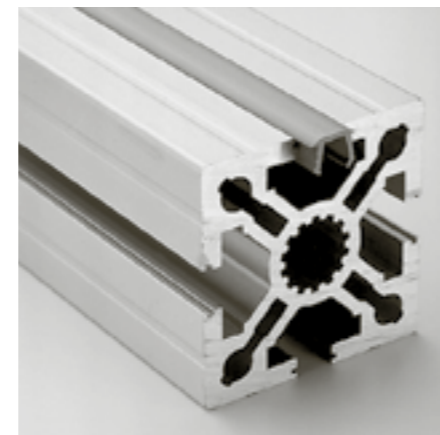

Order data	Order number
Insert extrusion	
Standard length 5000 mm	B39-51-5M
Cut to length	B39-51-02-02/...

Order data	Order number
Filler strips	grey
Standard length 5000mm	A39-25-5M
Cut to length	A39-25-02-02/...
Filler strips	black
Standard length 5000mm	A39-26-5M
Cut to length	A39-26-02-02/...

Order data	Order number
Aluminium filler strip	anodised mm-scale
L = 1000 mm	A39-16
L = 2000 mm	A39-17 A39-18

Measurement data	
Base	H
50	14.5
40	10
30	6.7

Order data	Order number
Aluminium sealing extrusion	Base 50
Standard length 3000 mm	A39-22-3M
Cut to length	A39-22-02-02/...
Aluminium sealing extrusion	Base 40
Standard length 3000 mm	C39-22-3M
Cut to length	C39-22-02-02/...
Aluminium sealing extrusion	Base 30
Standard length 3000 mm	B39-22-3M
Cut to length	B39-22-02-02/...

## Channel reducing strips and filler strips

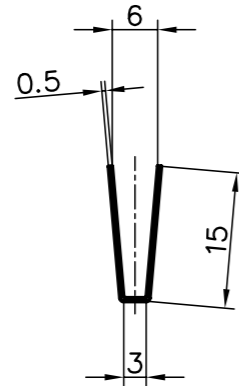
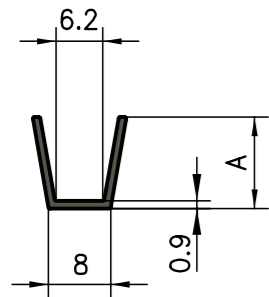

### Application

To hold panels which are 6 mm thickness. They can also be inverted to blank off the slots on triple channel extrusions.

### Specification

Grey PVC

### Application

When fitting 3mm panels for base 40 panels extrusions. (Page 46)

### Specification

Black PVC

## Supporting extrusion

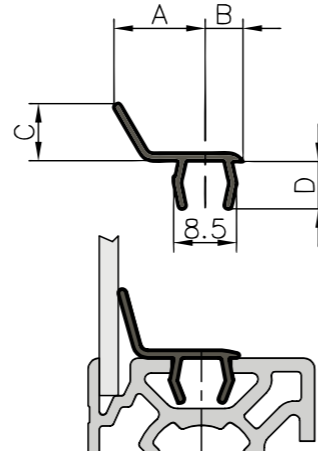

### Application

The supporting extrusion has two functions; it gives optimum support (pressure) to thin panels which are inserted into the narrow slots and at the same time it also covers the extrusion connector slots.

### Specification

Suitable for panel thickness of 2–3 mm  
Grey PVC

### Measurement data

Extrusion base	A	B	C	D
30	13	5	8	6
40	15	7	10	9



### Order data

Order data	Order number
Clamping extrusion 30	B39-25-5M
Standard length 5000 mm	B39-25-02-02/...
Cut to length	

Order data	Order number
Supporting extrusion 40	C39-25-5M
Standard length 5000 mm	C39-25-02-02/...
Cut to length	

## H-strip

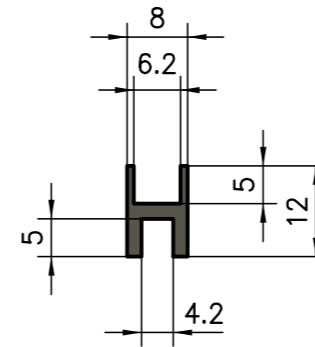

### Application

Used in combination with the B39–55 channel reducing strip, this H-strip allows lift-on or lift-off panels to be inserted or removed.

Bottom: B39–35

Top: B39–55

### Specification

Grey PVC for panels of 4 or 6 mm in thickness

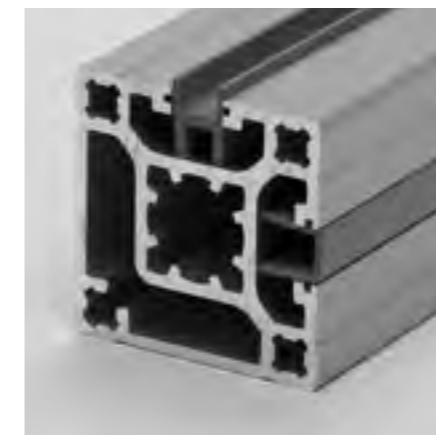

### Order data

Order data	Order number
H-strip	extrusions B05-1
Standard length 5000 mm	B39-35-5M
Cut to length	B39-35-02-02/...

## Wedge extrusion

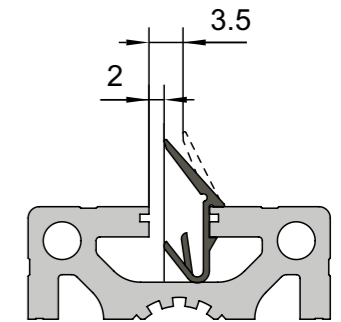

### Application

The wedge extrusion can be pressed into the slot on extrusions with a base of 40, 45 and 50 mm. The force holds the panels tightly in place, however thick they are.

### Specification

Suitable for panel thickness of 2–3.5 mm  
Grey PVC

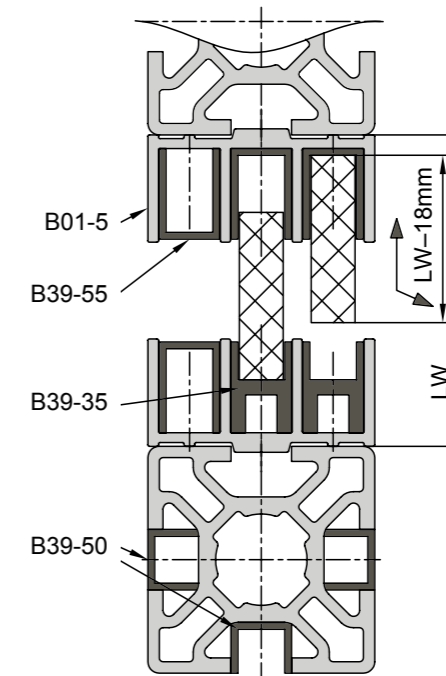

### Order data

Order data	Order number
Wedge extrusion	C39-45-5M
Standard length 5000 mm	C39-45-02-02/...
Cut to length	

### Order data

Order data	Order number
Channel reducing strip	base 50
A = 14.5 mm	
Standard length 5000 mm	A39-50-5M
Cut to length	A39-50-02-02/...
Channel reducing strip	base 40
A = 10 mm	
Standard length 5000 mm	C39-50-5M
Cut to length	C39-50-02-02/...
Channel reducing strip	base 30
A = 6.5 mm	
Standard length 5000 mm	B39-50-5M
Cut to length	B39-50-02-02/...
Channel reducing strip	base 45 / extrusions B05-1
A = 12 mm	
Standard length 5000 mm	B39-55-5M
Cut to length	B39-55-02-02/...

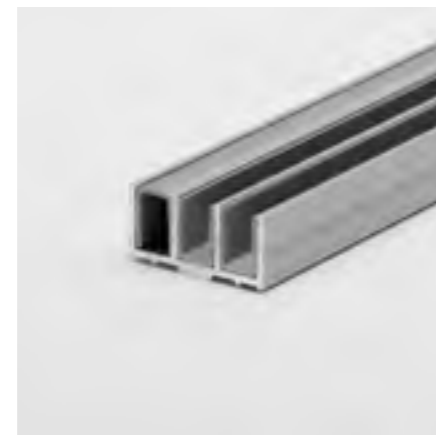

### Order data

Order data	Order number
Channel reducing strip	Base 40
Standard length 5000 mm	C39-64-5M
Cut to length	C39-64-02-02/...

## Door stop profile

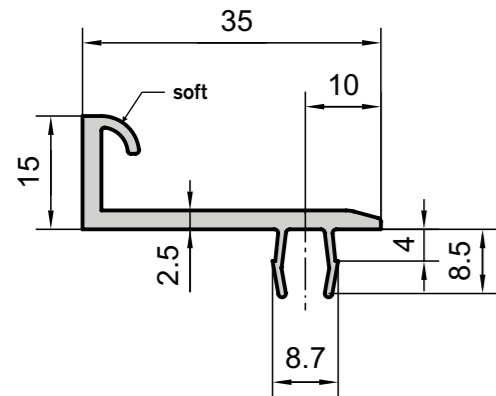

### Application

As the name says, this profile is used as a door stop. The foot geometry means that it can be clipped into the basis 40. The soft sealing lip muffles firstly the closing and facilitates a certain tightness. It should be ensured that the door gap is of a correspondingly large size.

### Specification

Hard (soft) PVC, grey

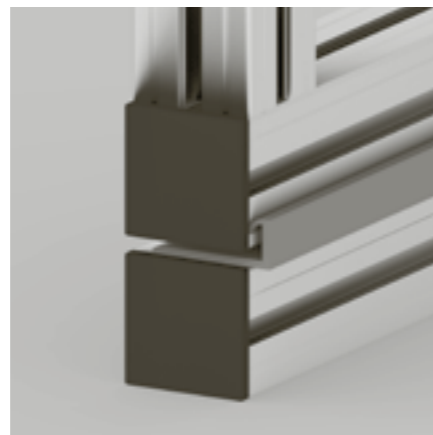

Matching extrusion combinations:

	Frame	Door
Base	40	40
Base	50	45

Order data	Order number
Door stop profile	
Standard length 5000 mm	C39-55-5M
Door stop profile	
Cut to length	C39-55-02-02/...

## Safety-edge extrusion

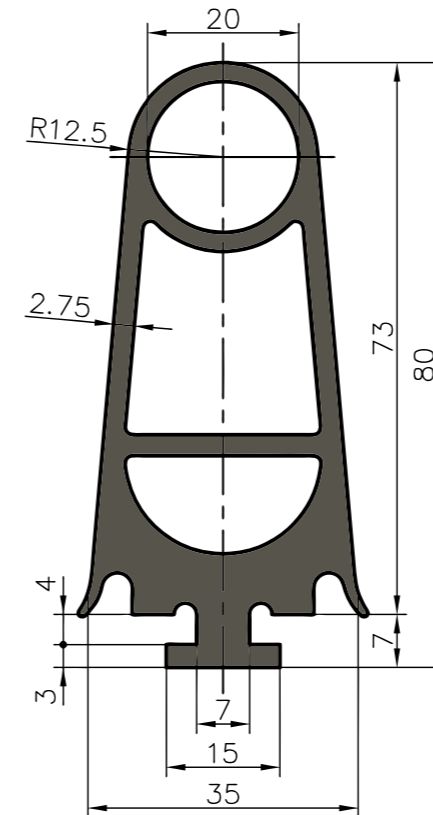

### Application

Mainly used as a personal safety-extrusion on automatic sliding doors and everywhere there is danger of crushing parts. It fits to the respective KANYA-extrusions.

### Specification

EPDM caoutchouc black

Order data	Order number
Safety-edge extrusion	
Standard length 2000 mm	C39-90-2M
Cut to length	C39-90-02-02/...

## Protective edge profile Base 30

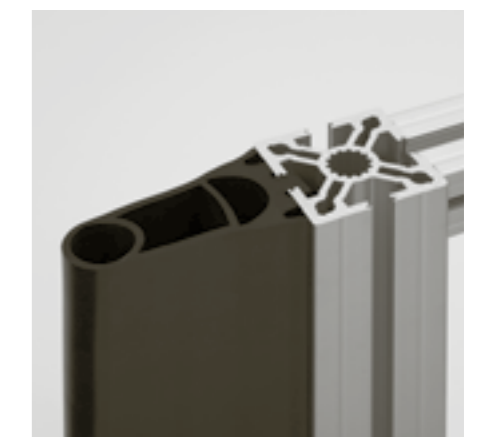
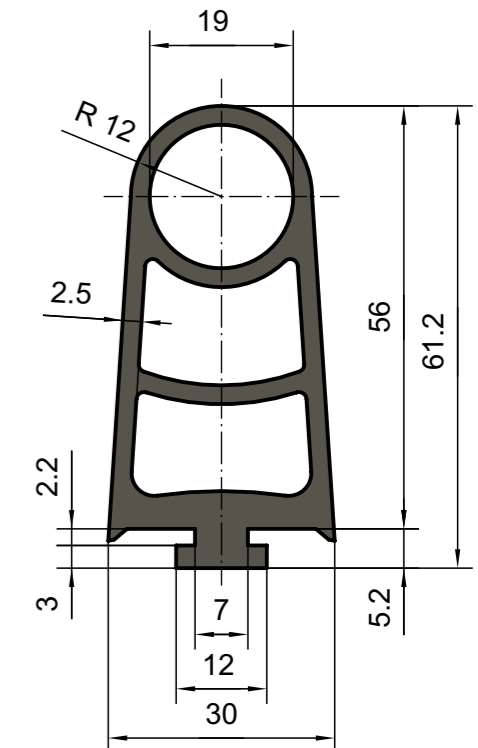

Order data	Order number
Protective edge profile Base 30	
Standard length 1900 mm	B39-90-1.9M
Cut to length	B39-90-02-02/...

### Ribbed rubber extrusion

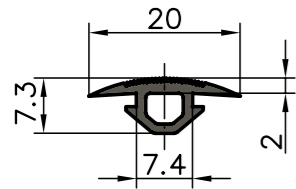

#### Application

The ribbed rubber extrusion can be used to protect the surface of extrusions, as an anti-slip strip or as a seal. This extrusion can be inserted into the slot of nearly all base 50, 45, 40, 30 and 20 cross-sections.

#### Specification

EPDM, black  
Weight: 70g/m

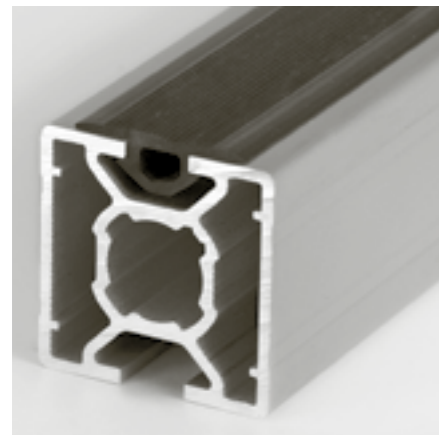

Order data	Order number
------------	--------------

**Ribbed rubber extrusion**  
Standard length of rolls of 100 m D39-86-100M  
Cut to length D39-86-02-02/...

### Semi-circular sealing strip

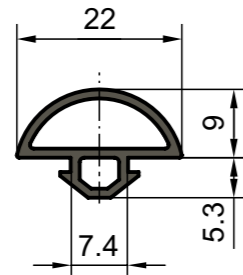

#### Application

The semi-circular sealing strip can be inserted into the slots on almost all cross-sections of the base 50, 45, 40, 30 and 20. It is used as a seal of any kind, mostly also in clean room technology.

#### Specification

Material tpe 65, black

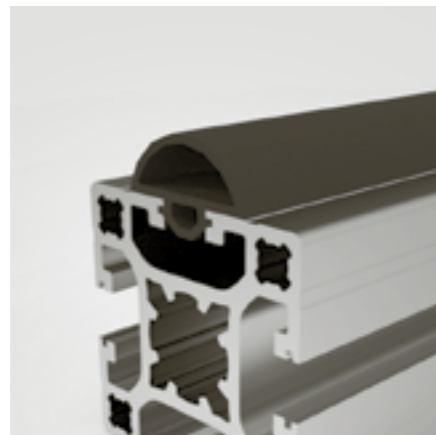

Order data	Order number
------------	--------------

**Semi-circular sealing strip**  
Standard length of rolls of 25 m A39-86-25M  
Cut to length A39-86-02-02/...

### U-sealing strip

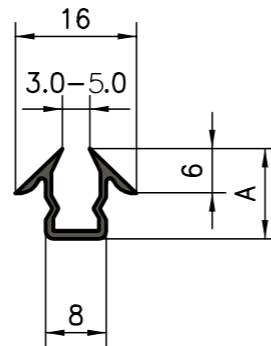

#### Application

This sealing strip can be inserted into the 8 mm slots on any extrusions and is suitable for panels measuring between 3 and 6 mm in thickness.

#### Specification

Black neoprene rubber, oil-resistant.  
Installation depth for panels:  
A = 12: 5 mm  
A = 18: 10 mm

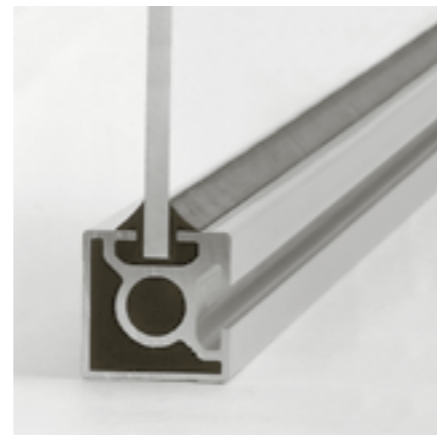

Order data	Order number
------------	--------------

**U-sealing strip, A = 12 mm** 45/40/30 mm base  
Standard length of rolls of 100 m B39-65-100M  
Cut to length B39-65-02-02/...

**U-sealing strip, A = 18 mm** 50/45 mm base  
Standard length of rolls of 25 m A39-65-25M  
Cut to length A39-65-02-02/...

### Inlay profile

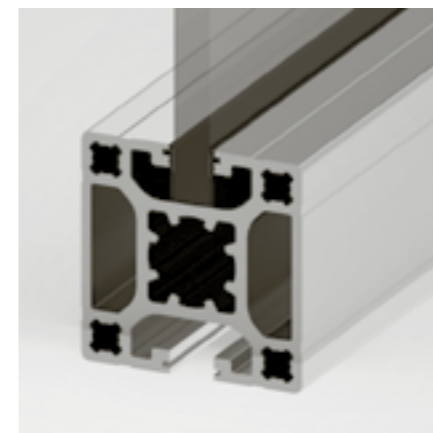
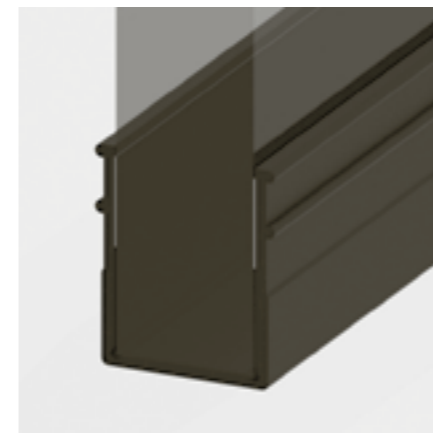
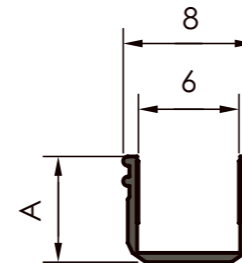

#### Application

For simple glazing (laminated safety glass up to 6.7 mm), the insert profile with adhesive strips for aluminium profiles of base 30, 40 und 50 can be used.

#### Specification

TPE-V

#### Measurement data

	A
A39-56	14.5
C39-56	10
B39-56	6.7

#### Order data Order number

**Inlay profile** 50 base  
Standard length of rolls of 2x 50 m A39-56  
Cut to length A39-56-02-02/...

**Einlageprofil** 40 base  
Standard length of rolls of 2x 50 m C39-56  
Cut to length C39-56-02-02/...

**Einlageprofil** 30 base  
Standard length of rolls of 2x 50 m B39-56  
Cut to length B39-56-02-02/...

### Grid extrusion

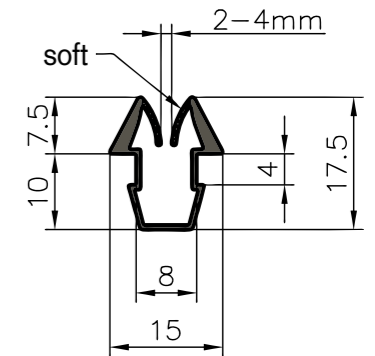

#### Application

Mainly used for holding steel-wire-mesh. The soft lips insulate the vibration and compensates the different thicknesses. It's qualified for panels with 2-4 mm thickness. The grid extrusion fits into the base 50, 45 and 40.

#### Specification

Hard- (soft) PVC, black  
Installation depth for panels: 8 mm

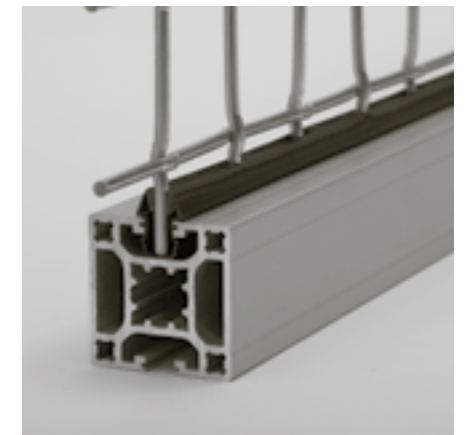

Order data	Order number
------------	--------------

**Grid extrusion**  
Standard length 5000 mm C39-70-5M  
Cut to length C39-70-02-02/...

### Clamping sealing strip Base 30/20

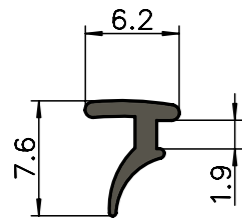

**Application**

This sealing strip is used to stabilise and seal panels in the extrusion cross-sections of base 20 and 30. It is fitted after the panels are inserted.

**Specification**

TPE black, oil-resistant  
For panels 5–6 mm thick

### Clamping rubber seal



**Application**

These profiles are used for the installation of panels in the profile groove. The installation is done after the panels have been inserted. The rubber profiles can simply be pressed into the existing gap. The material automatically results in a damping, sealing and stabilising effect.

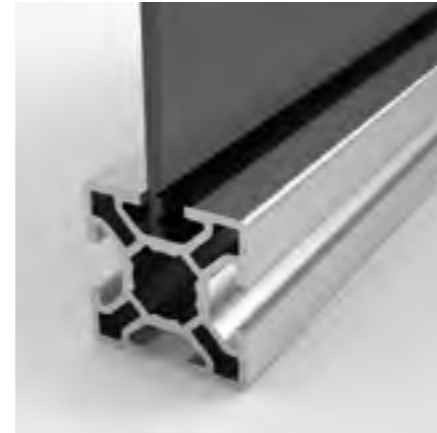

**Specification**

Neoprene rubber black, oil resistant, contains no silicone

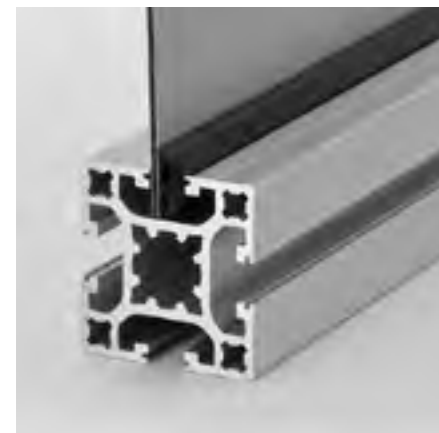
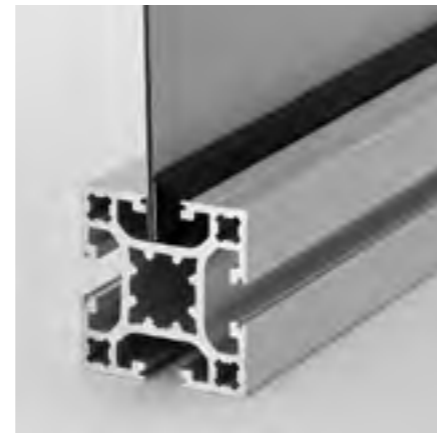

**Measurement data**

Panel thickness	Base 30	Base 40/45/50
1.5 – 2 mm	B39-72	A39-72
3 mm	B39-73	A39-73
4 mm	B39-74	A39-74
5 mm	B39-75	A39-75

**Order data** **Order number**

Base 30		Base 40/45/50	
Panel thickness 1.5 – 2 mm		Panel thickness 1.5 – 2 mm	
Standard length roll: 200 m	B39-72-200M	Standard length roll: 200 m	A39-72-200M
Cut to length	B39-72-02-02/...	Cut to length	A39-72-02-02/...
Panel thickness 3 mm		Panel thickness 3 mm	
Standard length roll: 200 m	B39-73-200M	Standard length roll: 200 m	A39-73-200M
Cut to length	B39-73-02-02/...	Cut to length	A39-73-02-02/...
Panel thickness 4 mm		Panel thickness 4 mm	
Standard length roll: 200 m	B39-74-200M	Standard length roll: 200 m	A39-74-200M
Cut to length	B39-74-02-02/...	Cut to length	A39-74-02-02/...
Panel thickness 5 mm		Panel thickness 5 mm	
Standard length roll: 200 m	B39-75-200M	Standard length roll: 200 m	A39-75-200M
Cut to length	B39-75-02-02/...	Cut to length	A39-75-02-02/...

**Measurement data**

Panels 5–6 mm thick

**Order data** **Order number**

Clamping sealing strip 30/20 base	
Standard length of rolls à 100 m	B39-83-100M
Cut to length	B39-83-02-02/...

### Suspended guard fittings

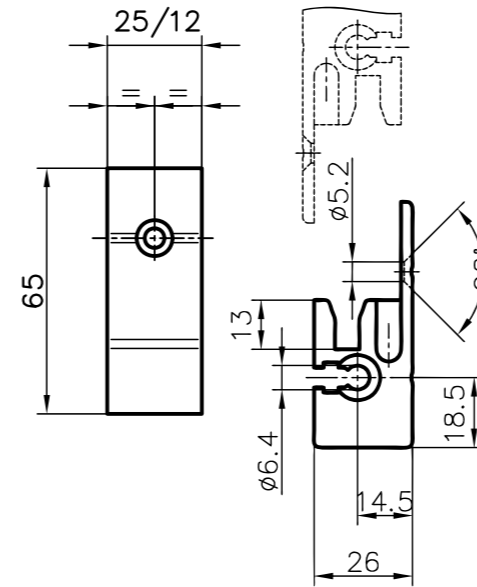

**Application**

For an easy suspension of elements. Extrusion frames with panel-elements can be placed between two extrusions. The vertical and the horizontal suspend position hold the panels in the defined position. The nuts are placed in the slot and with screws it can be fixed from both sides.

**Parts supplied**

2 Suspensions +  
2 Screws with Screw-nuts

**Specification**

Al, anodised in natural colours



**Order data** **Order number**

Suspension small	B=12 mm	B62-20
Suspension large	B=25 mm	B62-25

**Plastic hinges fix**

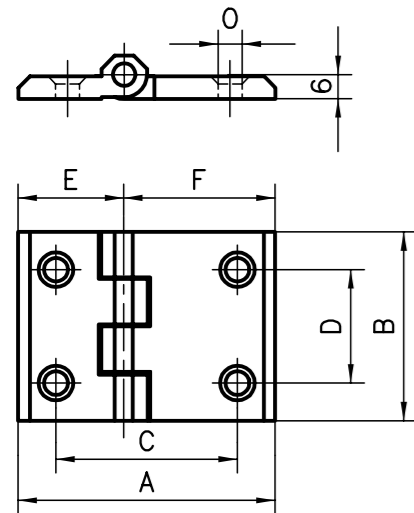

**Application**

That the optimal pivoting characteristics is given for doors, windows ect, the designer needs a selection of hinges, which are fitting exactly.



**Specification**

PA-GF black  
Pin: steel zinc coated

Order data								Order number
Base	A	B	C	D	E	F	O	
50	76	50	56	30	38	38	6.3	A60-00-PA*
45	66	50	48	30	33	33	6.5	E60-00-PA*
50/30	63	50	43	30	25	38	6.3	AB6-00-PA*
30	50	50	30	30	25	25	6.3	B60-00-PA*

\*Item number for fixing kit: add -S to the order number Example A60-60-S

**Plastic hinges lift-off type**

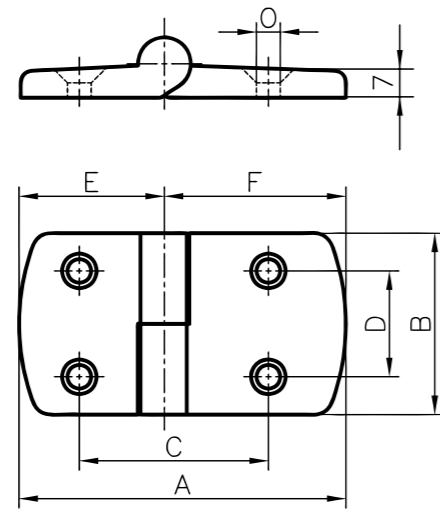

Whether cost efficient plastic, attractive diecasting, or high-strength Aluminium hinges, the assortment gives you the possibility to do the right choice.



**Specification**

PA-GF black  
Pin: steel zinc coated

Order data								Order number
Base	A	B	C	D	E	F	O	
<b>Plastic hinges</b>								
50	96	48	55	28	48	48	6.5	A60-60-PA*
50/40	86	48	50	28	48	38	6.5	AC6-60-PA*
50/30	77	48	45	28	48	29	6.5	AB6-60-PA*
45	87	48	50	28	43.5	43.5	6.6	E60-60-PA*
40	76	48	45	28	38	38	6.5	C60-60-PA*
40/30	67	48	40	28	38	29	6.5	CB6-60-PA*
30	58	48	35	28	29	29	6.5	B60-60-PA*
<b>Aluminium hinges</b>								
50	92	50	54	30	46	46	6.5	A60-60*
50/40	82	50	49	30	46	36	6.5	AC6-60*
50/40	82	50	49	30	36	46	6.5	-
45	72	50	49	30	36	36	6.5	E60-60*
40	72	50	44	30	36	36	6.5	C60-60*

**Aluminium hinges lift-off type**

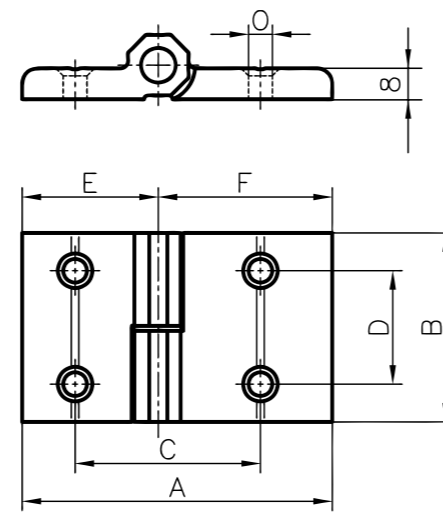

Al anodised natural colours  
Pin: steel zinc coated



**Specification**

Al anodised natural colours  
Pin: steel zinc coated

Order data								Order number
Base	A	B	C	D	E	F	O	
<b>Zn-die casting hinges fixed type</b>								
50	78	50	54	30	39	39	6.3	A60-21*
50/40	73	50	49	30	34	39	6.3	AC6-21**
50/30	67	50	43	30	28	39	6.3	AB6-21*
40	68	50	44	30	34	34	6.3	C60-21*
40/30	62	50	38	30	28	34	6.3	CB6-21*
30	56	50	32	30	28	28	6.3	B60-21*
20	40	40	25	25	20	20	5.3	D60-21*
<b>Al-heavy duty hinges fixed type</b>								
50	92	100	54	75	46	46	6.3	A60-30*
50/40	82	100	49	75	36	46	6.3	AC6-30*
45	72	100	49	75	36	36	6.3	E60-30*
40	72	100	44	75	36	36	6.3	C60-30*

**Zn-die cast hinges fixed type**

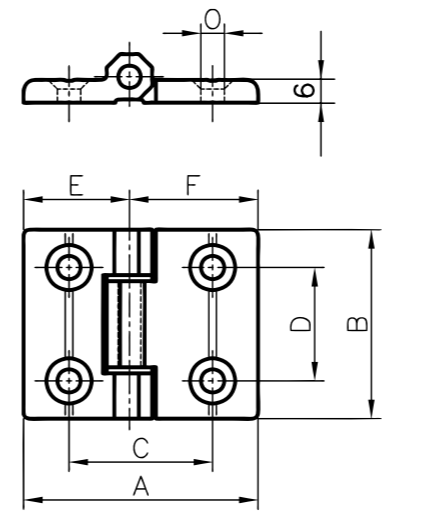

GD-Zn, nickel plated  
(black powder coated on request)  
Pin: steel zinc coated  
washer: PA-6 white

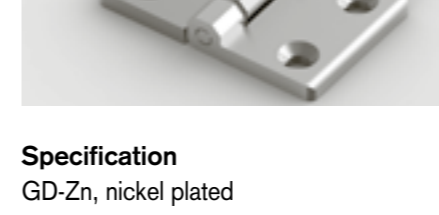

**Specification**

GD-Zn, nickel plated  
(black powder coated on request)  
Pin: steel zinc coated  
washer: PA-6 white

Order data								Order number
Base	A	B	C	D	E	F	O	
<b>Al-heavy duty hinges fixed type</b>								
50	92	100	54	75	46	46	6.3	A60-30*
50/40	82	100	49	75	36	46	6.3	AC6-30*
45	72	100	49	75	36	36	6.3	E60-30*
40	72	100	44	75	36	36	6.3	C60-30*

Order data								Order number
Base	A	B	C	D	E	F	O	
<b>Special hinges lift-off type</b>								
50	92	100	54	75	46	46	6.3	A60-30*
50/40	82	100	49	75	36	46	6.3	AC6-30*
45	72	100	49	75	36	36	6.3	E60-30*
40	72	100	44	75	36	36	6.3	C60-30*

**Al-heavy duty hinges fixed type**

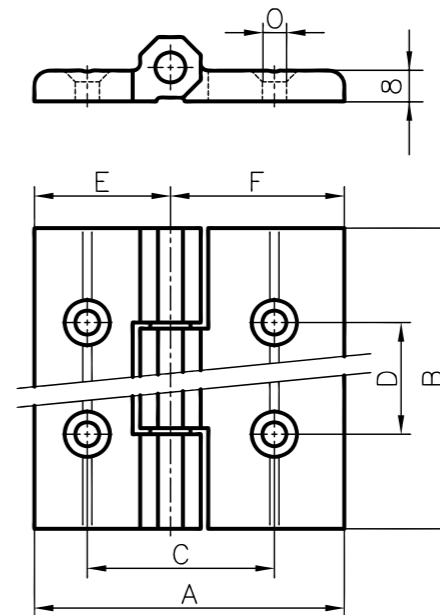

Al, anodised natural colours  
Pin: steel zinc coated  
bush bearing: iglidur G, grey

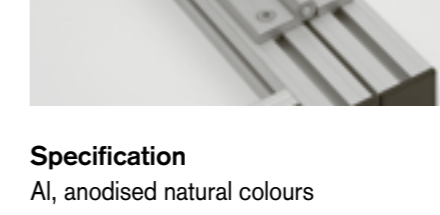

**Specification**

Al, anodised natural colours  
Pin: steel zinc coated  
bush bearing: iglidur G, grey

**Special hinges lift-off type**

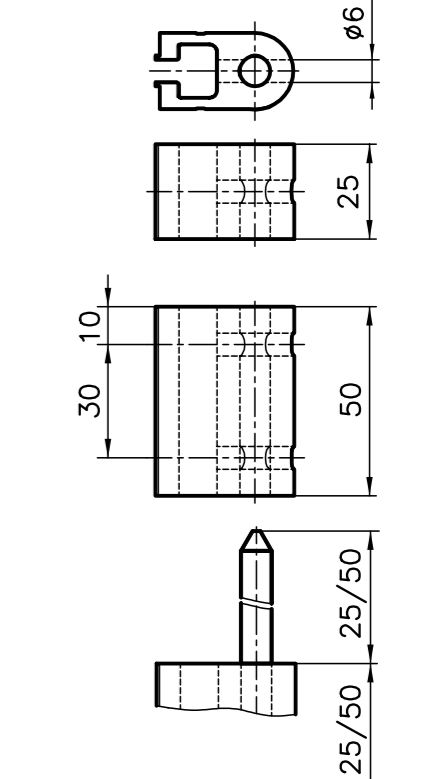

**Specification**

Al anodised natural colours  
Pin Ø 8mm: steel zinc coated

Order data		Order number
Hinge component , no pin	A60-50	A60-55
Hinge component, with a pin	A60-51	A60-56

\* the order number for the fixing kit add -S to the art.no.:  
Example: A60-21-S  
\*\* also applicable for 45x45

### Plastic hinge Base 20 fixed

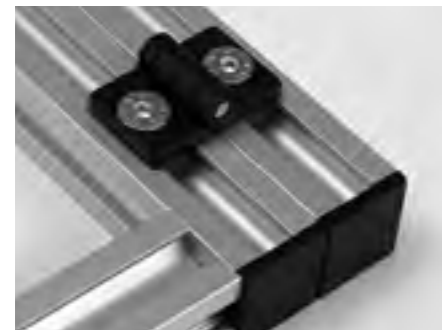
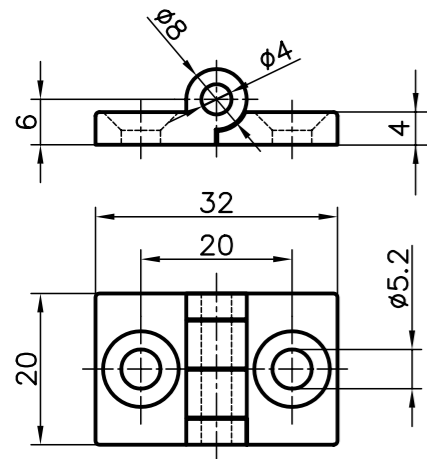

#### Application

For smart work structures which are set up on Base 20, these hinges are a compact solution. With an axial dimension of 20mm, there are no gaps between the extrusions.

#### Specification

PA-GF, black  
Pin: zinc-coated steel

#### Fixing kit\*

Screws and threaded plates

Order data	Order number
------------	--------------

Base 20	D60-00-PA*
---------	------------

\* Item number for fixing kit:  
add -S to the order number  
Example: A60-28-S

### Aluminium flat hinge

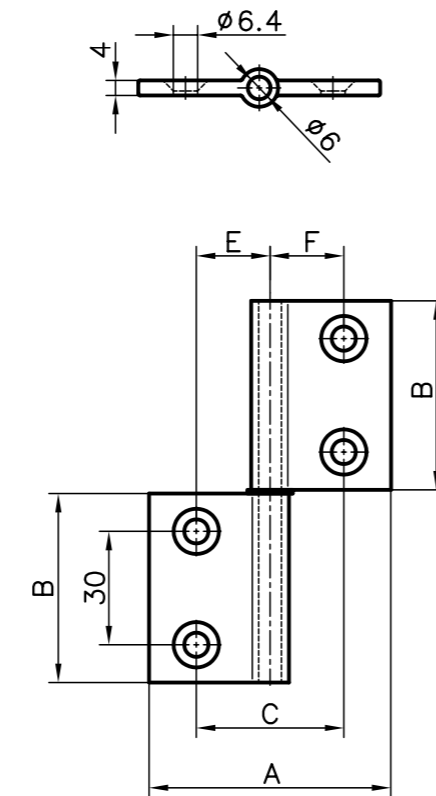

removed. This is important when considering the safety aspects.

#### Specification

Anodised aluminium  
Pin: Stainless steel

Measurement data						Order number
Base	A	B	C	E	F	
50	84	50	60	30	30	A60-29*
45	84	50	55	27.5	27.5	E60-29*
40	84	50	50	25	25	C60-29*
30	64	50	40	20	20	B60-29*
50/45	84	50	57	29.5	27.5	AE6-29*
50/40	84	50	55	30	25	AC6-29*
45/40	84	50	52.5	27.5	25	EC6-29*
45/30	74	50	47.5	27.5	20	EB6-29*
40/30	74	50	45	25	20	CB6-29*
50/30	84	50	50	30	20	AB6-29*

### Aluminium flat hinge

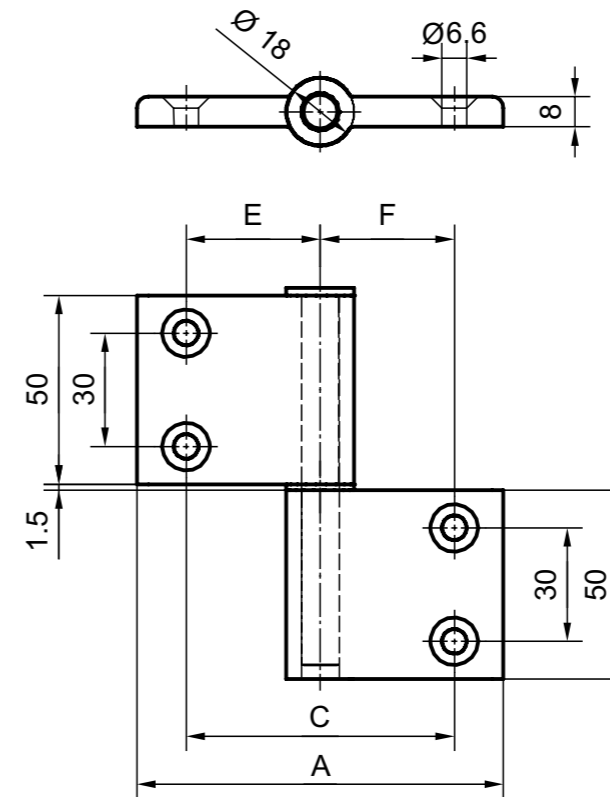

#### Application

The flat band hinges are mounted in a concealed position. When the doors are closed, only the hinge is visible. This provides an attractive design for swing doors. It also has the advantage that when the door is closed, the flat band hinge cannot be removed. This is important when considering the safety aspects.

#### Specification

Anodised aluminium  
Pin: Stainless steel

Measurement data						Order number
Base	A	B	C	E	F	
30/30	77	50	48	24	24	B60-31*
40/40	97	50	58	29	29	C60-31*
45/45	97	50	63	31.5	31.5	E60-31*
50/50	97	50	71	35.5	35.5	A60-31*
30/40	87	50	53	24	29	CB6-31*
30/45	87	50	55.5	24	31.5	EB6-31*
30/50	87	50	59.5	24	35.5	AB6-31*
40/50	97	50	64.5	29	35.5	AC6-31*
40/45	97	50	60.5	29	31.5	EC6-31*
45/50	97	50	67	31.5	35.5	AE6-31*

\* Item number for fixing kit: add -S to the order number Example B60-31-S



### Joint base 40/50

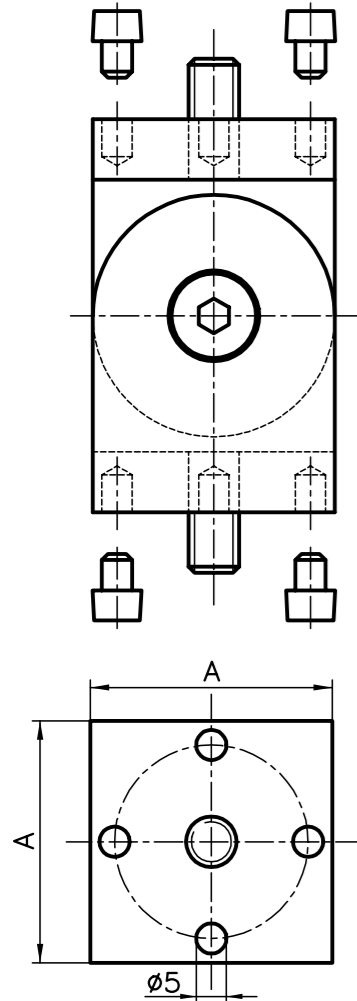

**Specification**  
Aluminium, matt, anodised in natural colours  
Screws and flats: steel zinc coated

**Parts supplied**  
2 assembled joint halves  
4 flats  
1 fixation material S1, S2 or S3 as per situation 1 / 2 / 3

Order data	Order number		
Joint	A	L	
Base 50	50	85	A61-00
Base 40	40	65	C61-00

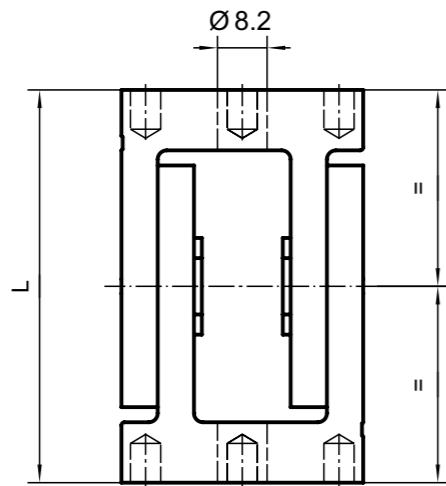

**Application**  
Mainly used to strengthen structures with diagonal braces. It is also suitable to be used as a hinge for swivelling equipment stands, doors, etc. The (5 mm holes are designed to take dowels (which are included). Insert the dowels to give greatest stability.

**Assembly situation**

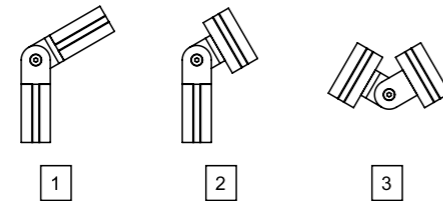

Fixation sets supplement product number with -S1, -S2 or -S3.



### Joints base 40/50 with clamp lever

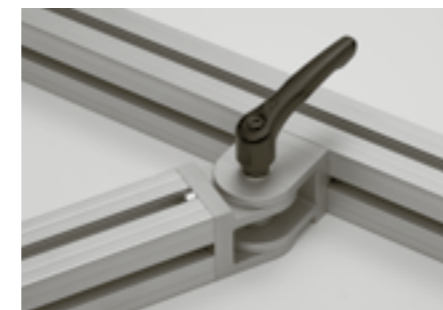
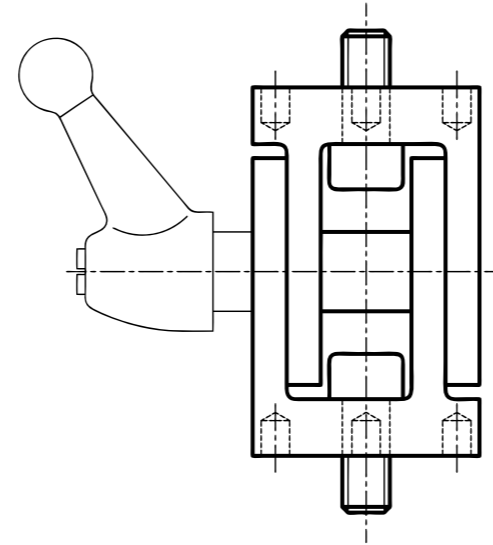

**Specification**  
Aluminium, matt, anodised in natural colours  
Screws and flats: steel zinc coated

**Parts supplied**  
2 assembled joint halves  
4 flats  
1 fixation material S1, S2 or S3 as per situation 1 / 2 / 3

Order data	Order number		
Joint with clamping lever	A	L	
Base 50	50	85	A61-01
Base 40	40	65	C61-01

### Joint base 30

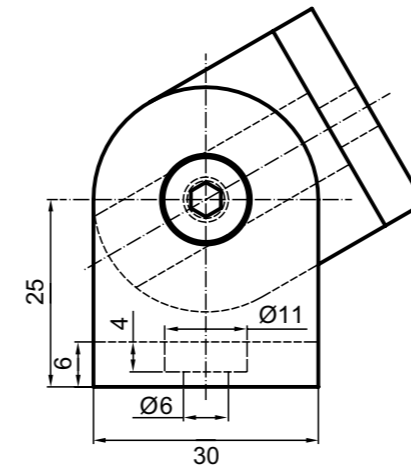

**Application**  
The joints of the basis 30 are fundamentally used as connecting elements in which a connection crosswise to the groove can be generated. At the front, the joint is screwed with a thread insert. The connection laterally to a profile is done with a threaded plate and the matching screw. The variant without clamp lever is clamped when the screw is tightened. The joint is not designed for permanent movement.

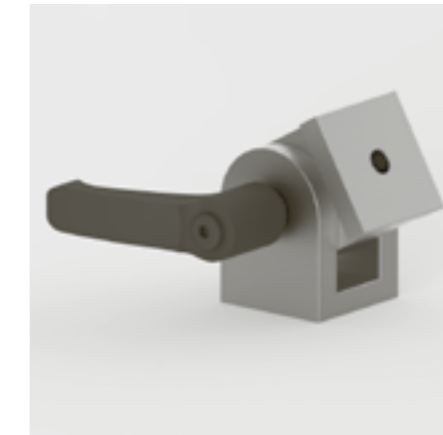

**Specification**  
Aluminium, matted, natural coloured anodised

**Parts supplied**  
2 joint halves loose  
1x fixation material S1, S2 or S3 pursuant to situation 1 / 2 / 3  
1 distance busing  
1 counter sunk screw M6x30

**Assembly situation**

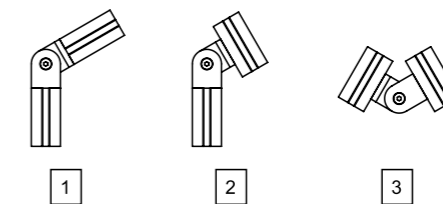

Fixation sets supplement product number with -S1, -S2 or -S3.  
For example: B61-00-S1

Order data	Order number
Joint base 30	B61-00

### Joint base 30 with clamp lever

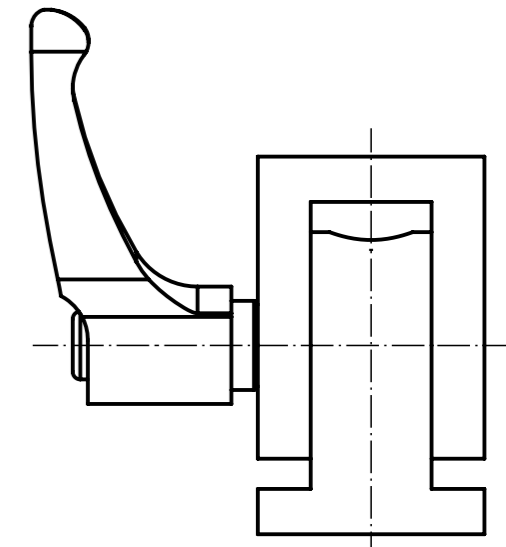

**Application**  
The joint with clamp lever serves to create pivotable constructions easily. It is important here that the joint does not have to absorb strength against the course of the thread as it can otherwise become loose.

**Specification**  
Aluminium, matted, natural coloured anodised

**Parts supplied**  
2 joint halves loose  
1x fixation material pursuant to situation 1 / 2 / 3  
1 clamp lever M6

Order data	Order number
Joint base 30 with clamp lever	B61-01



## Corner pieces



### Attachment

All corner pieces can be mounted using three threaded connectors for the respective extrusion sizes. These can be found on [page 74](#) or simply order a fixing kit. The order number of the fixing kit consists of the respective item number of the corner piece to which -S is added.

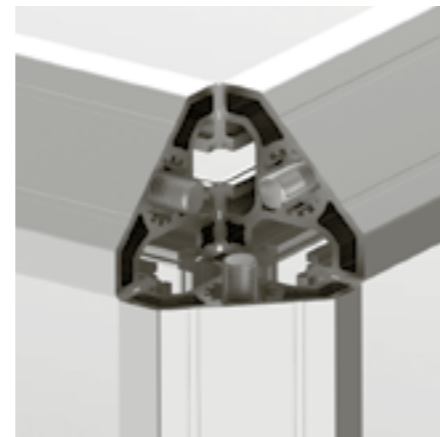

Corner piece fixing kit 3 threaded connectors

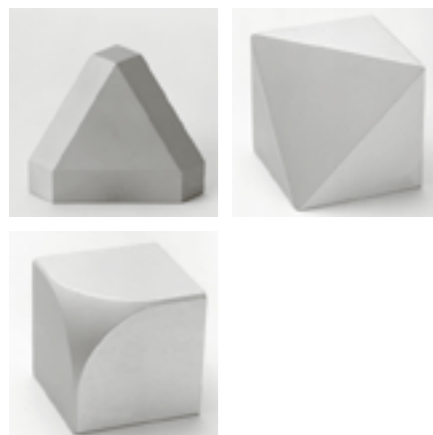

### Application

Gives an attractive finish to the corners of display cases, work benches, office furniture, cabinets and other well designed structures. Available rounded or diagonally cut.

### Fixing kit\*

3 PVS connectors with thread

### Specification

Aluminium, anodised in natural colours  
Attached by a PVS threaded connector

Order data	Order number	
<b>Corner piece</b>	<b>round</b>	<b>flat</b>
Base 50 extrusions	A70-00*	A71-00*
A02-8 extrusion		A71-08*
Base 40 extrusions	C70-00*	C71-00*
C02-8 extrusion		C71-08*
Base 30 extrusions	B70-00*	B71-00*
Base 20 extrusions	D70-00*	D71-00*

\* Fixing kit: add -S to the order number  
Example: A70-00-S

## Handles

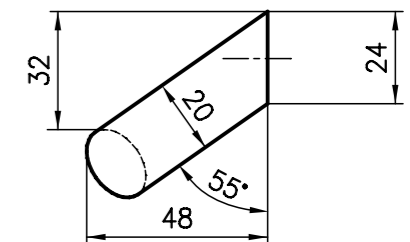
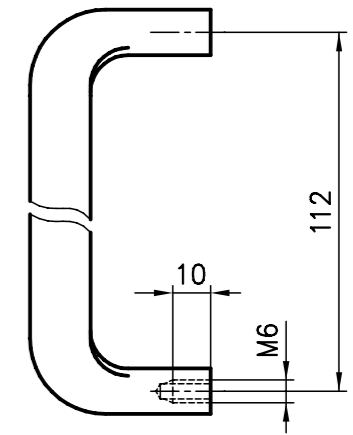
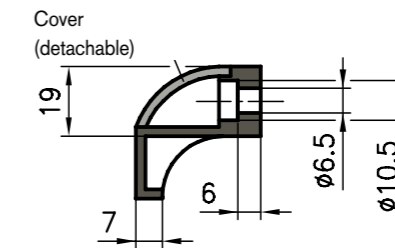
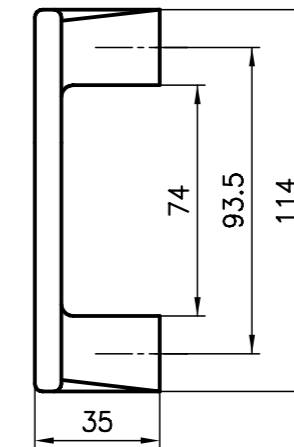
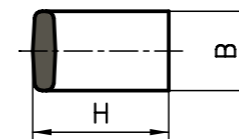
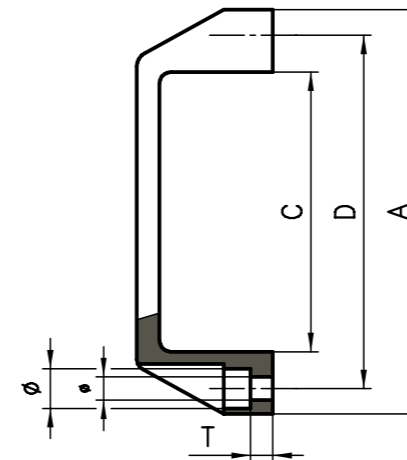

### Application

Highly versatile. Two sizes are available from standard stock. Fixed in place from the inside or outside using M5/8 screws.

### Specification

PA-GF, black

### Measurement data

Handle	A	B	C	D	H	T	Ø	ø
small	107	21	74	93.5	36	6	10.5	6.5
medium	122	19	82	100	33	13	8.5	5.5
large	134	26	95	117	41	6.5	13.5	8.5



Order data	Order number
Small handle	B65-00
Medium handle	B65-01
Large handle	A65-01

### Application

A modern looking, ergonomic handle (mainly used on 20 and 30 base extrusions).

### Specification

PA-GF, black

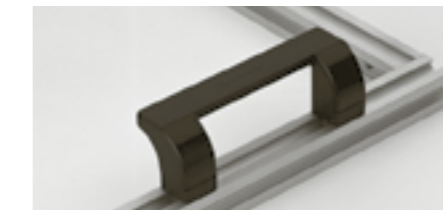

Order data	Order number
Ergo handle	D65-01

### Application

A modern looking, ergonomic handle (mainly used on 20 and 30 base extrusions).

### Specification

Aluminium black RAL 9005 (plastic coated)  
Aluminium natural colour anodised



Order data	Order number	
Handle	black	anodised
	A65-05	A65-06

### Tube handle offset

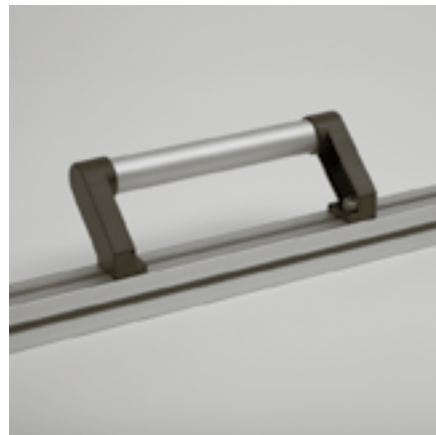
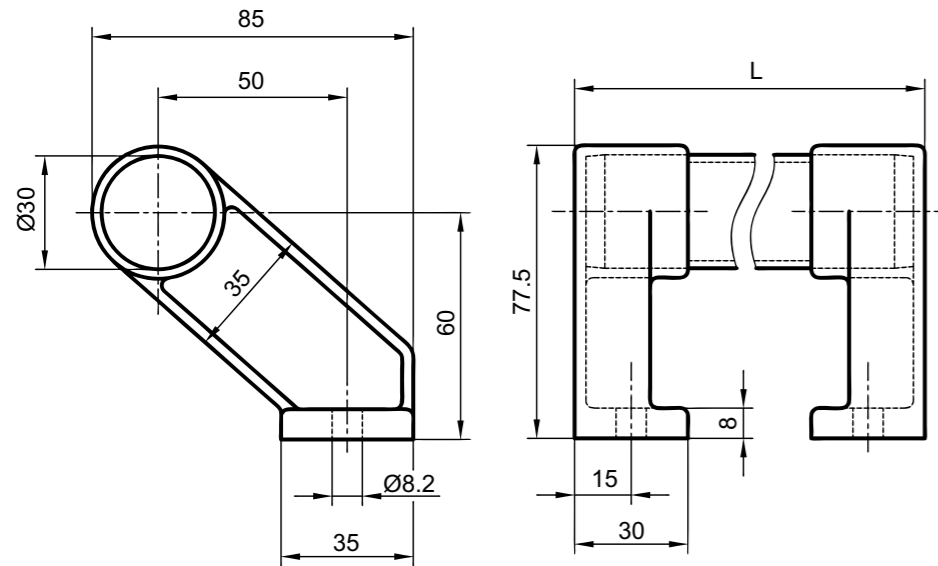

**Application**

These strong tubing grasps are suitable for heavy sliding doors, large windows or also as impact handles for trolleys.

With double sliding doors and critical space conditions, anywhere that risk of trapping hands exists, the offset tubing grasp is highly recommended.

**Specification**

Support: PA-GF, black  
Tube: Al, anodised

Order data	Order number	
	L	
Tube handle offset	250mm	A65-22
Tube handle offset	300mm	A65-23
Tube handle offset	400mm	A65-24
Tube handle offset	500mm	A65-25

Other length available as per request.



### Tube handle straight

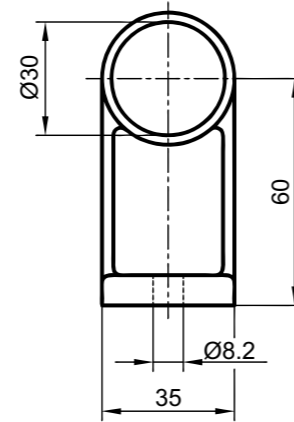

**Specification**

Support: PA-GF, black  
Tube: Al, anodised

Order data	Order number	
	L	
Tube handle straight	250mm	A65-12
Tube handle straight	300mm	A65-13
Tube handle straight	400mm	A65-14
Tube handle straight	500mm	A65-15

Other length available as per request.

### Recessed grip

### Recessed grip

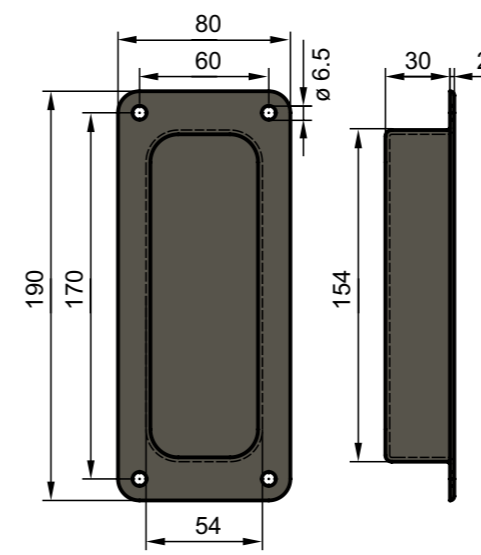

**Application**

A recessed grip made of plastic that is sufficiently large for a hand wearing a glove to be inserted. Or you use this as a storage recess for small parts. Simple fixation by means of screws/rivets.

**Specification**

PA-GF black mat and grey

Order data	Order number
Recessed grip	A65-50

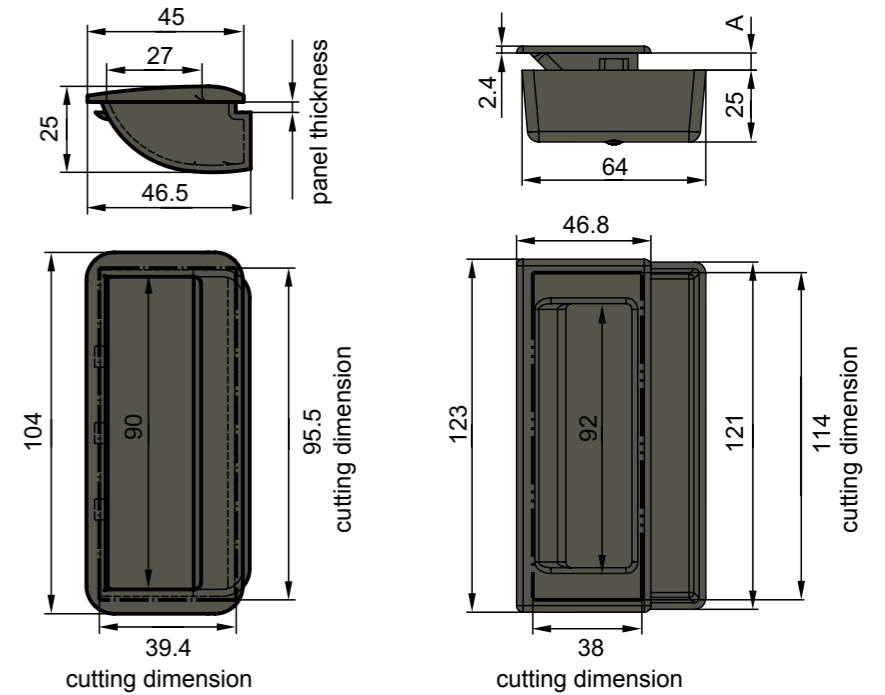

Order data	Order number			
Thickness:	2mm	3mm	4mm	5mm
Grip recess, black	A65-32	A65-33	A65-34	A65-35
Grip recess, light-grey	A65-42	A65-43	A65-44	A65-45

**Recessed grip with clip function**

These recessed grip are suitable for sliding doors as well as for light swing doors. With the clip function, installation is very easy.

**Specification**

ABS plastics

**Recessed grip screwable**

This recessed grip is suitable for sliding or swing doors. The fingers find enough space in the bowl for a good grip. For transparent panel elements, we recommend the retractable recessed grip.

**Specification**

ABS plastics

**Fixing kit**

- 1x front side
- 1x finger protection (back side)
- 2x lenshead, screws ø3x18, galvanized steel

Thickness A: 0.5 – 5mm  
Colour: black



Order data	Order number
Recessed grip, screwable	A65-55

### Ball catches

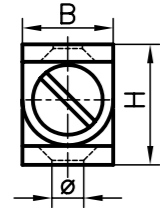
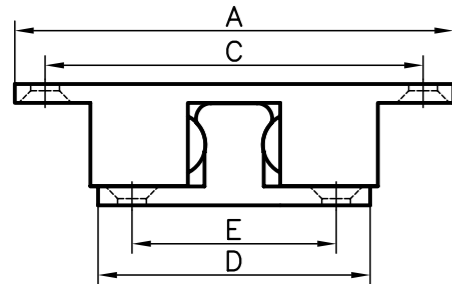

**Measurement data**

A	B	C	D	E	H	ø
<b>Small ball catch</b>						
60	11	50	37	28	15	4.5
<b>Large ball catch</b>						
70	13	57	41	30	17	4.5

**Application**

The handle strip is used as drawer handle. It's also possible to use it for doors and windows.

**Specification**

Nickel-plated brass (ball + spring: steel)  
Clamping force adjustable

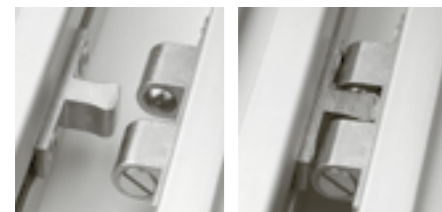

Order data	Order number
Small ball catch	A66-01
Large ball catch	A66-02

### Magnetic fasteners DUO

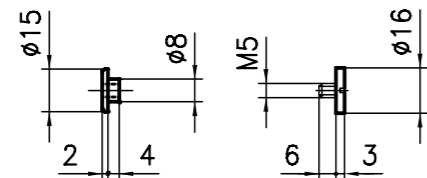
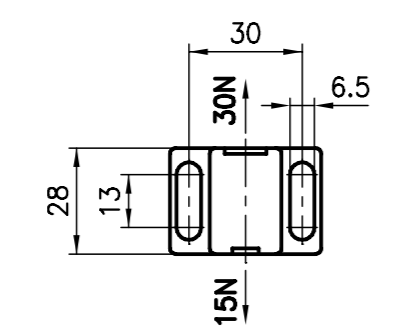
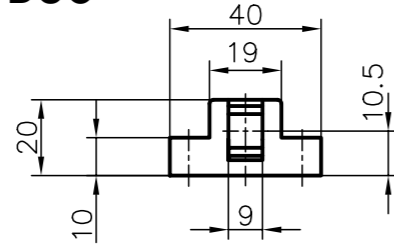

**Application**

This magnetic catch is highly adaptable. You can choose between two retention forces, depending on your requirements. The elongated holes also permit a large adjustment range.

**Specification**

Black plastic with a permanent magnet / pan-head screw with nut.



Order data	Order number
Magnetic fasteners DUO	A67-20

### Mounting bracket magnet DUO

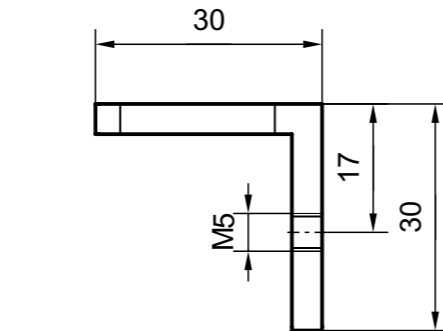
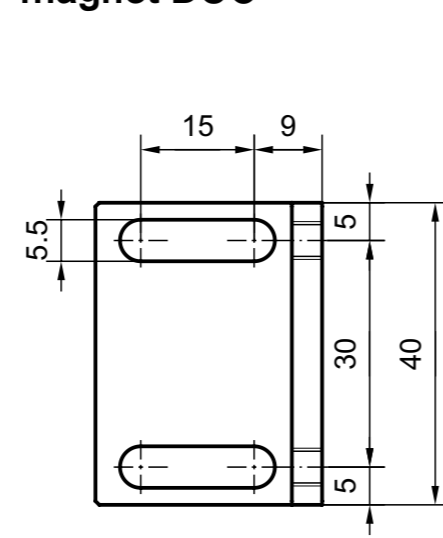

**Application**

This bracket allows the installation of the magnetic lock Duo. With the slit you can adjust the final position.



Order data	Order number
Mounting bracket magnet DUO	A67-21

### Ball catches

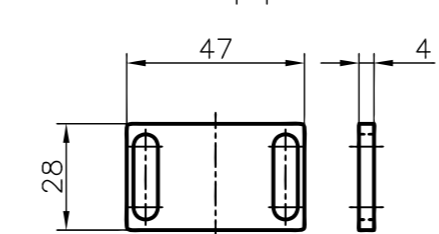
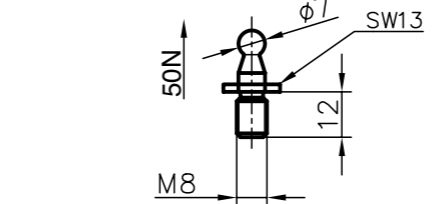
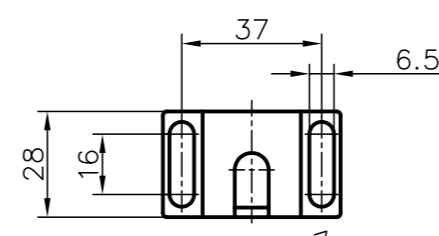
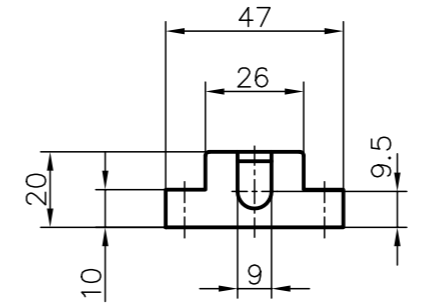

Spacer

**Specification**

PA-GF, black  
fixing screw: steel zinc coated



Order data	Order number
Ball catches	A66-50
Spacer	A66-54

### Mounting bracket ball catch

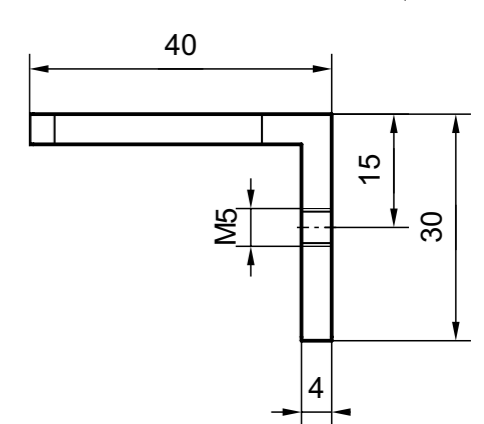
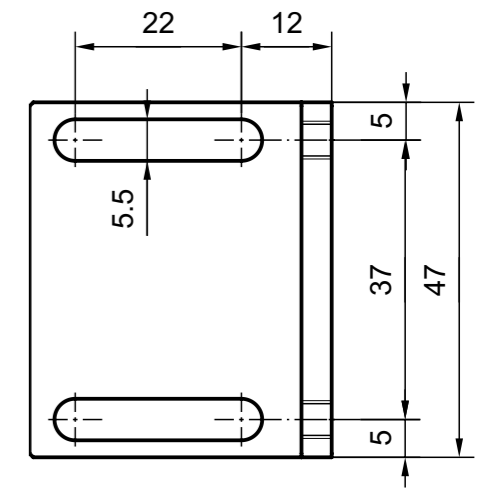

**Application**

This bracket allows the attachment of the ball catch. You can adjust the final position with the the slot.



Order data	Order number
Mounting bracket ball catch	A67-51

### Lug

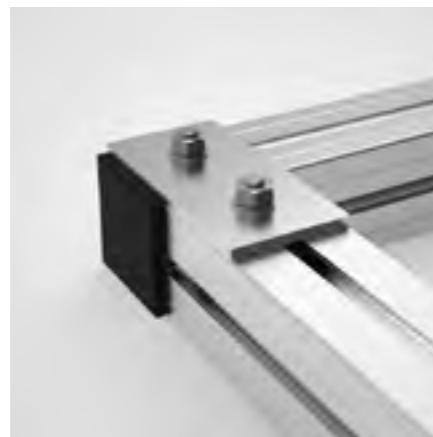
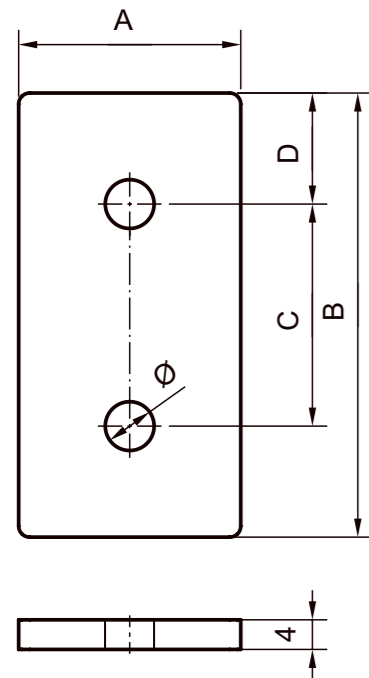

#### Application

The lugs in the basic dimensions 30x60, 40x80 and 50x100 can be used universally and offer many application possibilities.

#### Specification

Al, anodised in natural colour



### Arrester plate

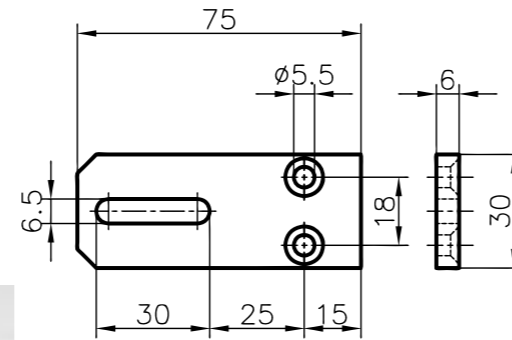

#### Application

As door- or window arresters with fixing possibility. It is possible to screw the arrester plate through the slot and make it secure. It's also qualified as a simple connecting element.

#### Specification

Al, anodised in natural colour

Order data	Order number
Arrester plate	C62-10

### Handle strip

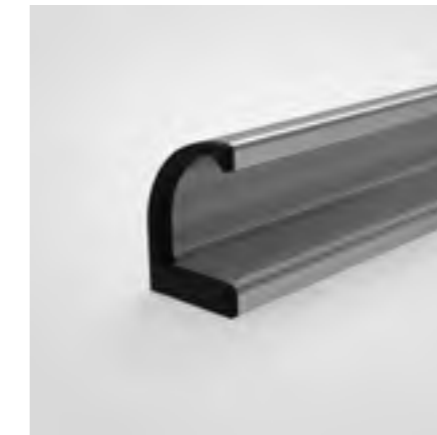
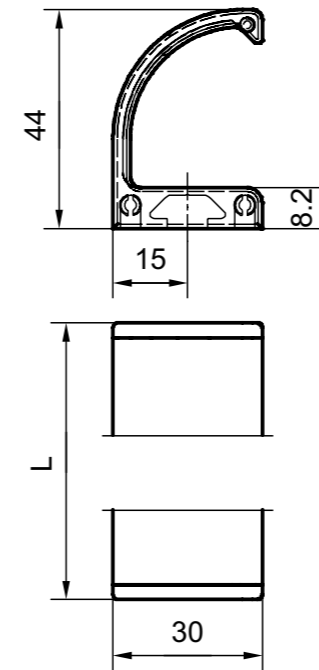

#### Application

The handle strip is used as drawer handle. It's also possible to use it for doors and windows

#### Specification

Al, anodised in natural colour

#### Parts supplied

incl. 2 end cap

Order data	Order number
Handle strip 200 mm*	B65-62
Handle strip 300 mm*	B65-63
Handle strip 400 mm*	B65-64

\*incl. end cap

L = 200 mm incl. end cap

Other length available as per request.

### Quick-release fasteners

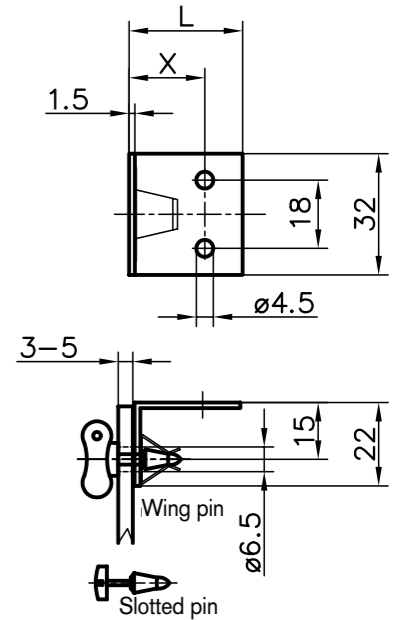

#### Application

For the quick fitting and removal of paneling. Simply press the wing or slotted pin in with your thumb; a quarter turn releases it.

#### Specification

Brackets and bolts: stainless steel  
Spacer ring: rubber

Order data	Order number	Order number	Order number
	L = 18	L = 24	L = 30
	X = 8.5	X = 15	X = 18.5

Quick-release fastener with a wing pin	A64-10	A64-12	A64-11
Quick-release fastener with a slotted pin	A64-20	A64-22	A64-21

#### Measurement data

	A	B	C	D	Ø
Base 30	30	60	30	15	6.6
Base 40	40	80	40	20	9
Base 50	50	100	50	25	9

#### Order data

Order data	Order number
Lug 30x60	B62-30
Lug 40x80	C62-30
Lug 50x100	A62-30

## Rod lock



### Application

The rod lock is installed inside 50, 45, 40 and 30 mm base extrusions. The extrusions have to be milled in the area of the handle. It has a double rod locking mechanism. The rod is cut to the appropriate installation length.

### Specification

Handle: grey (RAL 7015)  
Rod: zinc-coated steel

max. length per rod:  
base 50/45/40 max. 1500mm  
base 30 max. 1100mm

### Parts supplied

- 1 handle with 2 rod adapters
- 2 rods
- 2 plain bearing bushes
- 2 guide bushings
- 2 countersunk screws M5 and 2 threaded plates

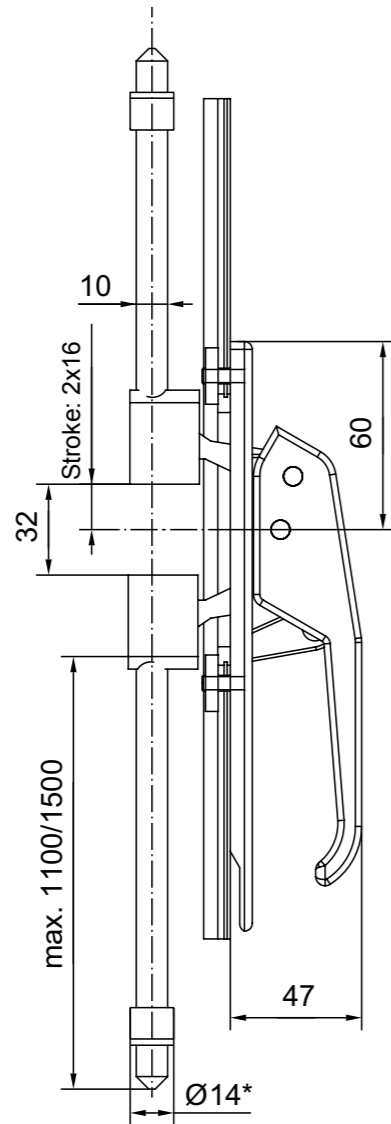

\* Base 30: Ø12

Order data	Order number			
<b>Rod bolt unlockable</b>				
Base	50	45	40	30
	A68-07	E68-07	C68-07	B68-07
<b>Rod bolt lockable</b>				
Base	50	45	40	30
	A68-08	E68-08	C68-08	B68-08

## Inset lock

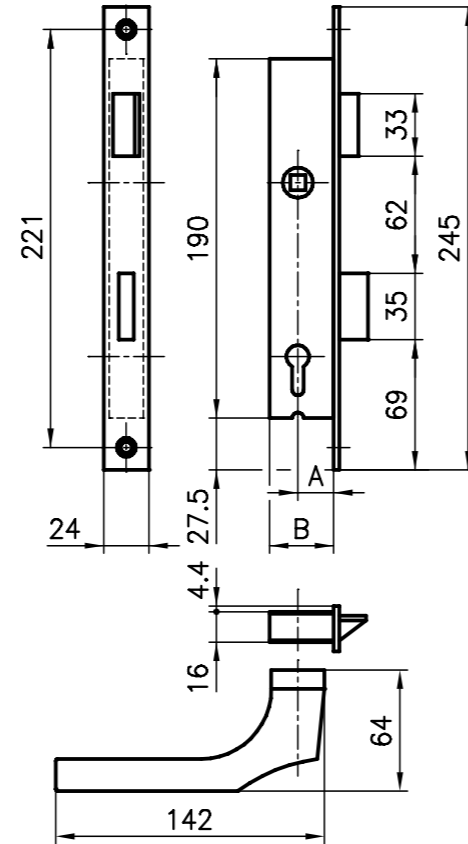

### Application

Lockable and built into the extrusions Base 50, 40 and 30. The extrusion must be milled.

### Specification and parts supplied

Lock: zinc-coated steel  
Cylinder: Nickel plated brass  
Key: Nickel plated steel (3supplied)  
Handle and escutcheon: Al anodised

### Fixing kit\*

Screws and threaded plates

Order data	Order number		
<b>Inset lock</b>			
	A	B	
Extrusion Base	50	27	42
	A68-00*		
Extrusion Base	40	19	34
	C68-00*		
Extrusion Base	30	15	30
	B68-00*		

\* Fixing kit: add -S to the order number  
Example: A68-00-S

## Snap-lock

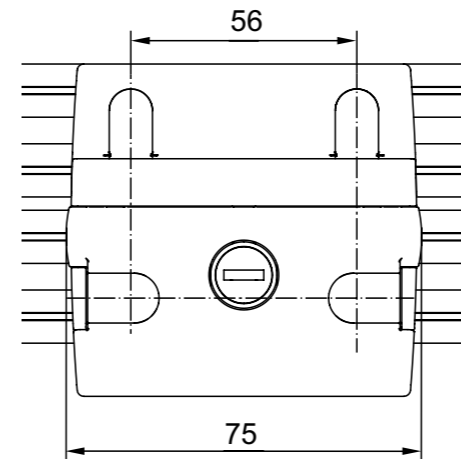

### Application

The snap-lock comprises a door housing with a latch as well as a framework housing. Its versatile design allows the lock to be used for different widths of extrusion. Another advantage is that it is very easy to open and close.

### Specification

GD-Zn, black  
instant locking, 2 keys



Order data	Order number
Snap-lock	A68-51

## Safety switches

### Application

Safety switches are mandatory in many applications. If required by the customer, we will provide and set up the mechanical assembly. Simply send us the switch and we will integrate it in the structure.

Depending on the potential risk, the switches must fulfill various functions, e.g.:

- mechanical locking without power
- signal when door closed
- enabling/disabling of automatic processes

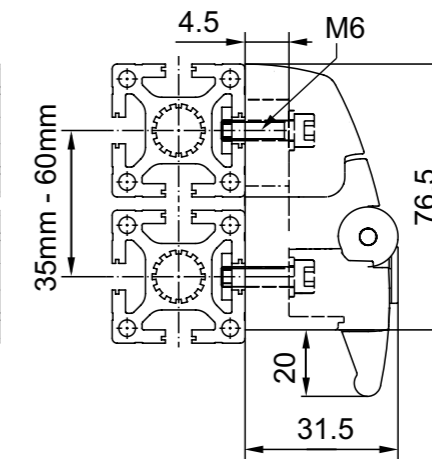

## Locking handle

### Application

Lockable machine doors, such as switch cabinets, service doors or easy access points, are often made with the industry standard locking handle. We also integrate these into our designs.



### Sealing plates

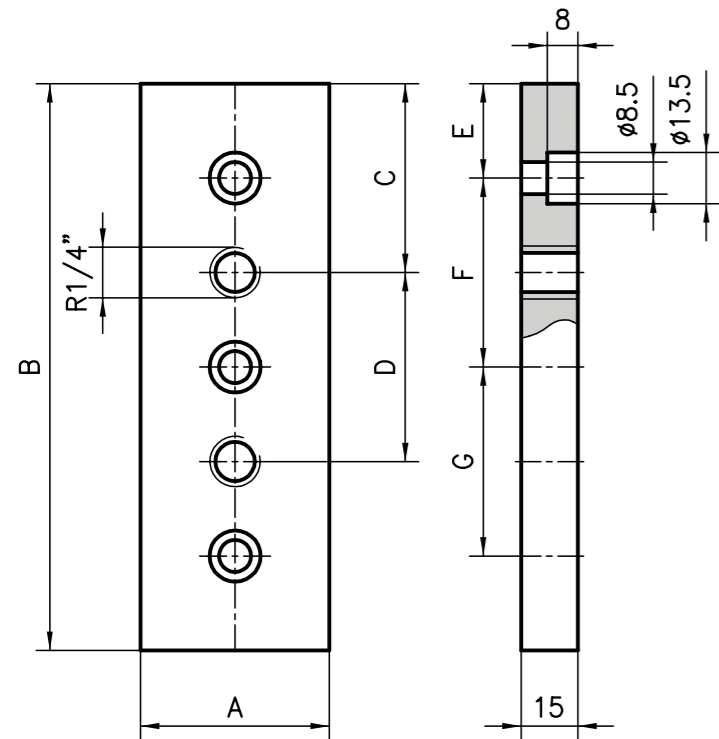

**Application**  
To seal the cut ends of manifold extrusions. Air, water, oil or other media can be supplied or drained off with the appropriate gas fittings.



**Fixing kit\***  
Screws + threaded inserts

**Specification**  
Al, anodised in natural colours  
1/4" gas connection

Order data	Order number							
Sealing plates	A	B	C	D	E	F	G	
40x80 extrusion	40	80	40	-	20	40	-	C80-30*
50x100 extrusion	50	100	50	-	25	50	-	A80-10*
50x150 extrusion	50	150	50	50	25	50	50	A80-30*

\* Fixing kit: add -S to the order number  
Example: C80-30-S

### Flat sealing element

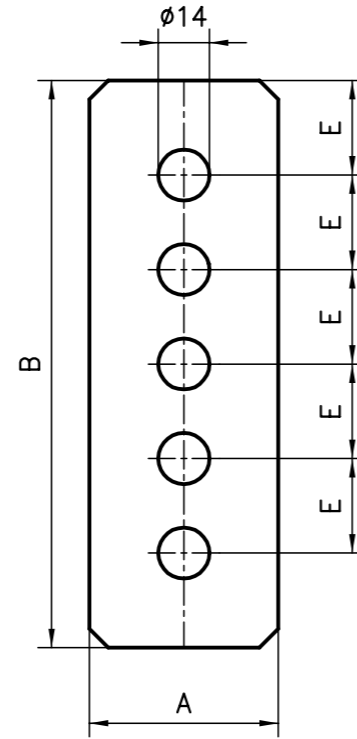

Order data	Order number
Flat sealing element for the sealing plate	
Profil 40x80	C80-31*
Profil 50x100	A80-11
Profil 50x150	A80-31

\*only with base extrusion C01-3

### Steel shafts

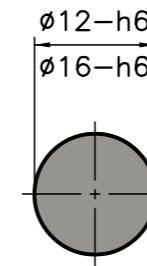

**Application**  
The steel shafts are used in combination with the linear sliding block and the shaft clamping blocks assembled on the appropriate extrusion framework. This serves to create high load-bearing linear guides.

**Specification**  
Steel, Cf 53, hardened, ground  
Hardness: HRc 62 ± 2  
Ø 12 0.9 Kg/m  
Ø 16 1.5 Kg/m



Order data	Order number
Steel shaft ø12	
Standard length 6000 mm	L12-20-6M
Cut to length	L12-20-02-02/...
Steel shaft ø16	
Standard length 6000 mm	L16-20-6M
Cut to length	L16-20-02-02/...

### Shaft clamping block

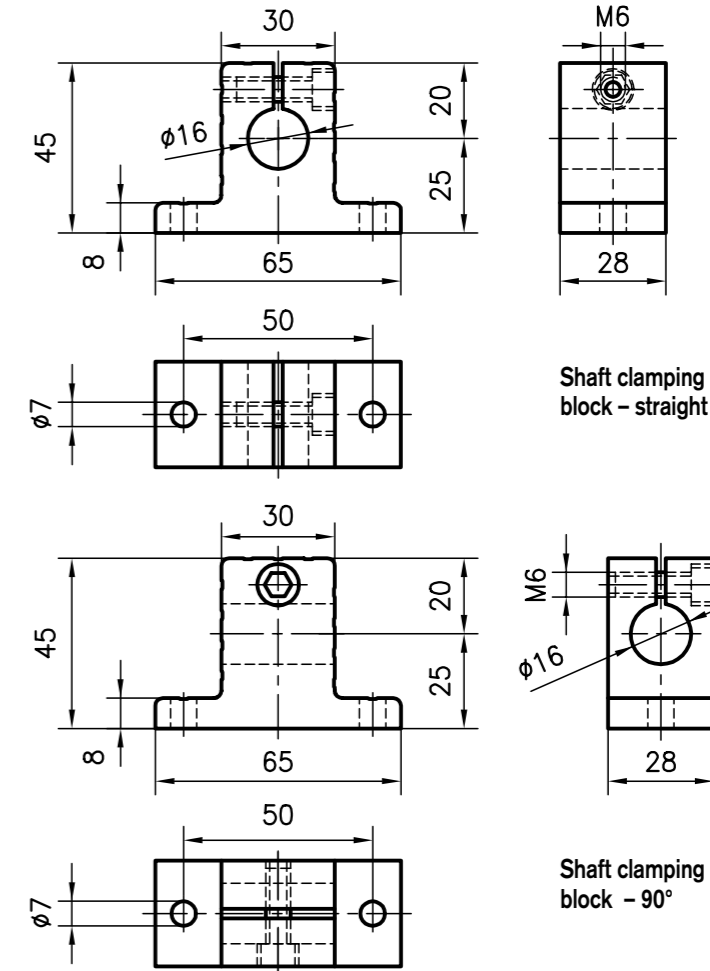

**Application**  
A high-precision linear bearing system can be created very easily with the components, i.e. the shaft clamping block, the linear bearing block and the steel shaft. As there are two different shaft clamping blocks, the system can be assembled flexibly. The fixing centres combine well with the PVS® extrusions.

**Specification**  
Aluminium, anodised in natural colours  
Scope of delivery including screws.



Order data	Order number
Shaft clamping block - straight	L16-60
Shaft clamping block - 90°	L16-65

### Linear sliding block

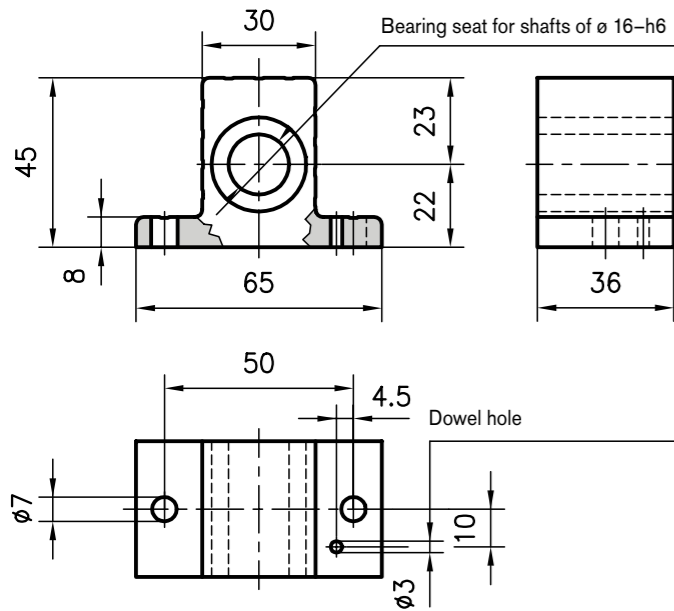

#### Specification

Housing: aluminium, anodised in natural colours

Linear bearing: steel, sealed on both sides, maintenance-free

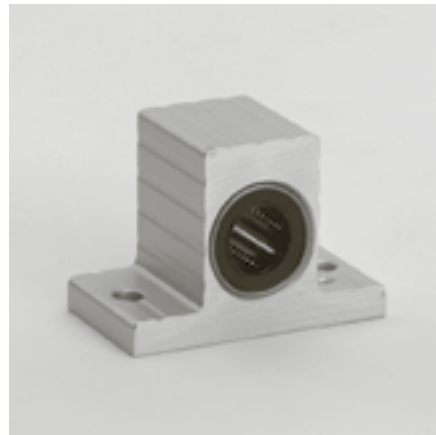

#### Application

The guide extrusion 40x100 is used for high load linear slides. Because of the steel shaft support on one side, the distance between the guides can be freely selected. The shaft is pressed into the designated slot. A stop can be attached to

### Shaft support extrusion 40x100 Type L16-10

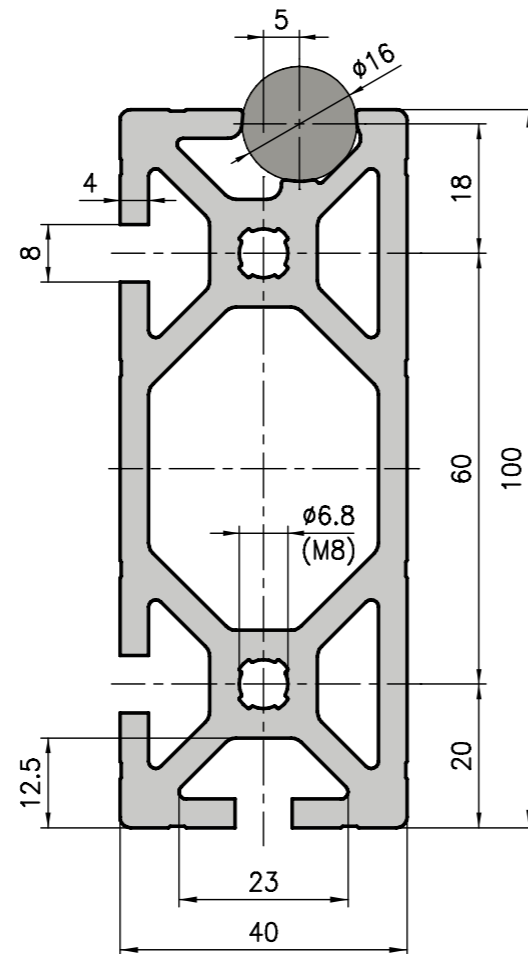

the front face in the holes  $\varnothing 6.8$  with a M8 thread.

The side plates or side construction must be specially designed for this guide, therefore they are only available on request.

#### Order data Order number

Shaft support extrusion 40x100  
Standard length 6100 mm L16-10-6.1M

Shaft support extrusion 40x100  
Cut to length L16-10-02-02/...

Extra machining [Pages 24-46](#)

### Shaft support extrusion 50x350 Type L16-15

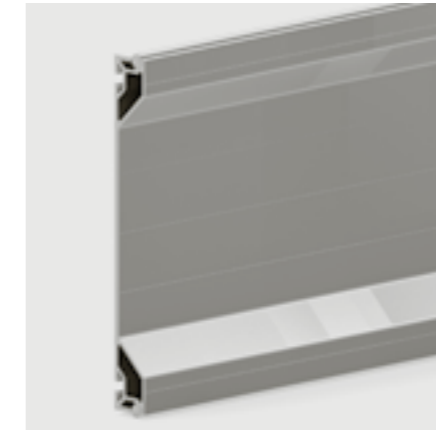
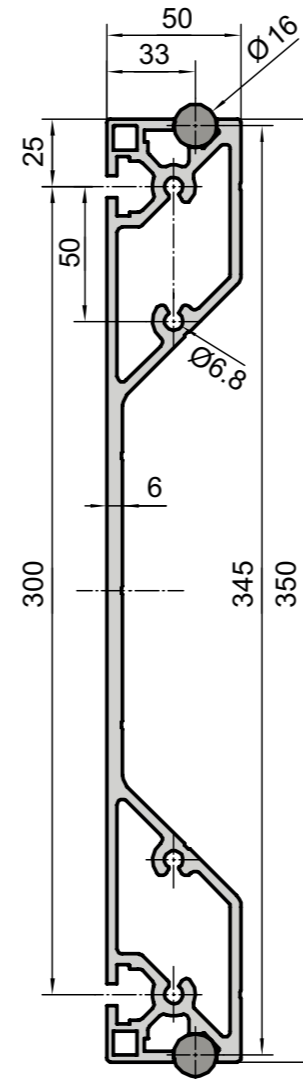

#### Application

With this guide profile, the shafts are pressed in on both sides. For this guidance, the slide plates or the slide construction must be specially designed in each case, therefore these are only available on request.

#### Technical data

$I_x$	=	5400.00 cm <sup>4</sup>
$I_y$	=	107.00 cm <sup>4</sup>
$W_x$	=	308.00 cm <sup>3</sup>
$W_y$	=	123.20 cm <sup>3</sup>
Cross-section area	=	37.40 cm <sup>2</sup>
Weight	=	10.13 kg/m

#### Order data Order number

Shaft support extrusion L16-15  
Standard length 5800mm L16-15-5.8M

Shaft support extrusion L16-15  
Cut to length L16-15-02-02/...

### Shaft support extrusion 35x300 Type L12-10

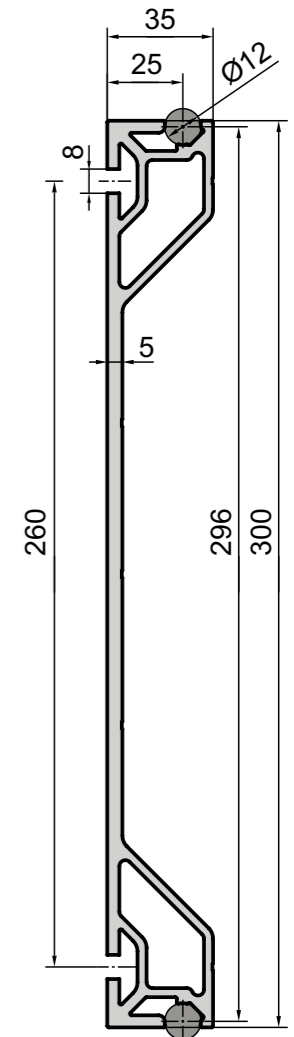

#### Technical data

$I_x$	=	2768.00 cm <sup>4</sup>
$I_y$	=	28.90 cm <sup>4</sup>
$W_x$	=	184.50 cm <sup>3</sup>
$W_y$	=	17.00 cm <sup>3</sup>
Cross-section area	=	24.78 cm <sup>2</sup>
Weight	=	6.71 kg/m

#### Order data Order number

Shaft support extrusion L12-10  
Standard length 4400 mm L12-10-4.4M

Shaft support extrusion L12-10  
Cut to length L12-10-02-02/...

#### Load rating

dynamic	static
850 N	620 N

#### Order data Order number

Linear sliding block L16-68

#### Technical data

$I_x$	=	172.22 cm <sup>4</sup>
$I_y$	=	31.92 cm <sup>4</sup>
$W_x$	=	33.83 cm <sup>3</sup>
$W_y$	=	15.95 cm <sup>3</sup>
Cross-section area	=	16.75 cm <sup>2</sup>
Weight	=	4.5 kg/m

## Shaft clamping extrusions

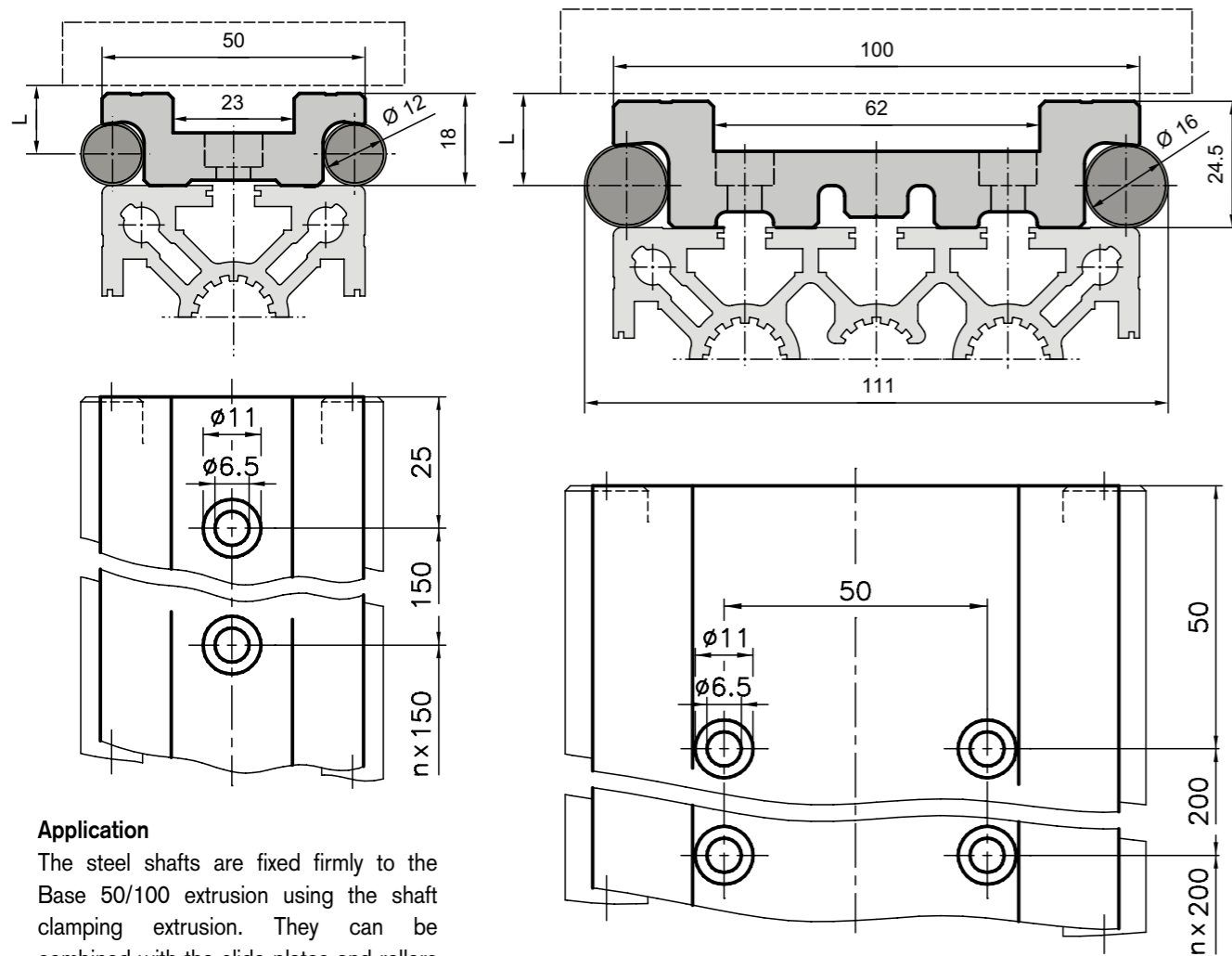

### Application

The steel shafts are fixed firmly to the Base 50/100 extrusion using the shaft clamping extrusion. They can be combined with the slide plates and rollers as a simple way to create linear slides to move very high loads.

### Specification

Aluminium, matt, anodised in natural colours  
Pre-drilled mounting holes

Order data	Order number
Shaft clamping extrusion	50 mm base
Standard length 6000 mm	L12-05-6M
Cut to length	L12-05-02-02/...
Shaft clamping extrusion	100 mm base
Standard length 6000 mm	L16-05-6M
Cut to length	L16-05-02-02/...



### Specification

Shaft clamping extrusion complete with steel shafts Cf 53, hardened, ground and with fixing kit.

Order data	Order number
Steel clamping extr., compl.	50 mm base
Standard length 6000 mm	L12-06-6M
Cut to length	L12-06-02-02/...
Steel clamping extr., compl.	100 mm base
Standard length 6000 mm	L16-06-6M
Cut to length	L16-06-02-02/...

## Slide plates

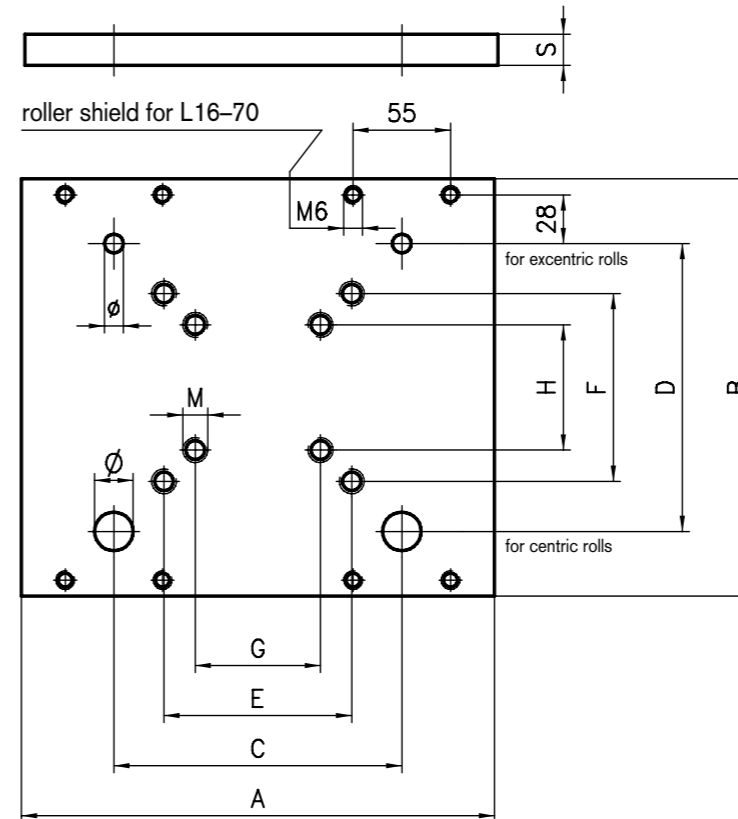

Order data	Order number	Scope of supply of L12-70
Slide plate cpl. to shaft	L12-70	1 1 plate L12-30
clamping extrusion L12-05		2 2 centric rollers L12-25
		3 2 excentric rollers L12-26
		4 2 slide plates for grease scraper L16-43
		5 4 grease scraper including fixing kit. L12-46

### Measurement data

Slide plates to shaft clamping extrusion													
Base	A	B	C	D	E	F	G	H	M	s	Ø	ø	Weight
50	150	130	110	89	60	60	30	30	8	12	12	10	0.6 kg
100	300	240	200	158	100	100	50	50	8	15	20	17	2.9 kg

Order data	Order number	Scope of supply of L16-70
Slide plate cpl. to shaft	L16-70	1 1 plate L16-31
clamping extrusion L16-05		2 2 centric rollers L16-25
		3 2 excentric rollers L16-26
		4 4 grease scraper including fixing kit. L16-45

### Application

The slide plate completes the desired linear guide. It is characterized by its high load capacity.

### Specification

Aluminium, raw

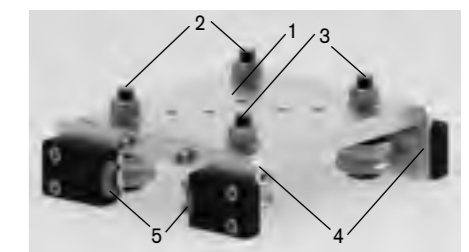
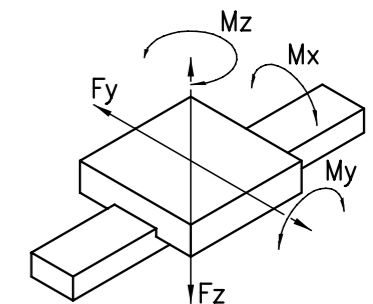

### Loads and moments

static [N/Nm]					dynamic [N/Nm]				
F <sub>y</sub>	F <sub>z</sub>	M <sub>x</sub>	M <sub>y</sub>	M <sub>z</sub>	F <sub>y</sub>	F <sub>z</sub>	M <sub>x</sub>	M <sub>y</sub>	M <sub>z</sub>
3000	1920	35	55	90	3000	1200	22	34	90
7200	3400	105	160	600	7200	2100	65	100	600

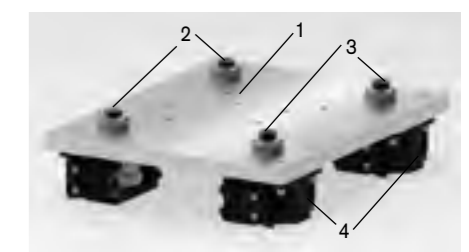



### Shaft clamping extrusions 2-part Ø16

### Shaft clamping extrusions Ø12

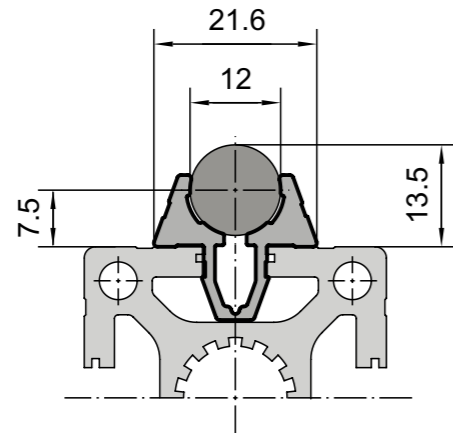
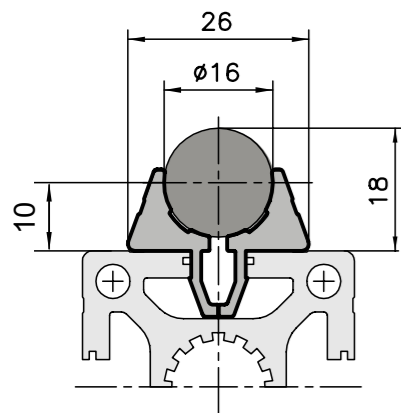

**Application**

For simple linear guides. The two-part shaft clamping extrusion is used to clip steel shafts Ø16 into all slots of 40 and 50 base extrusions. The beam extrusion can be freely selected depending on the strength requirements. Measure L determines the rollers illustrated on page 114 which are also required.



**Specification**

Aluminium, matt, anodised in natural colours

**Order data**      **Order number**

**Shaft clamping extrusion, 2-part**  
 Standard length 6000 mm    L16-01-6M  
 Cut to length                    L16-01-02-02/...

**Shaft clamping extrusion L12-01**  
 Standard length 6000 mm    L12-01-6M  
 Cut to length                    L12-01-02-02/...

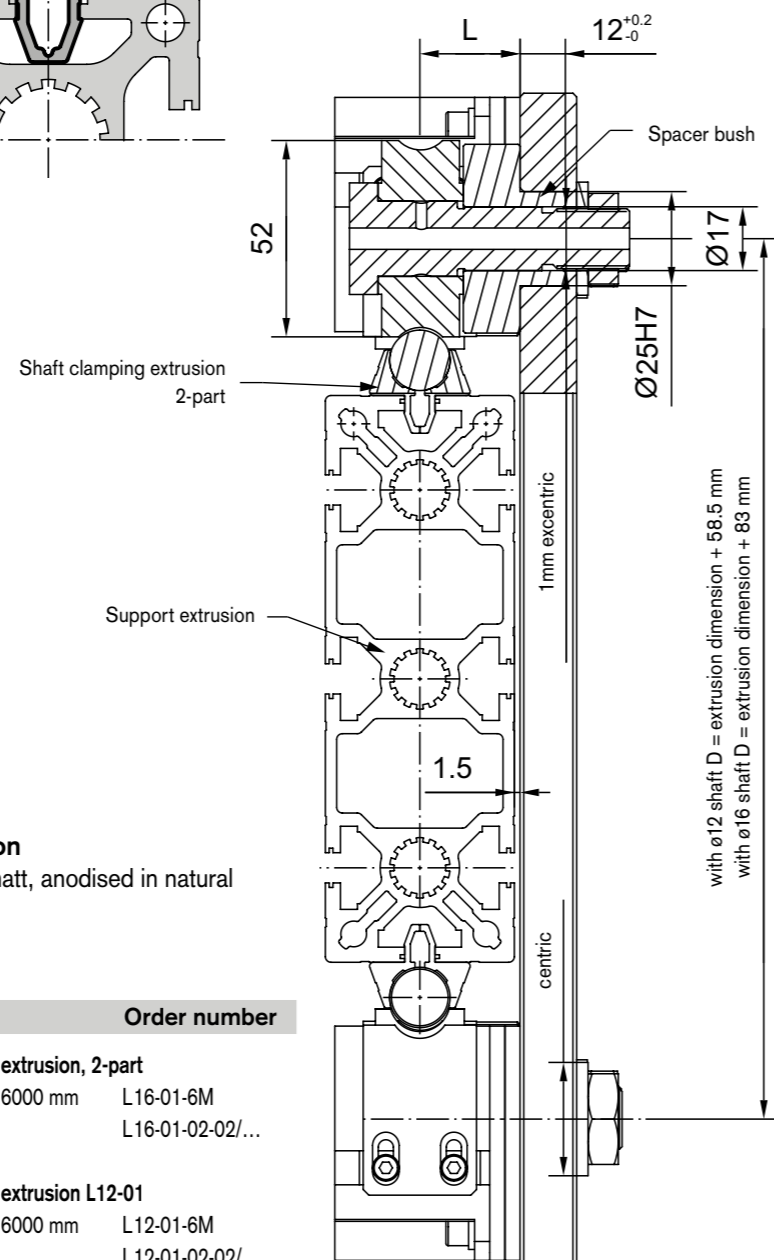

### Slide plates

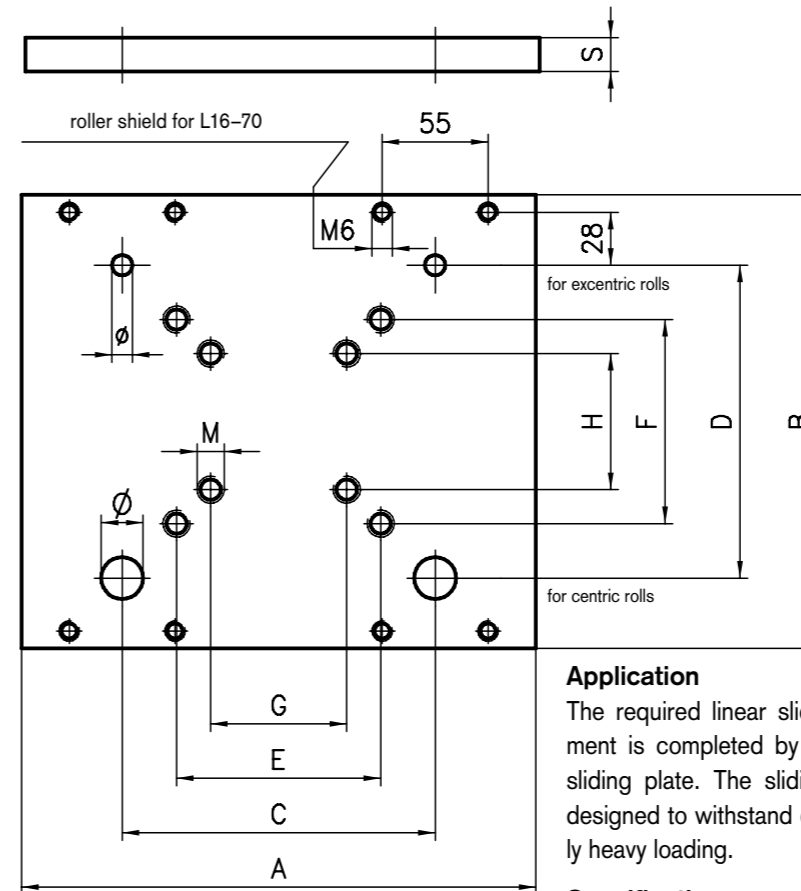

**Application**

The required linear slide arrangement is completed by use of the sliding plate. The sliding plate is designed to withstand exceptionally heavy loading.

**Specification**  
 Raw aluminium

**Measurement data**

Slide plates to shaft clamping extrusion 2-part Ø16 L16-01													
Size	A	B	C	D	E	F	G	H	M	s	Ø	Ø	Weight
50x150	350	310	250	233	150	150	75	75	8	15	*	*	4.3 kg
40x160	350	320	250	243	150	150	75	75	8	15	*	*	4.5 kg
Slide plates to shaft clamping extrusion L12-01													
Size	A	B	C	D	E	F	G	H	M	s	Ø	Ø	Weight
50x150	350	300	250	208.5	150	150	75	75	8	15	12	10	4.2 Kg
40x160	350	310	250	218.5	150	150	75	75	8	15	12	10	4.4 Kg

\*Drill according to sectional view on page 210.  
 Load details must be requested separately due to the selected support extrusion.

**Order data**

Support type	L16-01 (Ø16)	L12-01 (Ø12)
Support extrusion		
50x150	L16-71	L12-71
40x160	L16-72	L12-72

Further support extrusion and slide plates on request.

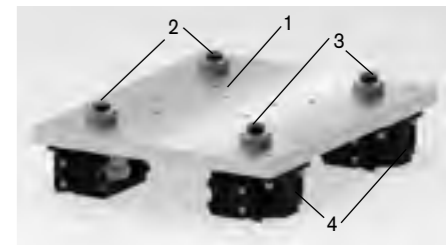

**Order data**      **Order number**

**To extrusion 50x150mm Ø16**  
**Slide plate cpl.**                    L16-71  
**Parts supplied**  
 1 1 plate                            L16-35  
 2 2 centric rollers                L16-27  
 3 2 eccentric rollers              L16-28  
 4 4 roller cover                    L16-45  
     with grease scraper and fixing kit.

**To extrusion 40x160mm Ø16**  
**Slide plate cpl.**                    L16-72  
**Parts supplied**  
 1 1 plate                            L16-34  
 2 2 centric rollers                L16-21  
 3 2 eccentric rollers              L16-22  
 4 4 roller cover                    L16-45  
     with grease scraper and fixing kit.

**To extrusion 50x150mm Ø12**  
**Slide plate cpl.**                    L12-71  
**Parts supplied**  
 1 1 plate                            L12-35  
 2 2 centric rollers                L12-27  
 3 2 eccentric rollers              L12-28  
 4 4 roller cover                    L12-47  
     with grease scraper and fixing kit.

**To extrusion 40x160mm Ø12**  
**Slide plate cpl.**                    L12-72  
**Parts supplied**  
 1 1 plate                            L12-34  
 2 2 centric rollers                L12-21  
 3 2 eccentric rollers              L12-22  
 4 4 roller cover                    L12-47  
     with grease scraper and fixing kit.

## Rollers

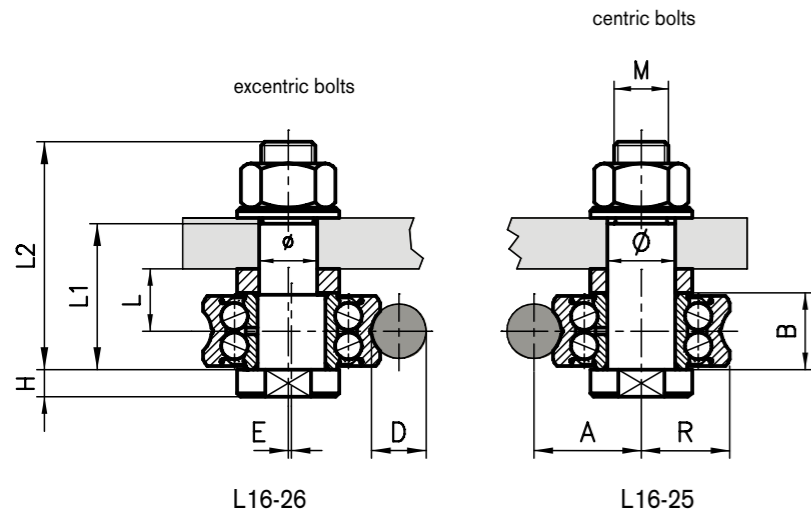

### Rollers for bar Ø16

L = 18.5 for shaft clamping extrusion	L16-25	L16-26
L = 21.5 2-part shaft clamping extrusion base 40 L12-01	L16-21	L16-22
L = 26.5 2-part shaft clamping extrusion base 50 L16-01	L16-27	L16-28

Measurement data													Load rating	
D	A	B	E	H	L1	L2	M	R	Ø	ø	Weight	dyn.	stat.	
ø12	21.75	15.9	0.75	5	29	45	M10x1.5	17.5	12H7	10H7	0.15 kg	8400 N	5000 N	
ø16	31.5	22.6	1.0	8	44	67	M16x1.5	26	20H7*	17H7	0.42 kg	16800 N	9500 N	

\* Counter sunk drilling

Order data		Order number	
<b>Roller for bar Ø12 L12-35</b>		<b>centric</b>	<b>eccentric</b>
L = 14		L12-25	L12-26
Roller for base 40		L12-21	L12-22
Roller for base 50		L12-27	L12-28
<b>Roller for bar Ø16 L16-35</b>			
L = 18.5 to shaft clamping extrusion		L16-25	L16-26
L = 21.5 to shaft clamping extrusion two-part base 40 L12-01		L16-21	L16-22
L = 26.5 to shaft clamping extrusion two-part base 50 L16-01		L16-27	L16-28



## Spacer for the roller shield

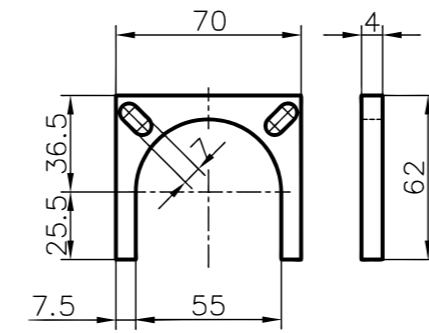

### Application

As a spacer for the roller shield to adjust the different sizes of the rollers.

### Specification

Aluminium, raw  
1 pc for roller L=21.5  
2 pc for roller L=26.5

Order data	Order number
Spacer	L16-40-04

## Grease scraper

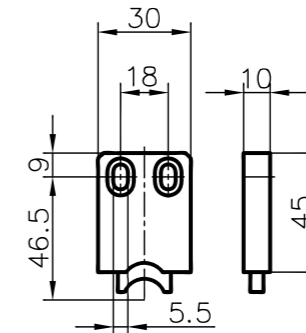

### Scope of supply

1 grease scraper  
2 cycl. screws M5 x 12



### Application

The grease scraper is for two functions. On one hand, it cleans the steel bars and on the other it coat the steel bars with a grease film to protect it from rusting.

### Specification

Shield: PA-GF  
grease scraper: grease-impregnated felt

Order data	Order number
Grease scraper Ø 16	L16-46
Grease scraper Ø 12	L12-46

## Grease scraper support

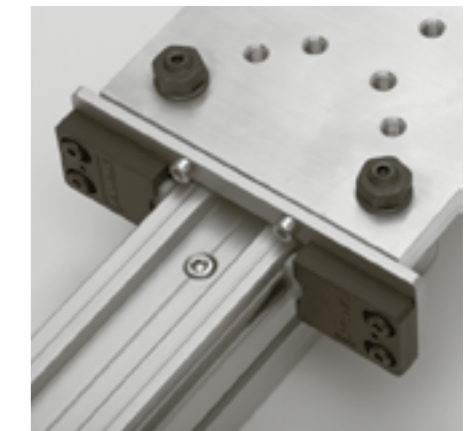
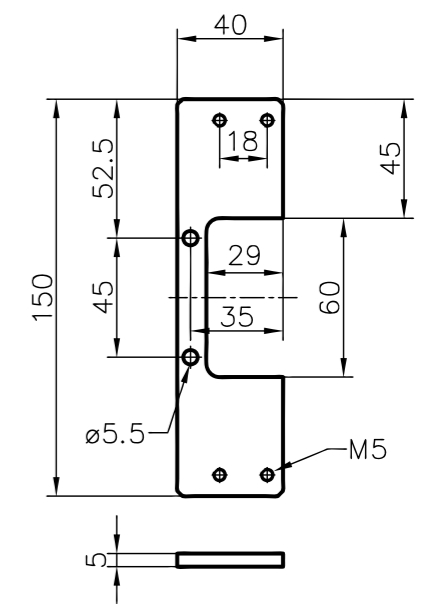

### Application

The support fits on the slide plate base 50 (L12-70). Together with the grease scraper the slide for a small linear guide is complete.

### Specification

Aluminium, anodised in natural colours

Order data	Order number
Support for grease scraper	L16-43

## Roller cover cpl. Ø16mm / Ø12mm

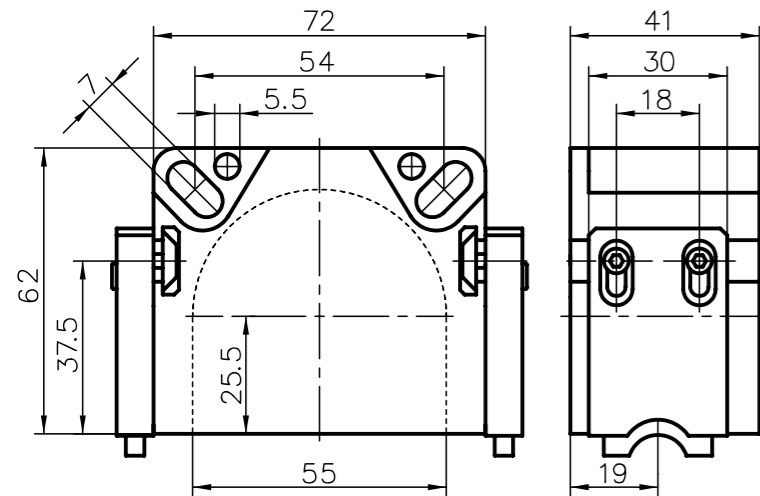

### Application

This cover offers protection against dust and other contamination. The lateral grooves are envisaged to affix the oil strippers.

### Specification

PA-GF, black

### Scope of supply

- 1 roller cover
- 2 grease scraper
- 4 cyl. screws
- 4 threaded plates

Weight: ca. 0.05 kg

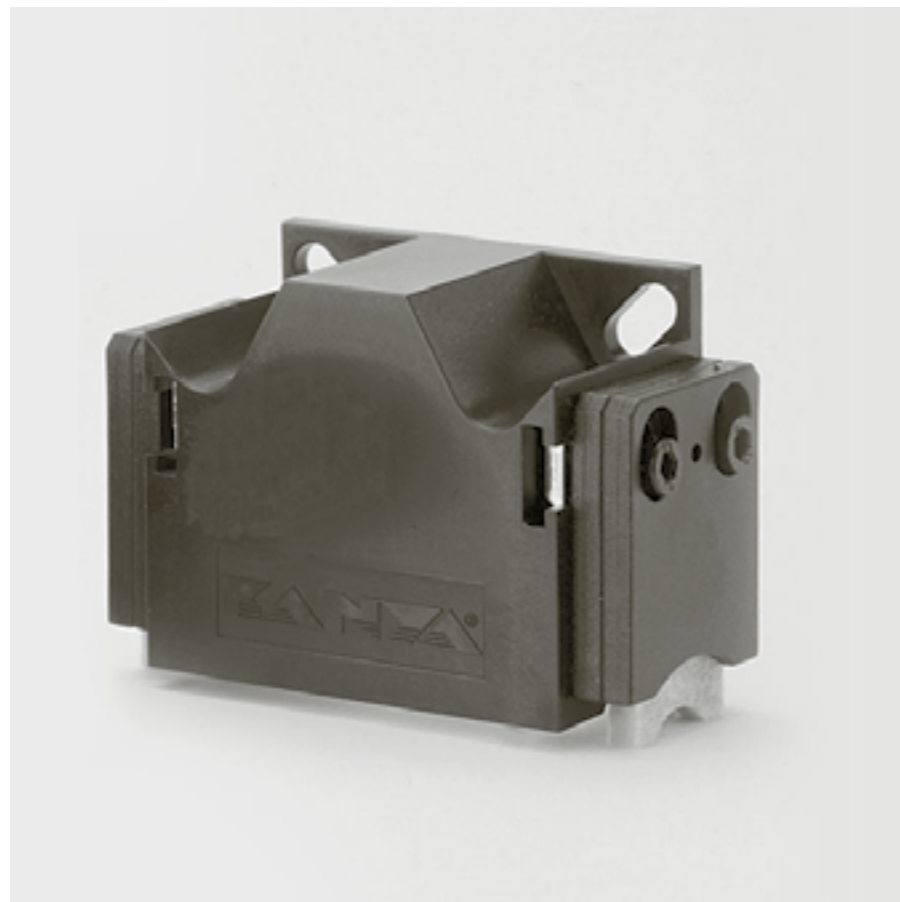

Order data	Order number
------------	--------------

Roller cover cpl. for Ø16 shaft	L16-45
------------------------------------	--------

Roller cover cpl. for Ø12 shaft	L12-45
------------------------------------	--------

## End stop

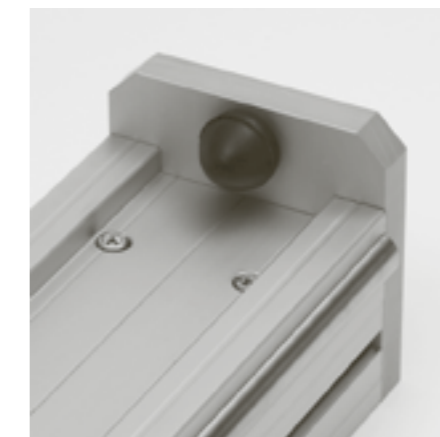
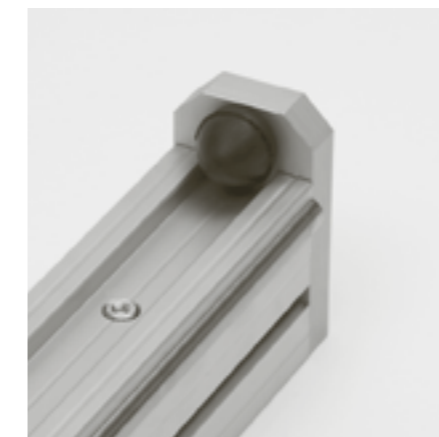
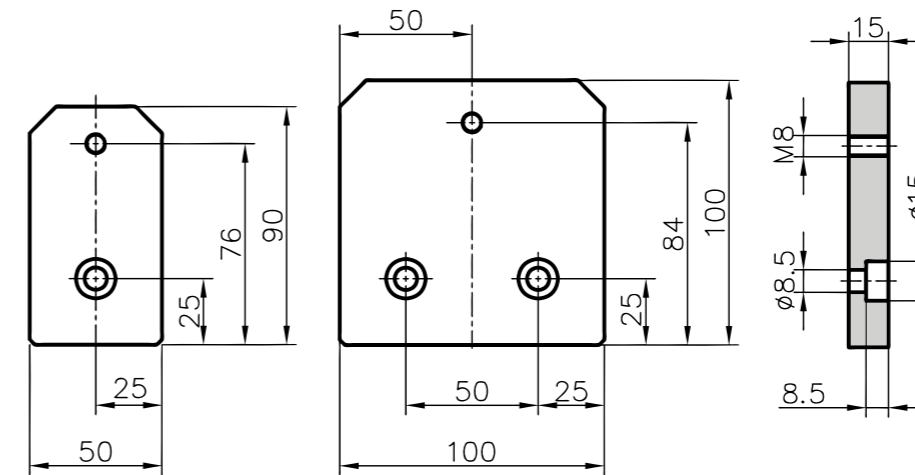

### Application

The end stopper in combination with the buffer is normally screwed on the end of the extrusions base 50, serving as a stop for the linear guides.

### Specification

Aluminium, anodised in natural colours

Order data	Order number
------------	--------------

End stop 50	L16-55
End stop 100	L16-53

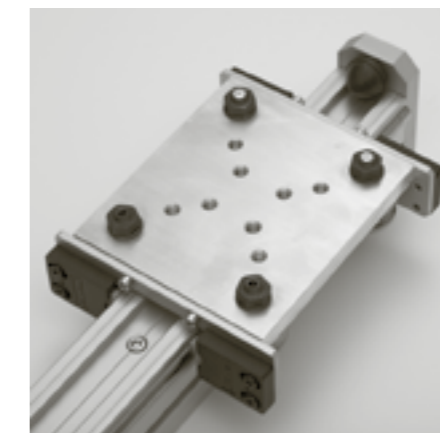

## Buffer

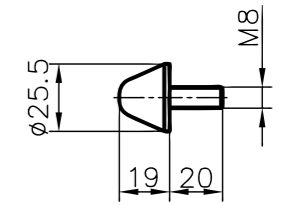

### Application

For use as an end stop for linear guides

### Specification

rubber, highly deformable

Order data	Order number
------------	--------------

Buffer	L16-50
--------	--------

## C-guide rails

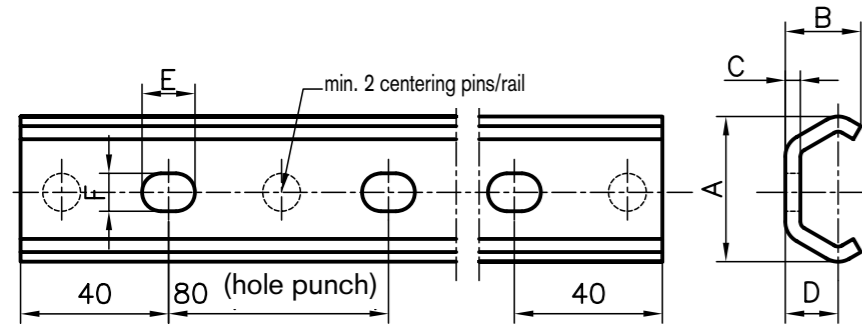

### Measurement data

Size	A	B	C	D	E	F	kg/m
20	19.2	10	2	7	7	5	0.47
30	29.5	15	2.5	10	8.4	6.4	0.9
45	46.4	24	4	15.5	11	9	2.3

### Application

The guide rail can be subjected to high loads thanks to its optimum shaping. It is screwed directly onto the structure extrusions. Centering pins align the rail parallel with the extrusion.

Combined with the suitable slides, it is possible to produce accurate and inexpensive linear guides. Three sizes are available.

### Specification

Stainless steel

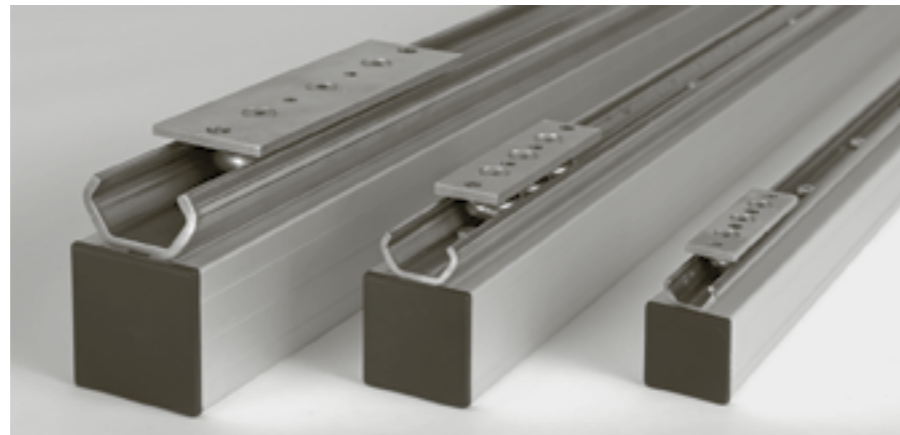

### Order data

Order data	Order number
<b>Size 20</b>	
Standard length 4000 mm	L20-01-4M
Cut to length	L20-01-02-02/...
<b>Size 30</b>	
Standard length 4000 mm	L30-01-4M
Cut to length	L30-01-02-02/...
<b>Size 45</b>	
Standard length 6080 mm	L45-01-6.08M
Cut to length	L45-01-02-02/...

## Slides

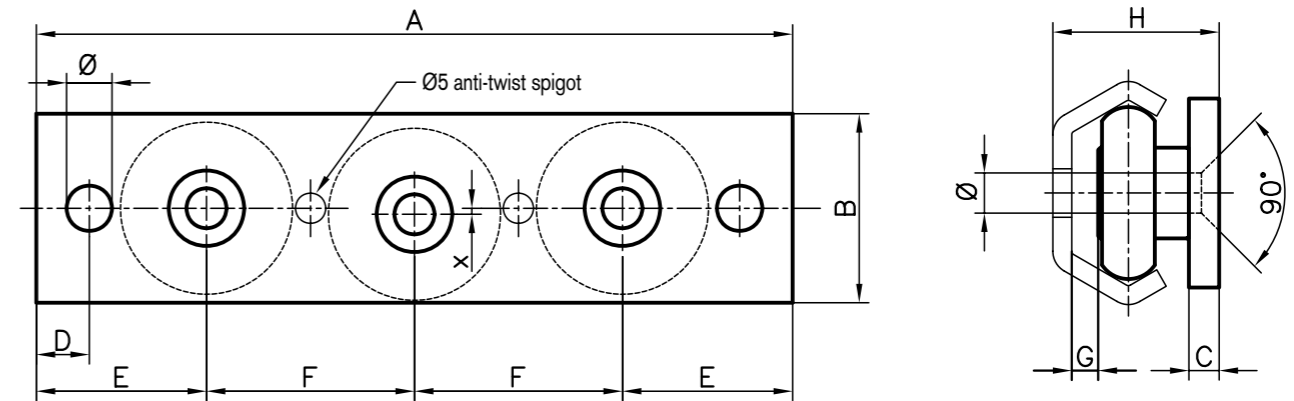

### Measurement data

Size	A	B	C	D	E	F	G	H	Ø	ø	x
20	75	18	3	6	18.5	19	2.5	16	5.2	4.5	0.5
30	96	25	4	6	23.5	24.5	3.5	22	6.2	5.5	0.5
45	155	45	4	8	34	43.5	5	31	8.2	6.6	0.6

### Load ratings

Size	F <sub>red</sub>	F <sub>ex</sub>
20	300N	170N
30	800N	400N
45	1600N	860N

### Application

Mainly for horizontal and vertical guides, in particular for drawer runners subjected to heavy loads, lifting and sliding doors as well as height adjustable work benches, or any application where larger loads need to be moved back and forth.

### Specification

Stainless steel

Other slide dimensions available on request.

### Order data

Order data	Order number
<b>Slide including rollers</b>	
Size 20	L20-20
Size 30	L30-20
Size 45	L45-20

### Technical data

Temperature range:  
-20°C to max. +100° C max.  
Displacement speed: 1.5 m/s

The flat slide means the design is compact. It is screwed directly onto the structure extrusions. Two anti-twist spigots position the slide parallel to the extrusion.

Both outer rollers support the load. Markings show the contact side to the guide rail. The middle roller can be set to the desired preload using the excentric screw.

## Roller system

### Application

The roller tracks, together with special clamps, are simply mounted to the Kanya 50, 40 and 30 base aluminium extrusions.

The roller track system can be used for all types of conveyance and removal of material and goods. Examples of typical applications

- Roller transport via gravity for all types of boxes
- Roller transport connections between workstations
- Roller conveyance to work benches
- Material roller transport within a machine production plant
- Accurate positioning of boxes

The range includes rollers with and without guide flange. All roller tracks are also available as ESD version.

### Technical description

Roller tracks are made from bent steel sheets, galvanised, 0.8mm, width 36mm, overall height 36mm  
 Axes made from zinc-coated steel, diameter 3mm  
 Bore holes with diameter 4.1mm at the base of the roller track  
 Vertical load up to 40 kg per roller (lying on flat surface)

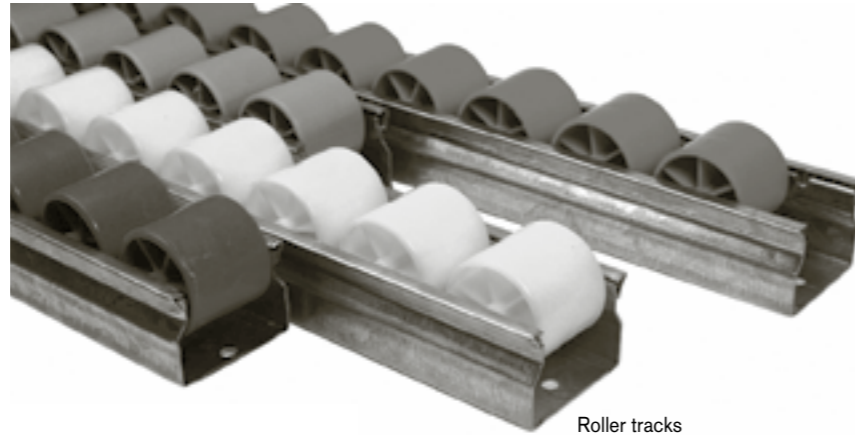

Roller tracks

### Product advantages

The special shape of the steel sheet allows the roller track to close when under load. This significantly increases the resistance against twisting or bending.

### Loads

The roller tracks (one pair) can be subjected to loads as follows, according to the length – see table below.

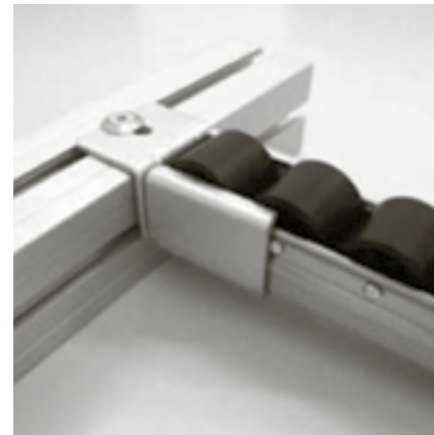

Clamping for easy fixing of roller tracks to extrusions and tubes.

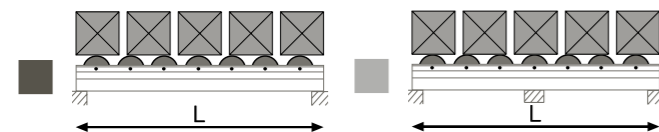

### Measurement data

L (mm)	1.500	1.400	1.300	1.200	1.100	1.000	900	800	700	600	500				
Σ Kgs.	75	80	88	95	105	117	130	153	177	212	250				
L (mm)	3.000	2.800	2.600	2.400	2.200	2.000	1.800	1.600	1.500	1.400	1.300	1.200	1.100	1.000	
Σ Kgs.	132	148	164	185	205	230	259	304	356	400	450	500	550	600	

## Roller tracks, flat

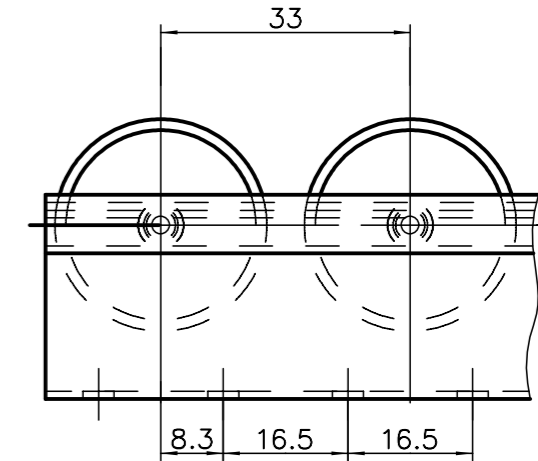
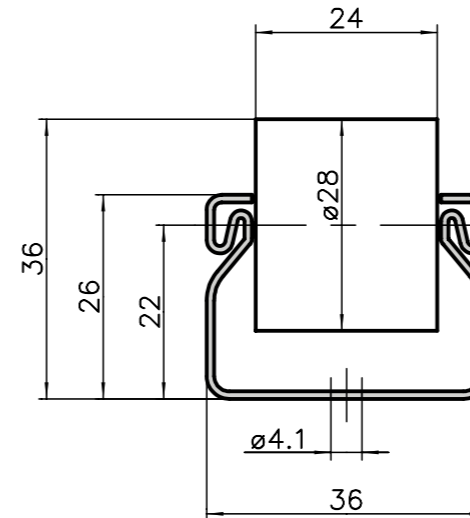

### Application

These roller tracks are ideal for use with storage and transportation racks. For lightweight transport of items, this self-supporting rail can be used for up to 3m. For packaging tables, assembly workstations and devices in process operations, these simplify the transport of goods and logistics.

### Specification

Steel rail  
 Plastic rollers with steel axes

### Technical description

Distance between roller axes is 33mm, weight: 0.86 kg/m; rollers made of polypropylene, diameter 28mm, width 24mm, ESD version with electrostatic discharge (resistance coefficient during throughput of electricity of 28.8Ω/cm<sup>2</sup>)

Rollers available in other colours on request when ordering more than 300 m.

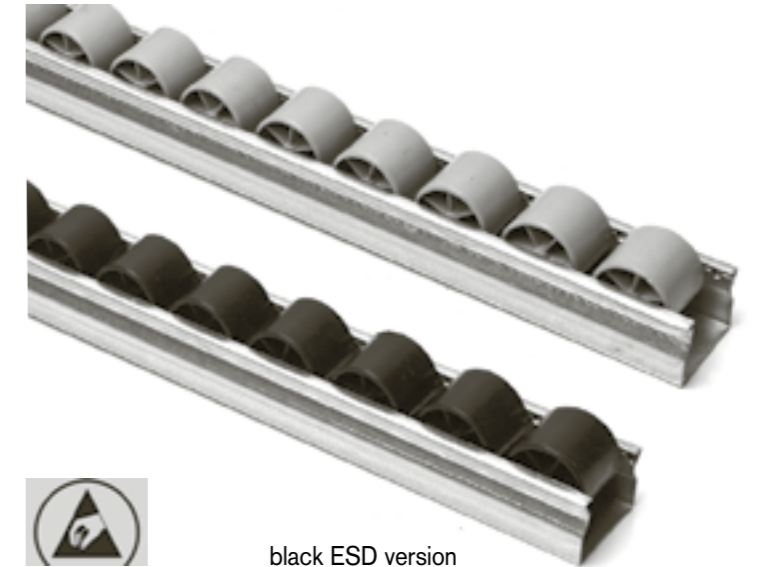

black ESD version

Order data	Order number
<b>Roller track</b>	
Standard length	L80-1-3M
Cut to length	L80-1-02-02/...
<b>ESD roller track</b>	
Standard length	L80-1-ESD-3M
Cut to length	L80-1-ESD-02-02/...

## Roller tracks with guide flange

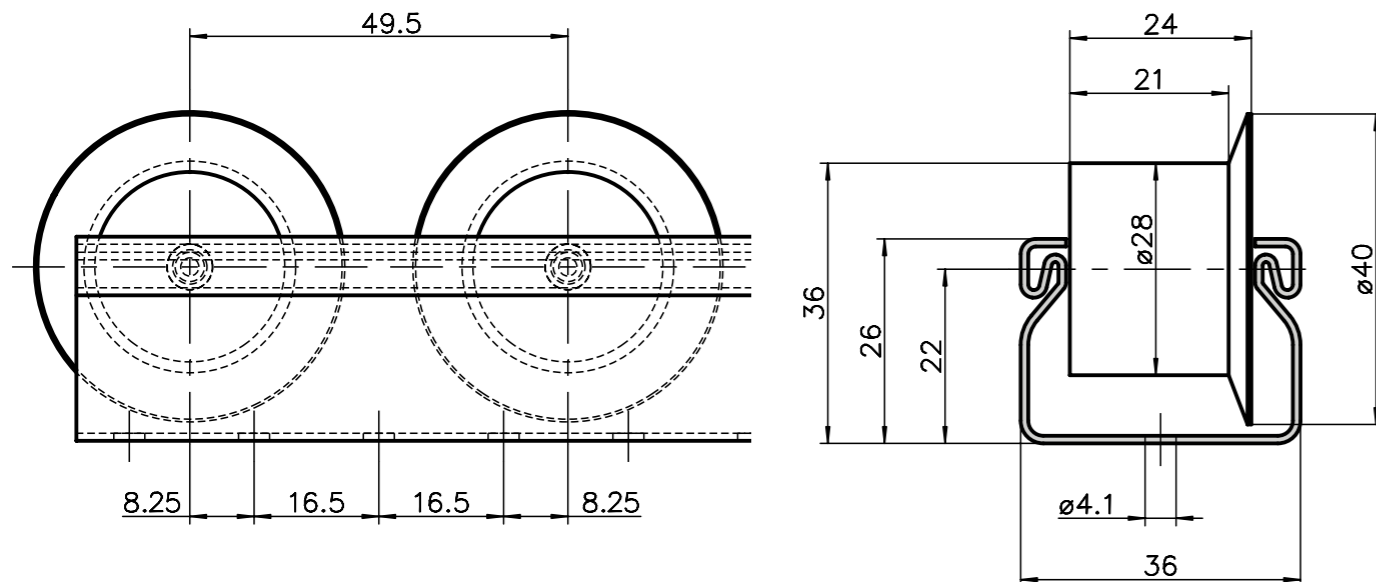

### Application

These roller tracks are ideal for use with storage and transportation racks. Light-weight transport of items is kept within the track by the side guide.

### Specification

Steel rail  
Plastic rollers with steel axes



### Technical description

Distance between roller axes is 49.5 mm, weight: 0.9 kg/m; rollers made of polypropylene, diameter 28mm, width 25mm. ESD version with electrostatic discharge (resistance coefficient during throughput of electricity of 28.8Ω/cm<sup>2</sup>).

Rollers available in other colours on request when ordering more than 300 m.

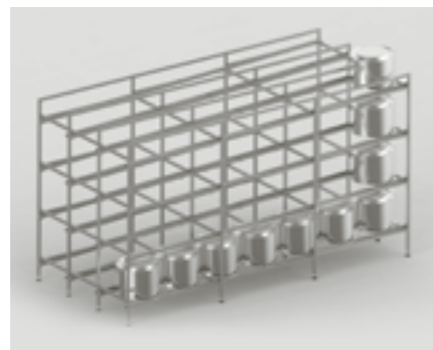

Order data	Order number
<b>Roller track with guide flange</b>	
Standard length	L80-2-3M
Cut to length	L80-2-02-02/...
<b>Roller track with ESD guide flange</b>	
Standard length	L80-2-ESD-3M
Cut to length	L80-2-ESD-02-02/...

## Roller track adapter type L80-90

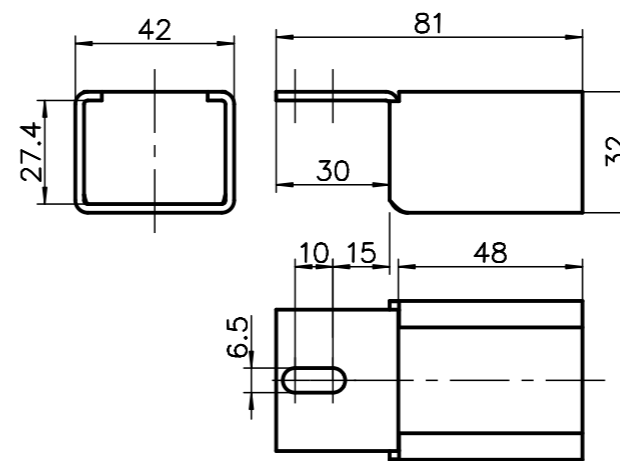

### Application

This roller track adapter can be screwed onto the 30/40/45/50 series base extrusions. The roller tracks are pushed in and attached to an extrusion structure.

Replacing or moving them is simple.

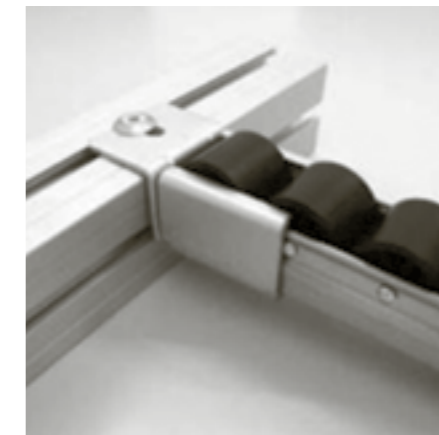

Order data	Order number
Roller track adapter	L80-90



## Roller holder

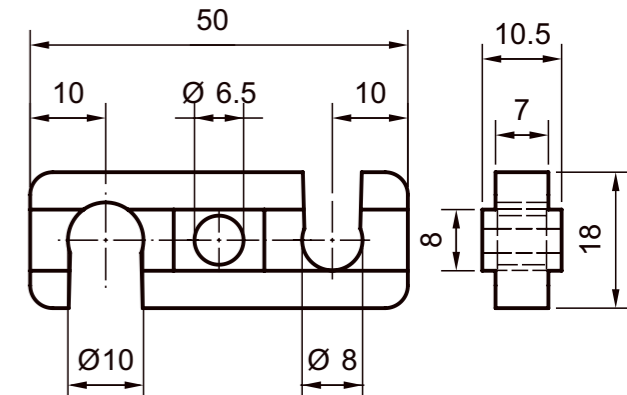

### Application

The roller holder can be attached to our 8 nut with only one screw and one nut securely fastened and a sliding block. It accepts axles with a diameter of 8 and 10mm. Thanks to its symmetrical design, the holder can be used on both sides. This means that roller tracks can be easily realised.

### Material

Standard: PA6 G15 black  
ESD version: PA66 CF15 black

### Version

Plastic roller holder



Order data	Order number
Roller holder	C49-00
Roller holder ESD	C49-01 ESD

## Roller stopper

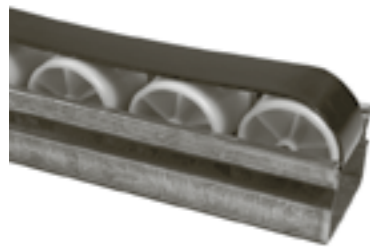
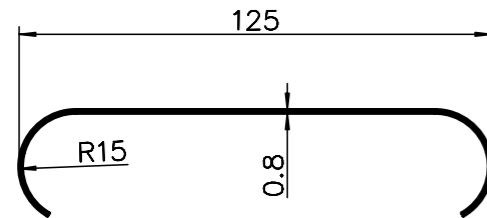

### Application

This roller stopper can be used to finish off the roller tracks to make it easier to remove containers, transportation boxes or packages. The goods being transported slides onto the roller stop and comes to a standstill. The items being transported can now be removed without having to lift them.

## Anti-return

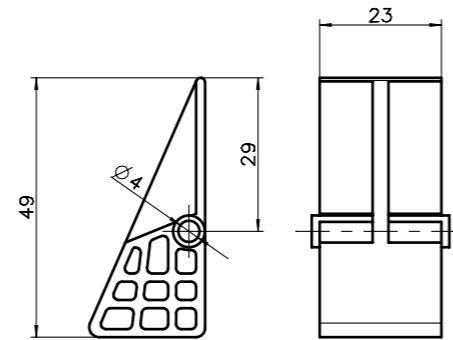

### Application

This element prevents the return of the item being transported. Installed in the right place, this easy-to-install element offers a great solution to the flow of material.

This product can also be used as a simple stop at the end of a roller track to prevent boxes or containers from falling off.

Order data	Order number
------------	--------------

Roller stopper	L80-30
----------------	--------

Order data	Order number
------------	--------------

Anti-return	L80-31
-------------	--------



**Tube clamp system**  
**RVS®**

## Extrusion tolerances – extract from EN 12020-02

### 1. Straightness tolerances

Cavity extrusions shall not exceed the values stated in the table for straightness tolerances  $h_1$ . The deviation  $h_2$  shall not exceed a maximum of 0.3 mm over any length of  $l_2 = 300$  mm.

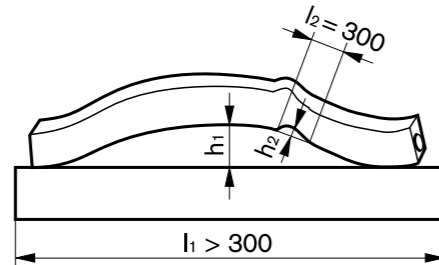

### 3. Angular Tolerance $w$

If side lengths are unequal, the angular tolerance relates to the angle of the shorter side.



Width b in mm		Inclination tolerance w in mm
over	up to	
-	30	0.3
30	50	0.4
50	80	0.5
80	100	0.6
100	120	0.7

### 2. Distortion Tolerance $v$

The distortion tolerance  $v$  for cavity extrusions subject to length is shown in the table.

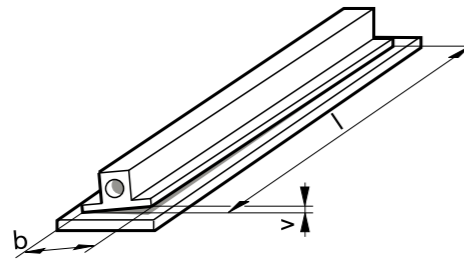

### 4. Diameter D/D1 Tolerances

The tolerances shown in the Table below relate to the Diameter D/D1 in each case, as shown in the technical drawings.

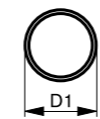
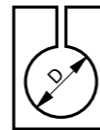

Diameter D/D1 in mm	D Tolerance in mm	D1
12	0 / +0.05	0 / -0.1
15	0 / +0.05	0 / -0.1
20	0 / +0.1	0 / -0.15
30	0 / +0.1	0 / -0.2
40	0 / +0.1	0 / -0.2
50	0 / +0.1	0 / -0.2

Width b in mm Measurement Range		Flatness Tolerance v in mm for lengths in mm		
over	up to	bis 1000	over 1000 up to 2000	over 2000 up to 3000
-	25	1.0	1.5	1.5
25	50	1.0	1.2	1.5
50	75	1.0	1.2	1.2
75	100	1.0	1.2	1.5
100	125	1.0	1.5	1.8

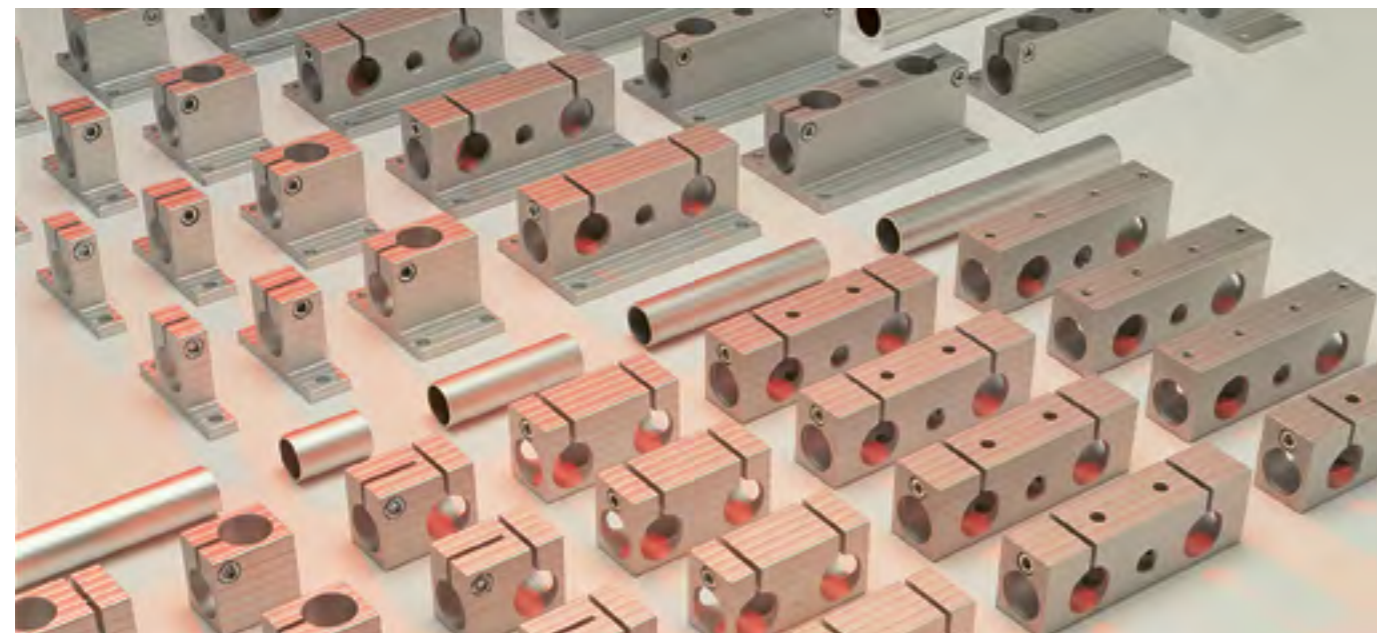

## Clamp Ring

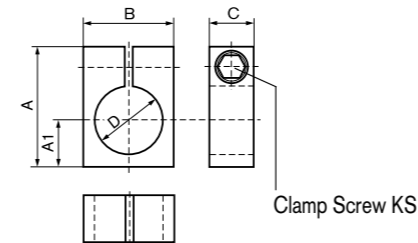

### Use

Normally used as a stop, or as a holder for limit switches or similar.

Nominal Diameter	Dimensions						Weight in kg	Order number
	A	A1	B	C	D	KS		
12	24	8	16	32	12	M4	-	on request
20	36	13	30	20	20	M6	0.045	R02-15
30	52	20	40	20	30	M8	0.080	R03-15
40	62	25	50	20	40	M8	0.105	R04-15
50	72	30	60	20	50	M8	0.135	R05-15

## Joining Clamp

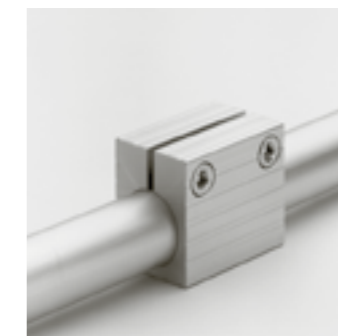
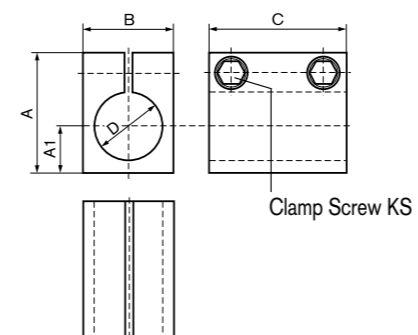

### Use

To extend tubes and as a stop for large forces.

Nominal Diameter	Dimensions						Weight in kg	Order number
	A	A1	B	C	D	KS		
12	24	8	16	32	12	M4	-	on request
20	36	13	30	40	20	M6	0.085	R02-01
30	52	20	40	60	30	M8	0.225	R03-01
40	62	25	50	80	40	M8	0.395	R04-01
50	72	30	60	100	50	M8	0.625	R05-01

For diameter D tolerances, see page [120](#)



### Angle Clamp

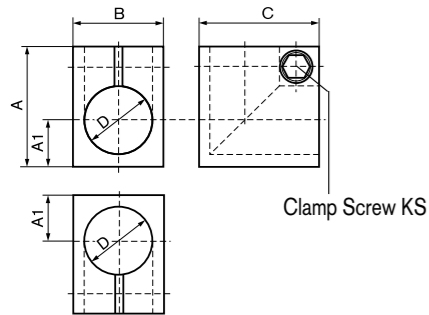

**Use**

Attractive corner joint for normal loads.

For reasons of stability, it is recommended that tubes in angle clamp joints are cut at 45°.

Nominal Diameter	Dimensions					KS	Weight in kg	Order number
	A	A1	B	C	D			
12	24	8	16	32	12	M4	-	on request
20	36	13	30	36	20	M6	0.060	R02-02
30	52	20	40	52	30	M8	0.150	R03-02
40	62	25	50	62	40	M8	0.225	R04-02
50	72	30	60	72	50	M8	0.320	R05-02

### Parallel Clamp

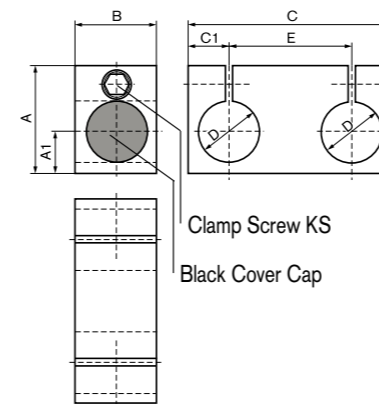

**Use**

To strengthen structures (by doubling) or to extend tubes on different levels.

Nominal Diameter	Dimensions							KS	Weight in kg	Order Number
	A	A1	B	C	C1	D	E			
12	24	8	16	42	9	12	24	M4	-	on request
20	36	13	30	66	13	20	40	M6	0.110	R02-04
30	52	20	40	100	20	30	60	M8	0.310	R03-04
40	62	25	50	130	25	40	80	M8	0.535	R04-04
50	72	30	60	160	30	50	100	M8	0.815	R05-04

### T Clamp

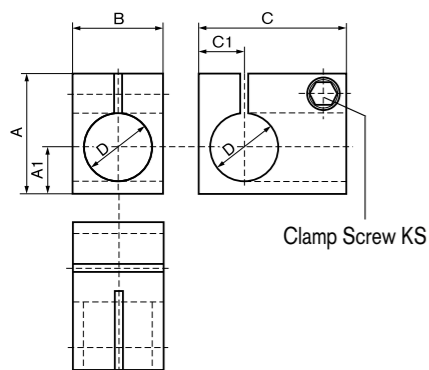

**Use**

Cross joints where only one tube needs to be movable.

Nominal Diameter	Dimensions					KS	Weight in kg	Order number
	A	A1	B	C	D			
12	24	8	16	32	12	M4	-	on request
20	36	13	30	45	13	M6	0.080	R02-03
30	52	20	40	65	20	M8	0.215	R03-03
40	62	25	50	85	25	M8	0.365	R04-03
50	72	30	60	105	30	M8	0.560	R05-03

### Cross Clamp

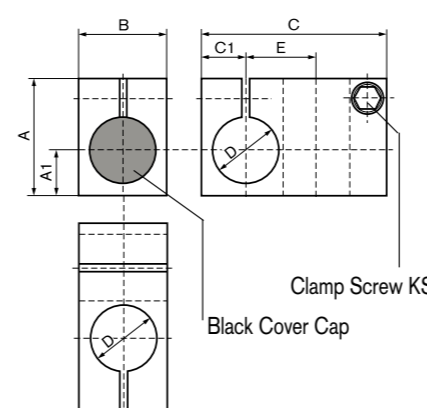

**Use**

This is the most frequently used clamp. It can hold two freely movable tubes, offset at 90°.

Nominal Diameter	Dimensions							KS	Weight in kg	Order Number
	A	A1	B	C	C1	D	E			
12	24	8	16	38	9	12	13	M4	0.022	R01-05
20	36	13	30	58	13	20	22	M6	0.095	R02-05
30	52	20	40	84	20	30	32	M8	0.235	R03-05
40	62	25	50	104	25	40	42	M8	0.370	R04-05
50	72	30	60	124	30	50	52	M8	0.535	R05-05

For diameter D tolerances, see page 120

For diameter D tolerances, see page 120

### Cross Clamp with different Ø

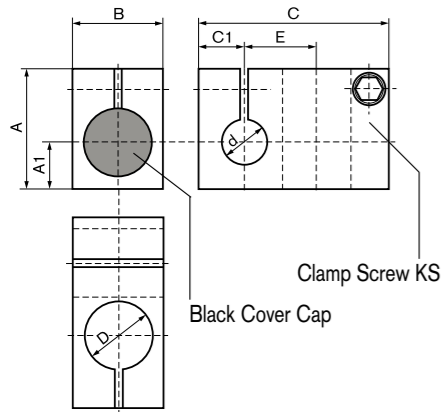

**Use**  
This is the most frequently used clamp. It can hold two freely movable tubes, offset at 90°.

Nominal Diameter	Dimensions		B	C	C1	D	d	E	KS	Weight in kg	Order Number
	A	A1									
20 / 12	36	13	30	58	13	20	12	22	M6	0.102	R02-07.12
30 / 12	52	20	40	84	20	30	12	32	M8	-	on request
30 / 20	52	20	40	84	20	30	20	32	M8	0.255	R03-07.20
40 / 20	62	25	50	104	25	40	20	42	M8	0.420	R04-07.20
40 / 30	62	25	50	104	25	40	30	42	M8	0.400	R04-07.30
50 / 40	72	30	60	124	30	50	40	52	M8	0.585	R05-07.40

For diameter D tolerances, see page [120](#)

### Cross T-Clamp

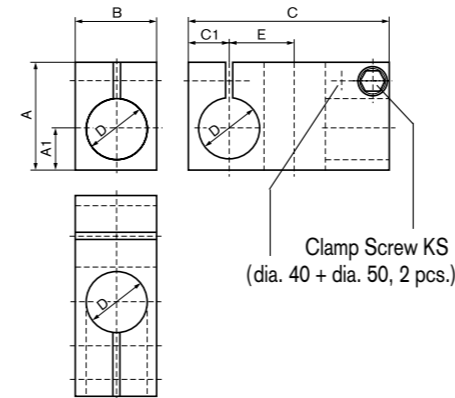

**Use**  
Tubes can exit from this clamp in three directions, but only the same two tubes as in the Cross Clamp (page [121](#)) pass all the way through the joint.

Nominal Diameter	Dimensions		B	C	C1	D	E	KS	Weight in kg	Order Number
	A	A1								
12	24	8	16	40	9	12	13	M4	-	on request
20	36	13	30	65	13	20	22	M6	0.105	R02-10 *
30	52	20	40	98	20	30	32	M8	0.285	R03-10 *
40	62	25	50	125	25	40	42	M8	0.470	R04-10 *
50	72	30	60	155	30	50	52	M8	0.730	R05-10 *

\* on request

### Universal Clamp

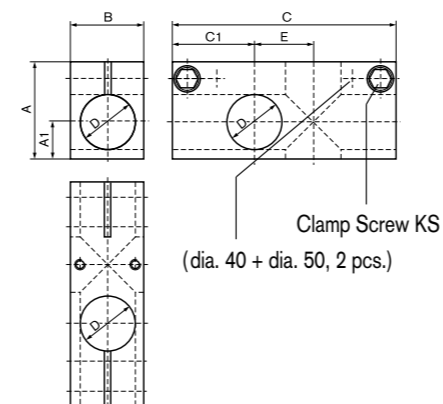

**Use**  
As its name implies, the four tube exits on this joint make it suitable for universal use.

Nominal Diameter	Dimensions		B	C	C1	D	E	KS	Weight in kg	Order Number
	A	A1								
12	24	8	16	53	20	12	13	M4	-	on request
20	36	13	30	82	30	20	22	M6	0.145	R02-11 *
30	52	20	40	122	45	30	32	M8	0.375	R03-11 *
40	62	25	50	162	60	40	42	M8	0.650	R04-11 *
50	72	30	60	202	75	50	52	M8	1.025	R05-11 *

\* on request

For diameter D tolerances, see page [120](#)

## Horizontal Clamp

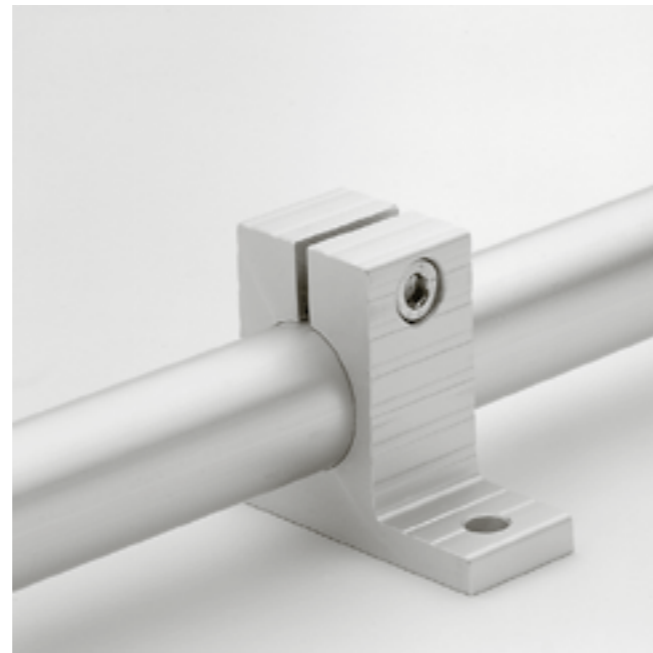
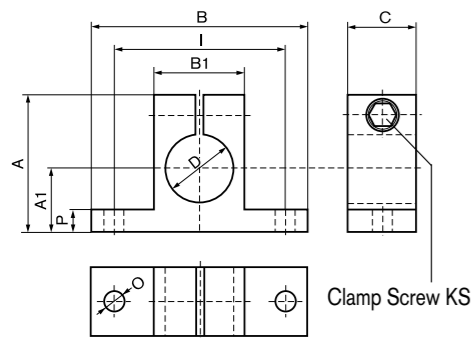

### Use

This joint is normally used as a pedestal bearing. However, it can also be used as a holder for screwed-on parts.

Nominal Diameter	Dimensions										Weight in kg	Order Number
	A	A1	B	B1	C	D	I	O	P	KS		
12	28	12	35	16	15	12	25	6	4	M4	0.015	R01-60
15	45	22	65	30	20	15	50	7	8	M6	0.088	R15-60
20	45	22	65	30	20	20	50	7	8	M6	0.080	R02-60
30	60	28	95	40	30	30	75	9	8	M8	0.170	R03-60
40	72	35	95	50	40	40	75	9	10	M8	0.295	R04-60
50	82	40	120	60	50	50	100	9	10	M8	0.470	R05-60

## Tube Cleat

Nominal Diameter	Dimensions										Weight in kg	Order Number
	A	A1	B	B1	C	D	I	O	P	KS		
30	60	28	95	40	20	30	75	9	8	M8	0.115	R03-65
40	72	35	95	50	20	40	75	9	10	M8	0.150	R04-65
50	82	40	120	60	20	50	100	9	10	M8	0.195	R05-65

For diameter D tolerances, see page [120](#)

## Vertical Clamp

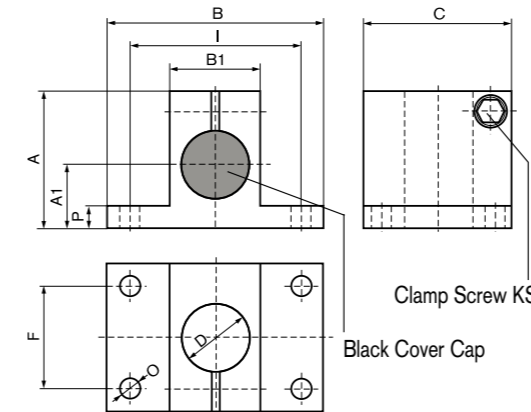

This is the elementary component for a wide variety of constructions, whether as a flange, a build-on joint or a holder.

Nominal Diameter	Dimensions										Weight		Order Number
	A	A1	B	B1	C	D	F	I	O	P	KS	in kg	
12	28	12	35	16	32	12	-	25	6	4	M4	0.029	R01-50
20	45	22	65	30	45	20	25	50	7	8	M6	0.135	R02-50
30	60	28	95	40	65	30	50	75	9	8	M8	0.310	R03-50
40	72	35	95	50	75	40	50	75	9	10	M8	0.440	R04-50
50	82	40	120	60	85	50	50	100	9	10	M8	0.610	R05-50

For diameter D tolerances, see page [120](#)

### End Swivel Clamp

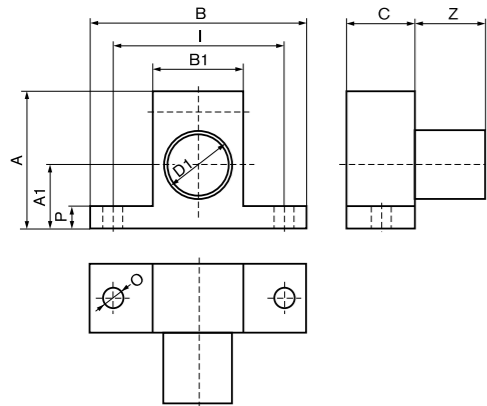

**Use**

The tube is firmly pressed into this clamp, making it particularly suitable for oblique connections. Can also be used for permanent swivel functions.

Nominal Diameter	Dimensions										Weight in kg	Order Number
	A	A1	B	B1	C	D1	I	O	P	Z		
12	28	12	35	16	15	12	25	6	4	17	-	on request
20	45	22	65	30	20	20	50	7	8	21	0.080	R02-70 *
30	60	28	95	40	30	30	75	9	8	31	0.190	R03-70 *
40	72	35	95	50	40	40	75	9	10	41	0.340	R04-70 *
50	82	40	120	60	50	50	100	9	10	51	0.585	R05-70 *

\* on request

### T-Swivel Clamp

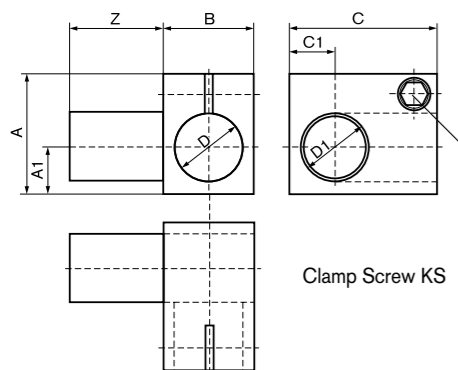

**Use**

Chiefly used where tubes coming out of the joint must be swivelled in connection with all the other clamp joints.

Nominal Diameter	Dimensions										Weight in kg	Order Number
	A	A1	B	B1	C	D1	I	O	P	Z		
12	24	8	16	30	9	12	12	17	M4	-	-	on request
20	36	13	30	45	13	20	20	31	M6	0.100		R02-13 *
30	52	20	40	65	20	30	30	41	M8	0.255		R03-13 *
40	62	25	50	85	25	40	40	51	M8	0.435		R04-13 *
50	72	30	60	105	30	50	50	61	M8	0.700		R05-13 *

\* on request

For diameter D tolerances, see page 120

### Cross Swivel Clamp

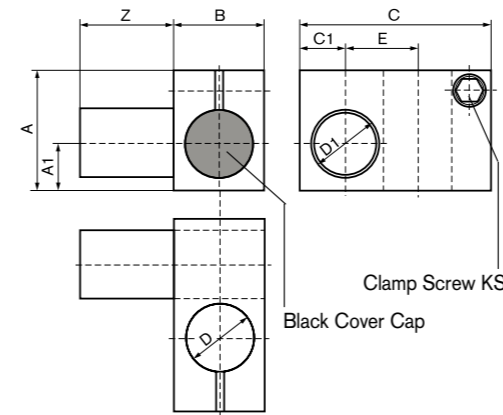

**Use**

To brace structures with oblique tube connections; also used like the T-swivel clamp.

Nominal Diameter	Dimensions										Weight in kg	Order Number
	A	A1	B	C	C1	D	D1	E	Z	KS		
12	24	8	16	38	9	12	12	13	17	M4	-	on request
20	36	13	30	58	13	20	20	22	31	M6	0.115	R02-14 *
30	52	20	40	84	20	30	30	32	41	M8	0.275	R03-14 *
40	62	25	50	104	25	40	40	42	51	M8	0.440	R04-14 *
50	72	30	60	124	30	50	50	52	61	M8	0.670	R05-14 *

\* on request

For diameter D / D1 tolerances, see page 120

### Horizontal Support

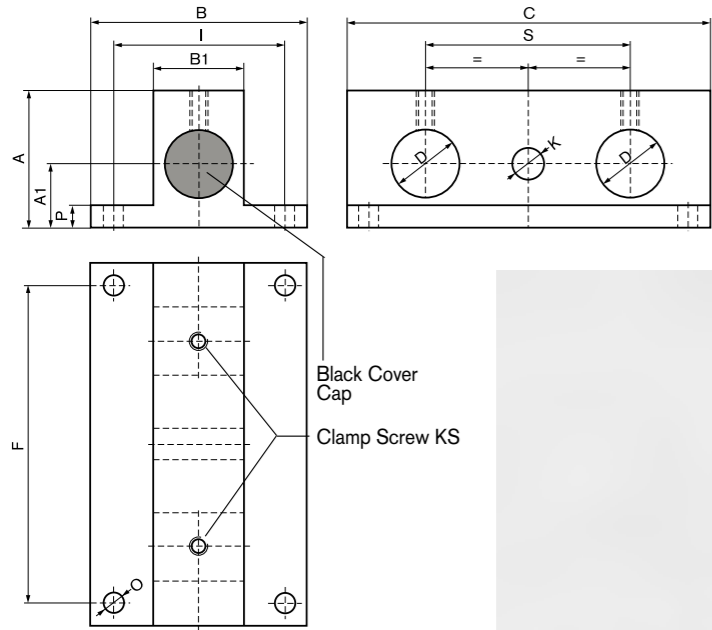

**Use**  
The Horizontal Support is usually needed to close off adjustable units. However, it can also be used independently as a static or dynamic clamp.

Nominal Diameter	Dimensions												Weight		Order Number
	A	A1	B	B1	C	D	F	I	K	O	P	S	KS	in kg	
20	45	22	65	30	110	20	95	50	10	7	8	60	M6	0.360	R02-90
30	60	28	95	40	160	30	140	75	14	9	8	90	M8	0.845	R03-90
40	72	35	95	50	200	40	180	75	14	9	10	120	M8	1.390	R04-90

Other combinations on request; for diameter D tolerances, see page [120](#)

### Vertical Clamp

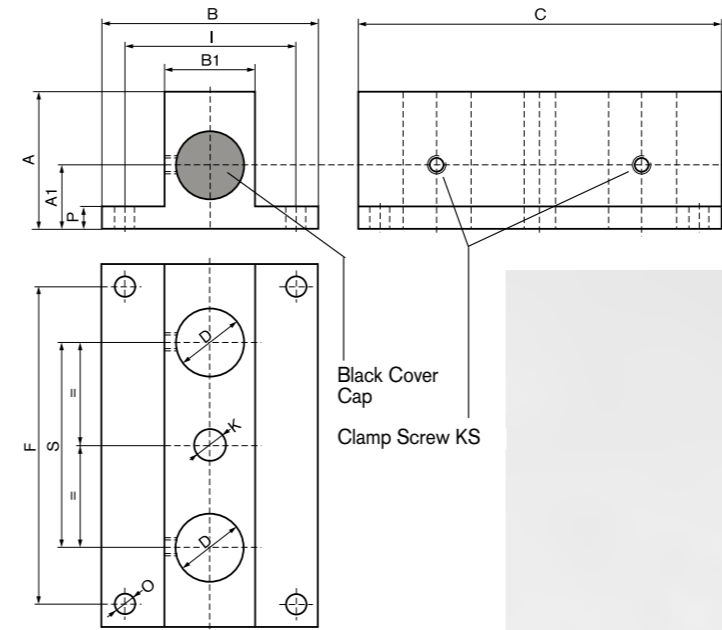

**Use**  
The same uses as the Horizontal Support. It can also be used as a carrier for handling equipment which needs to be rearranged simply and quickly.

Nominal Diameter	Dimensions												Weight		Order Number
	A	A1	B	B1	C	D	F	I	K	O	P	S	KS	in kg	
20	45	22	65	30	110	20	95	50	10	7	8	60	M6	0.330	R02-91
30	60	28	95	40	160	30	140	75	14	9	8	90	M6	0.760	R03-91
40	72	35	95	50	200	40	180	75	14	9	10	120	M6	1.225	R04-91

Other combinations on request; for diameter D tolerances, see page [120](#)

### Universal Support

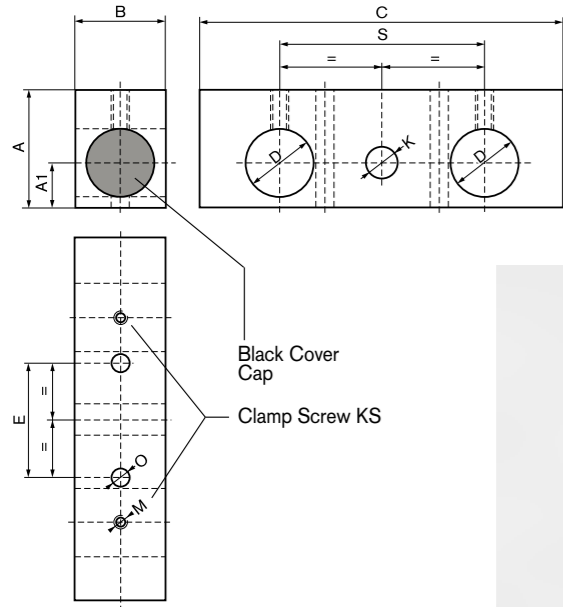

**Application**

Same use as the horizontal and vertical support but with the advantage that this component can be used as horizontal and vertical adjustable unit.

Nominal Diameter	Dimensions										Weight in kg	Order Number
	A	A1	B	C	D	E	O	K	S	KS		
20	36	13	30	110	20	25	6.5	10	60	M6	0.190	R02-30
30	52	20	40	160	30	50	8.5	14	90	M8	0.520	R03-30
40	62	25	50	200	40	50	8.5	14	120	M8	0.870	R04-30

Other combinations on request; for diameter D tolerances, see page 120

### Universal Slides

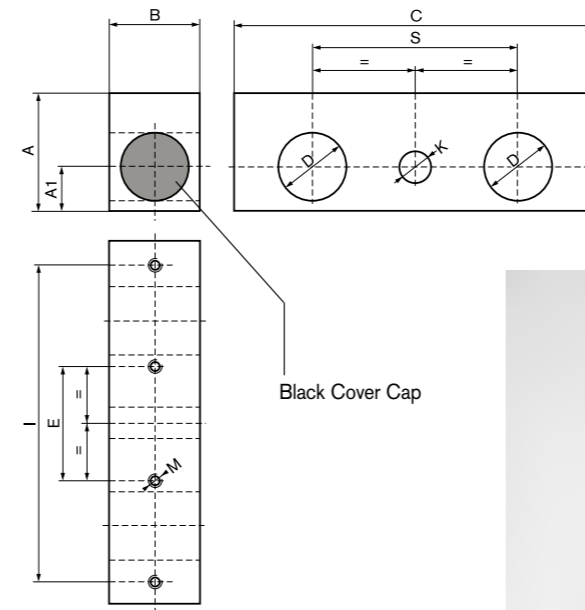

Illustration with clamp and sliding bush



Illustration without clamp

**Application**

Simple adjustable units can be built in modular form, in combination with various supports. The four threads are used to fix other structures in place.

Nominal Diameter	Dimensions										Weight in kg	Order Number single-sided clamp	Order Number double-sided clamp	Order Number without clamp
	A	A1	B	C	D	E	I	M	K	S				
20	36	13	30	110	20	25	95	M6	10	60	0.200	R02-31-GL	R02-32-GL	R02-41-GL
30	52	20	40	160	30	50	140	M8	14	90	0.535	R03-31-GL	R03-32-GL	R03-41-GL
40	62	25	50	200	40	50	180	M8	14	120	0.870	R04-31-GL	R04-32-GL	R04-41-GL

The slides are supplied with sliding bushes.

## Rectangular Extrusions

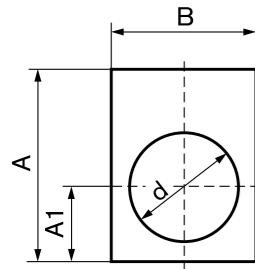

Can be supplied in warehouse length or cut to size.

Surface: untreated

## Flange Extrusions

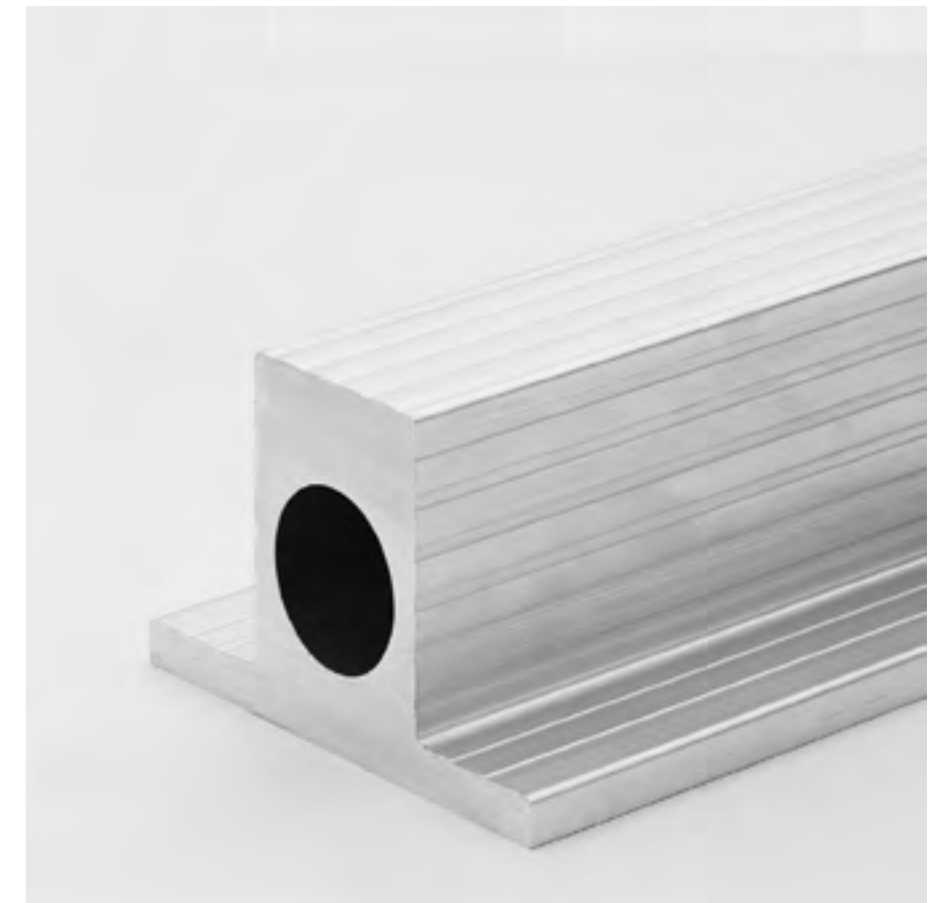
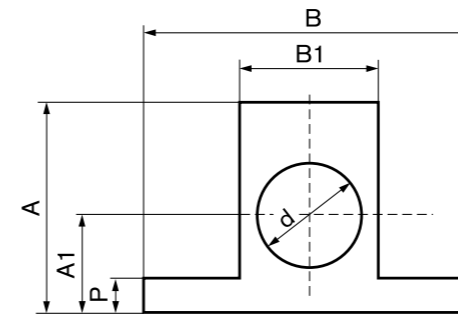

Can be supplied in warehouse length or cut to size.

Surface: untreated

Nominal Diameter	Dimensions				Weight kg/m	Order Number L = 3000 mm	Order Number cut to ... mm
	A	A1	B	d			
12	24	8	16	11,3	0.76	R01-95-3M	R01-95-02/ ... mm
20	36	13	30	19,2	2.10	R02-95-3M	R02-95-02/ ... mm
30	52	20	40	29,2	3.70	R03-95-3M	R03-95-02/ ... mm
40	62	25	50	39,2	4.96	R04-95-3M	R04-95-02/ ... mm
50	72	30	60	49,3	6.34	R05-95-3M	R05-95-02/ ... mm

Nominal Diameter	Dimensions						Weight kg/m	Order Number L = 3000 mm	Order Number cut to ... mm
	A	A1	B	B1	d	P			
12	28	12	35	16	11,0	4	1.11	R01-96-3M	R01-96-02/ ... mm
0	45	-	65	30	-	8	4.35	R15-94-3M	R15-94-02/ ... mm
20	45	22	65	30	19.0	8	3.63	R02-96-3M	R02-96-02/ ... mm
30	60	28	95	40	27.0	8	5.88	R03-96-3M	R03-96-02/ ... mm
40	72	35	95	50	39.0	10	7.63	R04-96-3M	R04-96-02/ ... mm
50	82	40	120	60	49.0	10	9.71	R05-96-3M	R05-96-02/ ... mm

## Aluminium Tubes

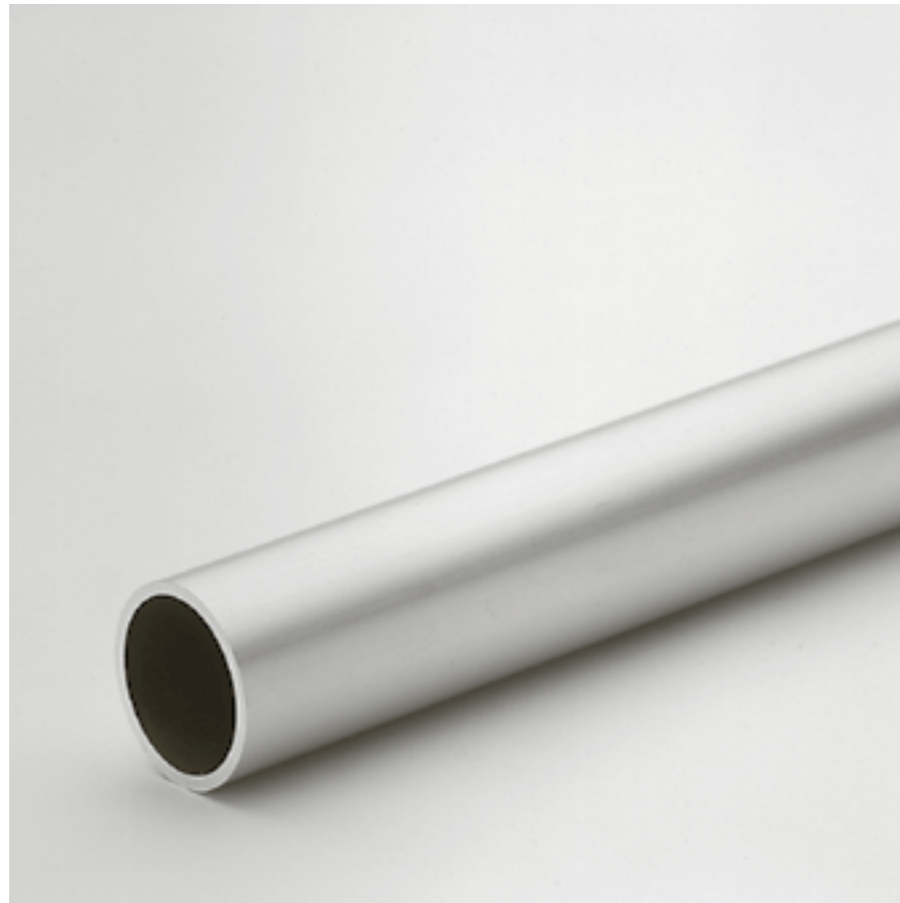
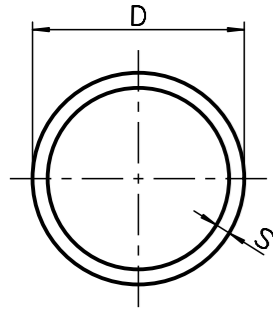

Can be supplied in warehouse length or cut to size.

Surface: untreated

Nominal Diameter	Dimension D1 x S	Weight kg/m	Order Number L = 5000 mm	Order Number cut to ... mm
12	12 x 1.5	0.130	R01-97-5M	R01-97-02/ ... mm
20	20 x 2	0.310	R02-97-5M	R02-97-02/ ... mm
30	30 x 2	0.480	R03-97-5M	R03-97-02/ ... mm
40	40 x 2	0.650	R04-97-5M	R04-97-02/ ... mm
50	50 x 3	1.210	R05-97-5M	R05-97-02/ ... mm

For diameter D tolerances, see page [120](#)

## Threaded Inserts

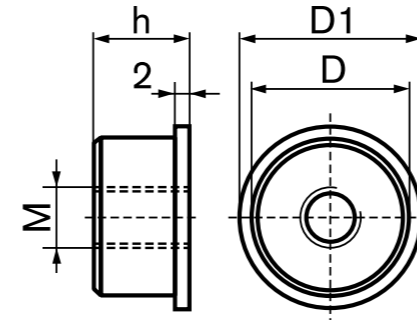

For aluminium tubes.

Material: aluminium

Nominal diameter	Dimensions			M	Order Number
	D	D1	h		
20	16	20	15	M10	R14-20
30	26	30	15	M10	R14-30
40	36	40	20	M16	R14-40
50	44	50	20	M16	R14-50



## Levelling feet

### Application

Variable height adjustment and level compensation.

### Specification

Cup: PA-GF black  
Bolt/locknut: 8.8 steel, zinc-coated



Material	Levelling flange diameter	Dimension: Thread M x L	Load capacity F	Order number with 3 x Ø9	Order number without 3 x Ø9
PA-GF	50	10 x 50	2500 N		B 42-50
	50	10 x 100	2500 N		B 42-00
	50	16 x 50	3500 N		B 44-50
	50	16 x 100	3500 N		B 44-00
	90	16 x 50	5000 N		B 45-50
	90	16 x 100	5000 N		B 45-00
Aluminium	90	16 x 50	10000 N	B 45-51	B 45-52 (-D)*
	90	16 x 100	10000 N	B 45-01	B 45-02 (-D)*

\* These versions are also available with damping components: add -D to the order number.

## Wheels

### Application

Universally applicable, everywhere where mobility is required.

### Specification

Shackle: Galvanized steel, ball bearing  
Wheel: Rubber running wheel, ball bearing



Wheel	Ø	wide	high	Thread dia. / M x L	Order number without brake	Order number with brake
Wheels	50	18	70	Ø 10,3	B 48-50	B 49-50
Wheels	75	25	97	Ø 10,3	B 48-75	B 49-75
Wheels	100	32	132	Ø 10,3	B 48-100	B 49-100
Wheels	100	32	132	M 16 x 25	A 48-100	A 49-100
Wheels	125	32	158	Ø 10,3	B 48-125	B 49-125
Wheels	125	32	158	M 16 x 25	A 48-125	A 49-125

Other dimensions and conductive wheels can be supplied on request.

The complete range with more information can be found on page 88.

## Plastic Caps

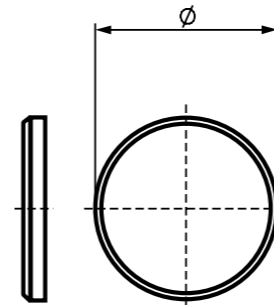

For Tube Clamps

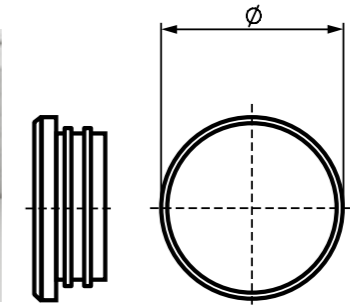

For Aluminium Tubes

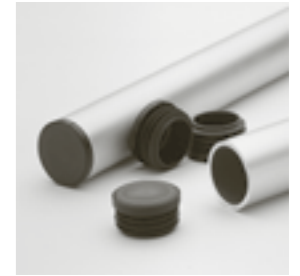

Nominal diameter	Order Number
20	R10-20
30	R10-30
40	R10-40
50	R10-50

The tube clamp units are generally supplied with plastic caps.

Nominal diameter	Order Number
20	R11-20
30	R11-30
40	R11-40
50	R11-50

## Clamp Lever

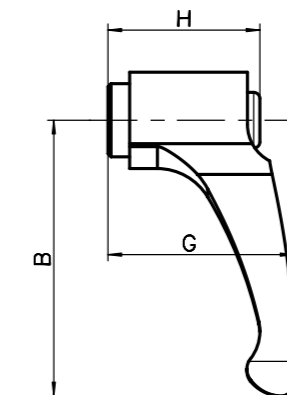
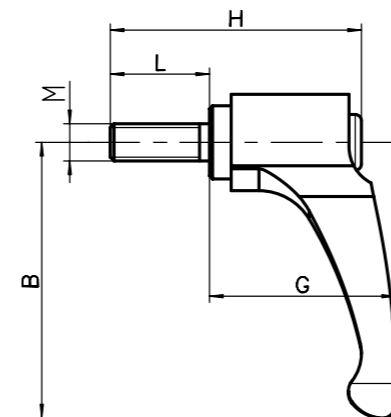

All tube clamp elements can also be supplied with clamp levers:

Add ...-K or ...-2K to the order number.



Nominal Thread M	Dimensions: B	G	H	L	Order Number
M6	45	29	25	-	R65-60
M6	45	29	25	16	R65-62
M6	45	29	25	32	R65-63
M8	63.5	38	31	-	R65-80
M8	63.5	43.5	38.5	20	R65-82*
M8	63.5	38	31	40	R65-84
M8	63.5	38	47	16	R65-81

\*Lever: plastic

## Adjustable Units

The Kanya Adjustable Units have been specifically developed with low cost in mind. The modular kit principle means that joints can be assembled at reasonable prices. The customer is free to choose according to his requirements – the Adjustable Unit still remains a standard item. The selection includes three sizes with different adjustment ranges. The spindle end is manufactured according to your specifications, or is fitted with a handwheel.

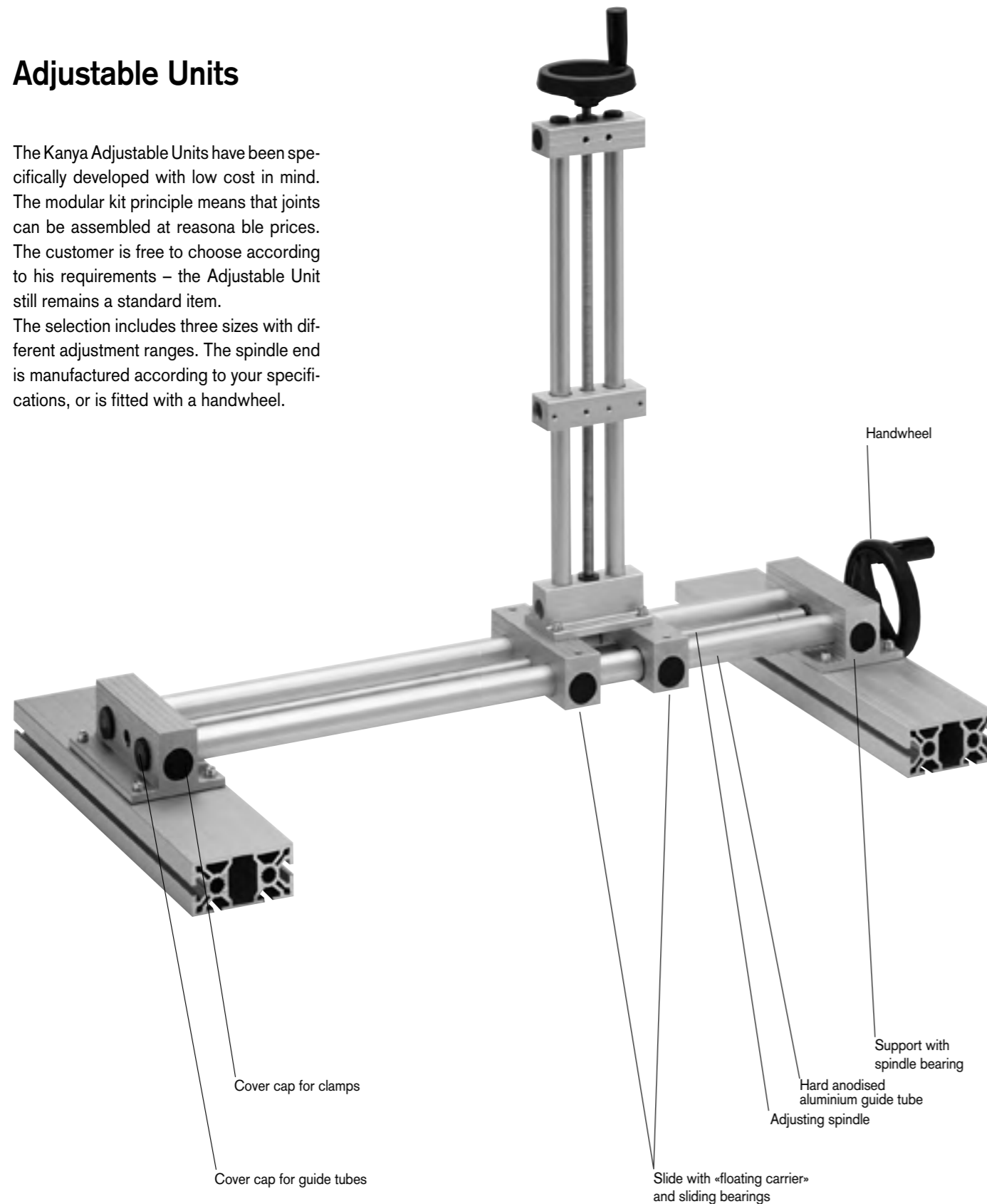

## Ordering Information

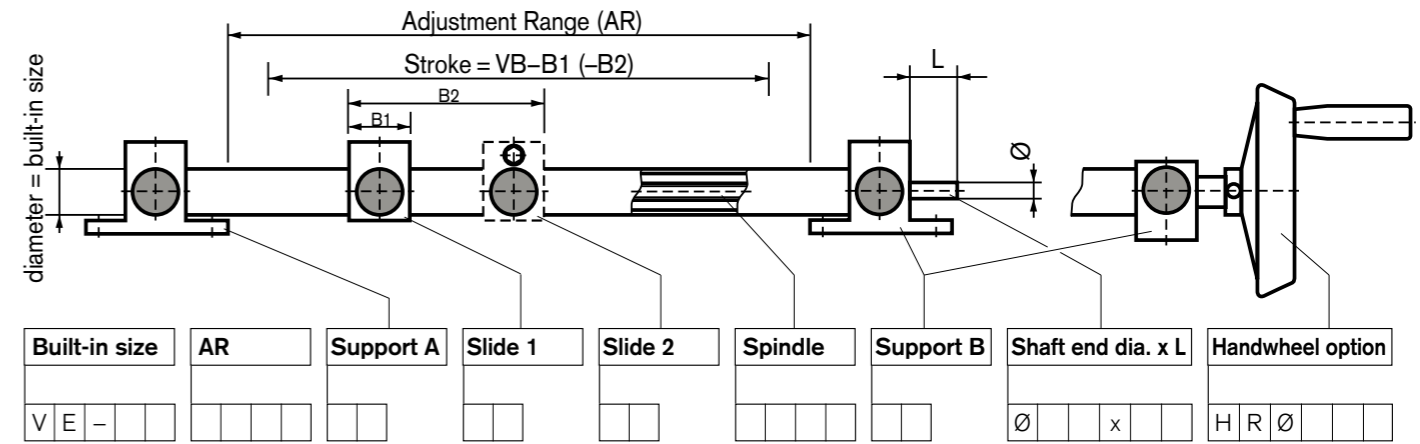

### Examples:

VE - 20	1250	90	31	-	M 12	90	Ø 10 x 20	
VE - 40	2300	91	31	41	TR 16	30		HR Ø 160

Warehouse items	Stroke	Support A/B	Slide 1/2	Spindle	Shaft end	Handwheel
VE20	-1500	R02-90 / -91 / -30	R02-31-GL / -41-GL	M12 x 1.75 / TR 12 x 3	as indicated	HR - Ø 80 / Ø 100
VE30	-2000	R03-90 / -91 / -30	R03-31-GL / -41-GL	M16 x 2.0 / TR 16 x 4	as indicated	HR - Ø 125
VE40	-2500	R04-90 / -91 / -30	R04-31-GL / -41-GL	M20 x 2.5 / TR 20 x 4	as indicated	HR - Ø 160 / Ø 200

See pages 221 – 224 for measurement information on the Supports and Slides

Other diameter and inclinations on request

Kanya supplies the Adjustable Units fully assembled. Please enquire about additional items which we are able to supply.

### Note Adjustable Units:

VE20 up to	900 mm
VE30 up to	1200 mm
VE40 up to	1500 mm

## Adjustable Units

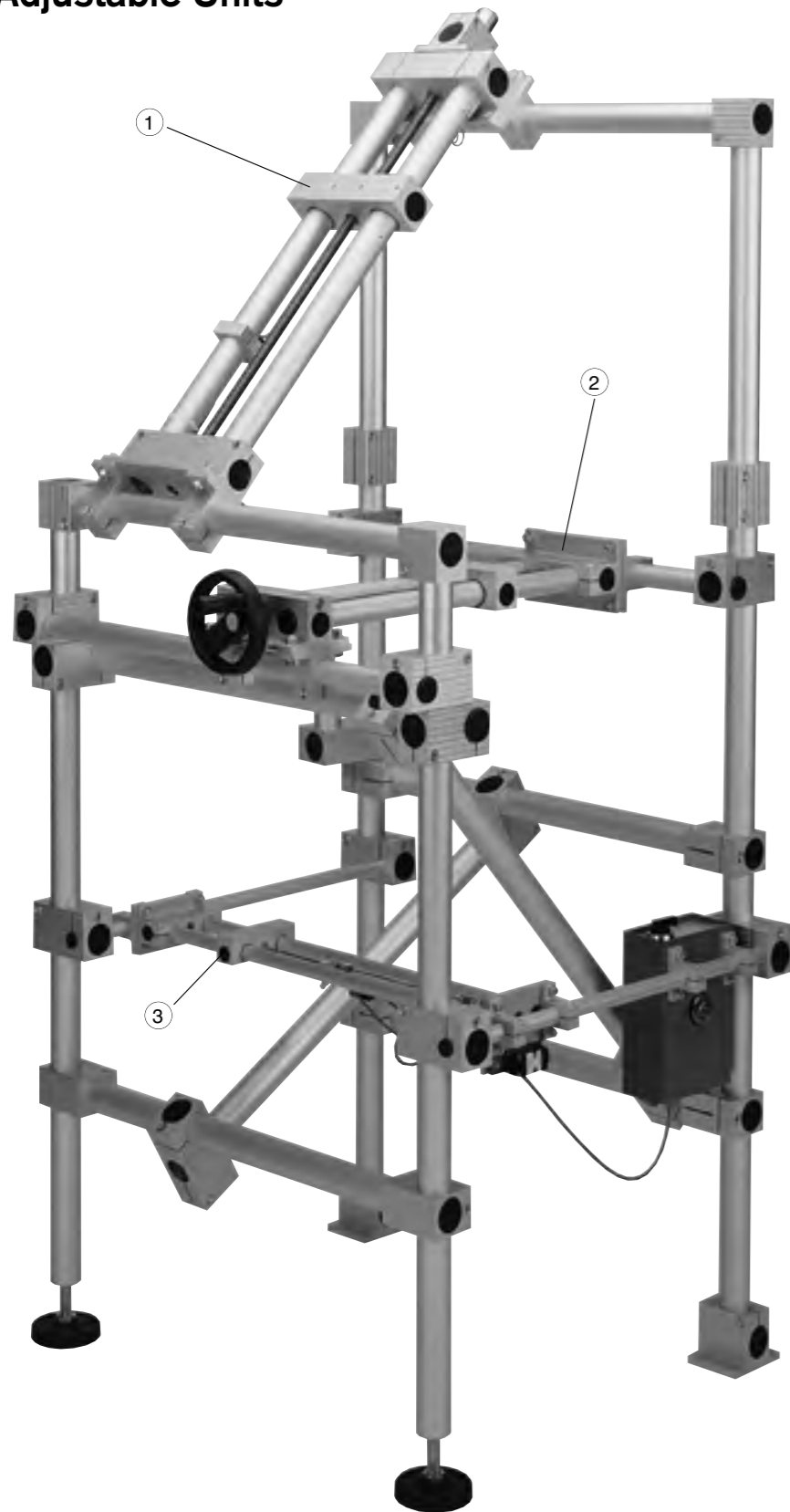

### Use

Simple adjustment mechanisms with average precision and normal phase times. This adjustable unit is robust and reliable, and can be used wherever costs need to be kept down or wherever cost-effectiveness is the decisive factor.

Mechanical engineering, automation, laboratories, photographic studios, table adjustments, etc.

### Versions

- ① with metric threaded spindle
- ② with trapezoidal threaded spindle and handwheel
- ③ with pneumatic cylinder

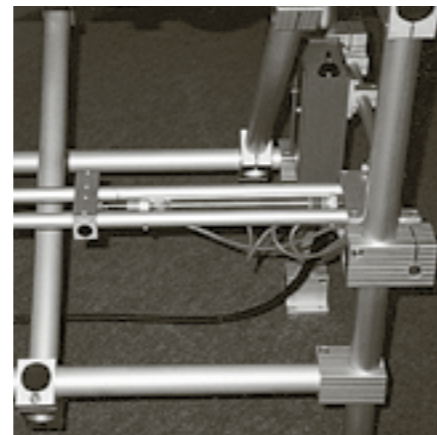

...or to your specifications.

**Service**

## Our service



**CAD Download**  
Over 60 different formats



**Consulting**  
Personal & competent



**Distribution worldwide**  
Over 20 long-standing partners

[www.kanya.com](http://www.kanya.com)

Follow us on:



## Index

Term	Page	Term	Page	Term	Page	Term	Page	Term	Page	Term	Page
20 mm base extrusion	<a href="#">59–60</a>	Clamping block	<a href="#">69</a>	<b>F</b>		<b>L</b>		<b>R</b>		Support extrusion	<a href="#">66</a>
30 mm base extrusion	<a href="#">53–58</a>	Clamping block base 50/40/30	<a href="#">81</a>	Filler strips	<a href="#">97–98</a>	Leg bolt-down socket	<a href="#">88</a>	Recessed grip	<a href="#">106</a>	Supporting extrusion	<a href="#">98</a>
40 mm base extrusion	<a href="#">44–52</a>	Clamping block	<a href="#">81</a>	Flange extrusions	<a href="#">127</a>	Levelling feet	<a href="#">85–86/129</a>	Rectangular extrusion	<a href="#">127</a>	Suspended guard fittings	<a href="#">101</a>
45 mm base extrusion	<a href="#">37–43</a>	Clamping nuts	<a href="#">83</a>	Flat sealing element	<a href="#">110</a>	Linear sliding block	<a href="#">111</a>	Rectangular tube	<a href="#">69</a>	Suspension extrusion	<a href="#">65</a>
50 mm base extrusion	<a href="#">28–36</a>	Clamping rubber seal	<a href="#">101</a>	Floor bolting bracket	<a href="#">86</a>	Lug	<a href="#">108</a>	Retaining clips	<a href="#">91</a>		
		Clamping sealing strip	<a href="#">101</a>	Foot plates	<a href="#">86</a>			Ribbed rubber extrusion	<a href="#">100</a>	<b>T</b>	
<b>A</b>		Composite panels	<a href="#">94</a>	Frame extrusion	<a href="#">64</a>			Rod lock	<a href="#">109</a>	T clamp	<a href="#">121</a>
Acrylic glass	<a href="#">94</a>	Concave double-wheeled trolley	<a href="#">90</a>	Front cover	<a href="#">93</a>	<b>M</b>		Roller cover cpl.	<a href="#">115</a>	T-bolts	<a href="#">82</a>
Adjustable units	<a href="#">130–131</a>	Concave roller	<a href="#">89</a>			Machining codes	<a href="#">24–26</a>	Roller holder	<a href="#">118</a>	Threaded inserts	<a href="#">84/128</a>
Allen key	<a href="#">78</a>	Connectors	<a href="#">71–75</a>	<b>G</b>		Magnet nuts	<a href="#">83</a>	Roller stopper	<a href="#">119</a>	Threaded plates	<a href="#">82</a>
Aluminium sealing extrusion	<a href="#">97</a>	Corner pieces	<a href="#">105</a>	Grease scraper	<a href="#">114</a>	Magnetic fasteners	<a href="#">107</a>	Roller system	<a href="#">117</a>	Tie wrap	<a href="#">92</a>
Aluminium sheets	<a href="#">95</a>	Counterweight extrusion	<a href="#">70</a>	Grease scraper support	<a href="#">114</a>	Micro chipboard	<a href="#">94</a>	Roller track adapter	<a href="#">118</a>	Triple channel extrusion 30x15	<a href="#">62</a>
Angle clamp	<a href="#">121</a>	Covering cap for front cover	<a href="#">93</a>	Grid extrusion	<a href="#">100</a>	Mounting bracket and dowel	<a href="#">81</a>	Roller tracks flat	<a href="#">117</a>	T-swivel clamps	<a href="#">124</a>
Angle extrusion	<a href="#">67–68</a>	Covering cap for PVS®-connector	<a href="#">75</a>	Ground anchoring bracket	<a href="#">87</a>	Mounting bracket ball catch	<a href="#">107</a>	Roller tracks with guide flange	<a href="#">118</a>	Tube handle offset	<a href="#">106</a>
Anti-return	<a href="#">119</a>	Cross-cable tie block	<a href="#">92</a>	Guide extrusion	<a href="#">66</a>	Mounting brackets	<a href="#">80/107</a>	Rollers	<a href="#">89/114</a>	Tube handle straight	<a href="#">106</a>
Anti-twist spigots	<a href="#">85</a>	Cross clamp	<a href="#">121</a>	Gusset plate	<a href="#">86</a>			Runner extrusion	<a href="#">64</a>	Tubes	<a href="#">128</a>
Arrester plate	<a href="#">108</a>	Cross clamp with different Ø	<a href="#">122</a>			<b>N</b>				Tubes cleat	<a href="#">123</a>
Attachment bracket	<a href="#">82</a>	Cross swivel clamp	<a href="#">124</a>	<b>H</b>		Non-swivel castors	<a href="#">88</a>	<b>S</b>			
Auxiliary extrusion	<a href="#">63</a>	Cross T-clamp	<a href="#">122</a>	H-strip	<a href="#">98</a>			Safety-edge extrusion	<a href="#">99</a>	<b>U</b>	
				Half-round threaded plates	<a href="#">82</a>	<b>O</b>		Safety switches	<a href="#">109</a>	U-clamping extrusion	<a href="#">65</a>
<b>B</b>		<b>D</b>		Hammer nuts	<a href="#">83</a>	Octagonal extrusion	<a href="#">64</a>	Sealing plates	<a href="#">110</a>	U-sealing strip	<a href="#">100</a>
Ball catches	<a href="#">107</a>	Door stop profile	<a href="#">99</a>	Handle strip	<a href="#">108</a>			Self-cutting threaded inserts	<a href="#">85</a>	Uniblocks	<a href="#">81</a>
Base plates	<a href="#">86</a>	Double bolting bracket	<a href="#">87</a>	Handle strip extrusion	<a href="#">69</a>	<b>P</b>		Semi-circular sealing strip	<a href="#">100</a>	Universal clamp	<a href="#">122</a>
Box frame extrusion	<a href="#">64</a>	Double clamping extrusion	<a href="#">65</a>	Handles	<a href="#">105</a>	Panel clamp extrusion	<a href="#">65</a>	Shaft clamping blocks	<a href="#">110</a>	Universal slides	<a href="#">126</a>
Bracket	<a href="#">80</a>	Double extrusion nuts	<a href="#">83</a>	Hinge extrusion	<a href="#">68</a>	Parallel clamp	<a href="#">121</a>	Shaft clamping extrusions	<a href="#">112</a>	Universal support	<a href="#">126</a>
Buffer	<a href="#">115</a>	Double threaded plates	<a href="#">82</a>	Hinges	<a href="#">102–103</a>	Perforated sheets	<a href="#">95</a>	Shaft clamping extrusions 2-part	<a href="#">113</a>		
		Double-wheeled trolley	<a href="#">90</a>	Horizontal clamp	<a href="#">123</a>	PET-G	<a href="#">95</a>	Shaft support extrusion	<a href="#">111</a>	<b>V</b>	
<b>C</b>				Horizontal support	<a href="#">125</a>	Polycarbonate	<a href="#">94</a>	Single bolting bracket	<a href="#">87</a>	«Velcro» cable ties	<a href="#">92</a>
C-guide rails	<a href="#">116</a>	<b>E</b>				Protective edge profile	<a href="#">99</a>	Single bolting bracket, reinforced	<a href="#">87</a>	Vertical clamp	<a href="#">123/125</a>
Cable bridge	<a href="#">78</a>	End caps	<a href="#">84</a>	<b>I</b>		PVC foam plates	<a href="#">95</a>	Slide extrusion	<a href="#">90–91</a>		
Cable ducts	<a href="#">91–93</a>	End stop	<a href="#">115</a>	Inlay profile	<a href="#">100</a>	PVS® direct connectors	<a href="#">77</a>	Slide plates	<a href="#">112/113</a>	<b>W</b>	
Caps	<a href="#">129</a>	End swivel clamp	<a href="#">124</a>	Insert extrusion	<a href="#">97</a>	PVS® screw «Safe»	<a href="#">75</a>	Slides	<a href="#">116</a>	Wall rail 18x50	<a href="#">61</a>
Castors	<a href="#">88–89</a>	Expanded metal	<a href="#">95</a>	Inset lock	<a href="#">109</a>	PVS® superlight	<a href="#">77</a>	Sliding hook	<a href="#">91</a>	Wedge extrusion	<a href="#">98</a>
Channel reducing strips	<a href="#">95/98</a>	Expanding sleeve	<a href="#">85</a>	<b>J</b>				Slot extrusion	<a href="#">61</a>	Wheels	<a href="#">129</a>
Clamp ring	<a href="#">120</a>	Extrusion nuts	<a href="#">83</a>	Joining clamp	<a href="#">120</a>	<b>Q</b>		Snap-lock	<a href="#">109</a>		
Clamp lever	<a href="#">129</a>			Joint base	<a href="#">104</a>	Quick-release fasteners	<a href="#">108</a>	Spacer for roller shield	<a href="#">114</a>		
								Steel shafts	<a href="#">110</a>		
								Steel wire mesh	<a href="#">96</a>		



### Headquater

Kanya AG  
 Neuhofstrasse 9  
 8630 Rüti  
 Schweiz  
 T +41 (0)55 251 58 58  
 F +41 (0)55 251 58 68  
[info@kanya.com](mailto:info@kanya.com)  
[www.kanya.com](http://www.kanya.com)

### Branch office

Bachtel China Ltd.  
 32 Hongxi Road, Suzhou  
 Jiangsu 215151  
 China  
 T +86 (0) 512 65360065  
 F +86 (0) 512 65360906  
[info@bachtelgroup.com.cn](mailto:info@bachtelgroup.com.cn)  
[www.kanya.com/cn](http://www.kanya.com/cn)

### Representatives

- A** Ventor Sicherheitssysteme und Automatisierung  
[verkauf@ventor.at](mailto:verkauf@ventor.at)  
[www.ventor.at](http://www.ventor.at)
- BR** ABG Indústria e Comércio Ltda.  
[info@abg.ind.br](mailto:info@abg.ind.br)  
[www.abg.ind.br](http://www.abg.ind.br)
- CZ/SK** WT WINTECH a.s.  
[alu@wintech.cz](mailto:alu@wintech.cz)  
[www.wintech.cz/alu](http://www.wintech.cz/alu)
- D** August Dreckshage GmbH & Co. KG  
 PLZ 1, 2, 3, 4, 5  
[info@dreckshage.de](mailto:info@dreckshage.de)  
[www.dreckshage.de](http://www.dreckshage.de)
- D** KANYA Deutschland GmbH  
 PLZ 0, 35, 54–56, 6, 7, 8, 9  
[info@kanya-deutschland.de](mailto:info@kanya-deutschland.de)  
[www.kanya-deutschland.de](http://www.kanya-deutschland.de)
- DK** JJ Mechatronic A/S  
[info@jjas.dk](mailto:info@jjas.dk)  
[www.jjas.dk](http://www.jjas.dk)
- F** Bernay Automation SA  
[info@bernay-automation.com](mailto:info@bernay-automation.com)  
[www.bernay-automation.com](http://www.bernay-automation.com)
- UK/IE** Kanya UK  
[info@kanya-uk.co.uk](mailto:info@kanya-uk.co.uk)  
[www.kanya-uk.co.uk](http://www.kanya-uk.co.uk)
- I** Meccania S.R.L.  
[info@meccania.com](mailto:info@meccania.com)  
[www.meccania.com](http://www.meccania.com)
- IL** Conlog LTD  
[conlog@conlog.co.il](mailto:conlog@conlog.co.il)  
[www.conlog.co.il](http://www.conlog.co.il)
- J** MIWA CO. LTD  
[postmiwa@miwa-inc.co.jp](mailto:postmiwa@miwa-inc.co.jp)  
[www.miwa-inc.co.jp](http://www.miwa-inc.co.jp)
- NL** TEVEL Techniek bv  
[info@tevel.nl](mailto:info@tevel.nl)  
[www.tevel.nl](http://www.tevel.nl)
- PL** TABAL Sp. J.  
[kanya@tabal.pl](mailto:kanya@tabal.pl)  
[www.tabal.pl](http://www.tabal.pl)
- PL** JORDAN matcon Sp. z o.o.  
[profile@jordan-matcon.pl](mailto:profile@jordan-matcon.pl)  
[www.jordan-matcon.pl](http://www.jordan-matcon.pl)
- RC** Bachtel China Ltd.  
[info@bachtelgroup.com.cn](mailto:info@bachtelgroup.com.cn)  
[www.kanya.com/cn](http://www.kanya.com/cn)
- RC** Chongqing Holje Precision Machinery Co. Ltd  
[www.holje.cn](http://www.holje.cn)
- RO** ARDACO TEHNIC METAL  
[office@ardacometal.ro](mailto:office@ardacometal.ro)  
[www.ardacometal.ro](http://www.ardacometal.ro)
- RU** Servotechnica  
[info@servotechnica.ru](mailto:info@servotechnica.ru)  
[www.servotechnica.ru](http://www.servotechnica.ru)
- S** EIE Maskin AB  
[info@eiemaskin.se](mailto:info@eiemaskin.se)  
[www.eiemaskin.se](http://www.eiemaskin.se)
- TN** HR-Engineering Sarl  
[info@hrengineering-tn.com](mailto:info@hrengineering-tn.com)  
[www.hrengineering-tn.com](http://www.hrengineering-tn.com)
- USA** A-Line Corporation  
[sales@aline1.com](mailto:sales@aline1.com)  
[www.aline1.com](http://www.aline1.com)

### Internationally registered trademarks:



### Certificate of Approval:

**ISO 9001**

### Indications

#### Patent

This catalogue contains products that are subject to international patent rights. Any imitation of such products constitutes a violation of the law and involves compensation for damages.

#### Product liability

Kanya's product liability is subject to Swiss substantive law only. Kanya is not liable for any further claims and in particular denies liability for copied products or own application of our products by the user.

May only reproduced in whole or in part with the permission of Kanya AG, Switzerland. The right to make technical modifications is reserved.

© by Kanya AG [06/2023 – Online catalog]

